

Replacement Parts

Replacement parts are listed on the following pages. To order parts or reach our service department, call 1-800-274-6848, Monday through Friday (see our website for business hours, www.powermatic.com). Having the Model Number and Serial Number of your machine available when you call will allow us to serve you quickly and accurately.

Parts List: Base Assembly (60C and 60HH)

Index No.	Part No.	Description	Size	Qty
1	6296000	Rear Table		1
2	TS-0267041	Set Screw	1/4"-20x3/8"	6
3	6296001	Collar		1
4	6296002	Bracket		1
5	6296003	Key	5x5x12mm	1
6	6296004	Lead Screw		1
7	6296005	Bracket		1
8	TS-0720091	Lock Washer	3/8"	2
9	TS-0209061	Cap Screw	3/8"-16x1-1/4"	2
10	TS-0720111	Lock Washer	1/2"	2
11	6296009	Cap Screw	1/2"-12NCx1-1/2"	2
12	6296010	Bolt		2
13	TS-0561021	Hex Nut	5/16"-18	9
14	TS-0267091	Set Screw	1/4"-20x1"	6
15	60B-215	Base		1
16	6296013	Gib		2
17	TS-0208041	Socket Head Cap Screw	5/16"-18x3/4"	3
18	6296015	Retaining Ring	ETW-6	3
19	6296132	Bar		1
20	6296016	Bolt		1
21	6296017	Shaft		1
22	6296018	Lock Bracket		1
23	6296019	Bracket		1
24	6296020	Ball		2
25	6296021	Shaft		1
26	6296022	Retaining Ring	ETW-12	2
27	6296023	Worm		1
28	6296024	Key	5x5x20	1
29	6296025	Adjusting Base		1
30	TS-0680021	Flat Washer	1/4"	1
31	TS-0050031	Hex Cap Screw	1/4"-20x3/4"	1
32	6296029	Worm Shaft		1
33	6296028	Handle		1
34	TS-0680021	Flat Washer	1/4"	2
35	TS-0207021	Socket Head Cap Screw	1/4"-20x1/2"	6
36	TS-0720071	Lock Washer	1/4"	5
37	6296033	Clamp Knob		1
38	TS-0680061	Flat Washer	1/2"	1
39	6296035	Lock Plate		1
40	6296036	Plate		1
41	60B-241	Front Table		1
42	6296038	Handwheel		1
43	6296039	Phillips Pan Head Screw	5/16"-18x1/2"	1
44	TS-0680041	Flat Washer	3/8"	1
45	60B-245	Rabbeting Ledge		1
46	TS-0680041	Flat Washer		3
47	TS-0060051	Hex Cap Screw	3/8"-16x1"	2
48	6296044	Pointer		1

49	TS-081B012	Phillips Pan Head Screw	#8-32x1/4"	1
50	6296056	Bolt		1
51	6296057	Belt Guard		1
52	6296058	Knob		1
53	TS-0270091	Set Screw	5/16"-18x1"	2
54	6296061	Set Block		1
55	6296062	Bolt		1
56	6296063	Collar		1
57	TS-0680031	Flat Washer	5/16"	6
59	6296167	Depth Scale		1
60	VS020500	Rivet	2x5mm	4
61	TS-0267021	Socket Set Screw	1/4"-20x1/4"	4
62	6296151	Collar		2
63	60C-263	Push Block		2
64	TS-0208021	Socket Head Cap Screw	5/16"-18x1/2"	1
65	6296166	Flat Washer	5/16"x3/4"D	2
66	TS-0209071	Socket Head Cap Screw	3/8"-16x1-1/2"	2
67	TS-1550071	Flat Washer	3/8"x3/4"D	1
68	6296089	Key	9.5mmx273mm	1
69	6296088	Spring Pin	4x14mm	1
70	60C-270	Base Slide		1
71	60B-271	Stop Handle		1
	60B-270	Cutterhead Guard Assembly (Index # 72 thru 77)		1
72	60B-272	Warning Label		1
73	60B-273	Cutterhead Guard		1
74	JSG96-223	Retaining Ring	STW-11	1
75	60B-275	Spring		1
76	60B-276	Shaft		1
77	60B-277	Spring Pin	6x36mm	2
78	60C-278	I.D. Label	1Ph	1
	60C-278A	I.D. Label	3Ph	1
	60HH-278	I.D. Label	1Ph	1
	60HH-278A	I.D. Label	3Ph	1
79	TS-0207021	Socket Head Cap Screw	1/4"-20x1/4"	1

Parts List: Fence Assembly (60C and 60HH)

Index No.	Part No.	Description	Size	Qty
	PJ882-FA	Fence Assembly (Index #1 thru 49)		
1	PJ882-101	Hand Wheel		1
2	TS-0267021	Socket Set Screw	1/4"-20x1/4"	3
3	TS-0207031	Socket Head Cap Screw	1/4"-20x5/8"	4
4	PJ882-104	Bearing Cover		1
5	PJ882-105	C-Ring	STW-12	2
6	PJ882-106	Worm Shaft		1
7	BB-6001ZZ	Ball Bearing	6001ZZ	2
8	PJ882-108	Pin	Ø3x20mm	1
9	TS-0810012	Round Head Slotted Machine Screw	#10-24x1/4"	2
10	TS-0680011	Flat Washer	3/16"	2
11	PJ882-111	Pointer		1
12	6285945	Knob		1
13	6296069	Locking Shaft		1
14	6285944	Handle Stud		1
15	TS-0207021	Socket Head Cap Screw	1/4"-20x1/2"	1
16	6296084	Bolt		1
17	TS-0680061	Flat Washer	1/2"	1
18	PJ882-118	Nylon Nut	1/2"-12	1
19	PJ882-119	Locking Handle		1
20	PJ882-120	Bushing		1
21	PJ882-121	Stop Block		1
22	PJ882-122	Fence Bracket		1
23	PJ882-123	Worm		1
24	PJ882-124	Retaining Ring	RTW-28	1
25	TS-0050031	Hex Cap Screw	1/4"-20x3/4"	1
26	PJ882-126	Rack		1
27	PJ882-127	Locking Handle Nut		1
28	PJ882-128	Locking Link		1
29	TS-0561011	Hex Nut	1/4"-20	3
30	TS-0050051	Hex Cap Screw	1/4"-20x1"	2
31	PJ882-131	Safety Plate		1
32	TS-081F031	Phillips Flat Head Machine Screw	1/4"-20x1/2"	2
33	6296070	Pin	5mmx50mm	1
34	TS-0206021	Socket Head Cap Screw	#10-24x1/2"	5
35	6296073	Screw		1
36	6296082	Fence Link		1
37	6285942	Cone Point Screw		4
38	TS-0561031	Hex Nut	3/8"-16	4
39	TS-0720071	Lock Washer	1/4"	2
40	6285940	Pivot Stud		2
41	TS-0561052	Hex Nut	1/2"-20UNF	2
42	PJ882-142	Fixed Block		1
43	PJ882-143	Fence		1
44	PJ882-144	Insert		1
45	60B-130	Caution Label (Setting Knives)		1
46	60B-129	Caution Label (Hands Clear)		1
47	PJ882-147	Label (Lock/ Unlock)		1
48	PJ882-148	Scale Label		1
49	PJ882-333	Spring Pin	Ø4x25mm	1

Fence Assembly (60C and 60HH)

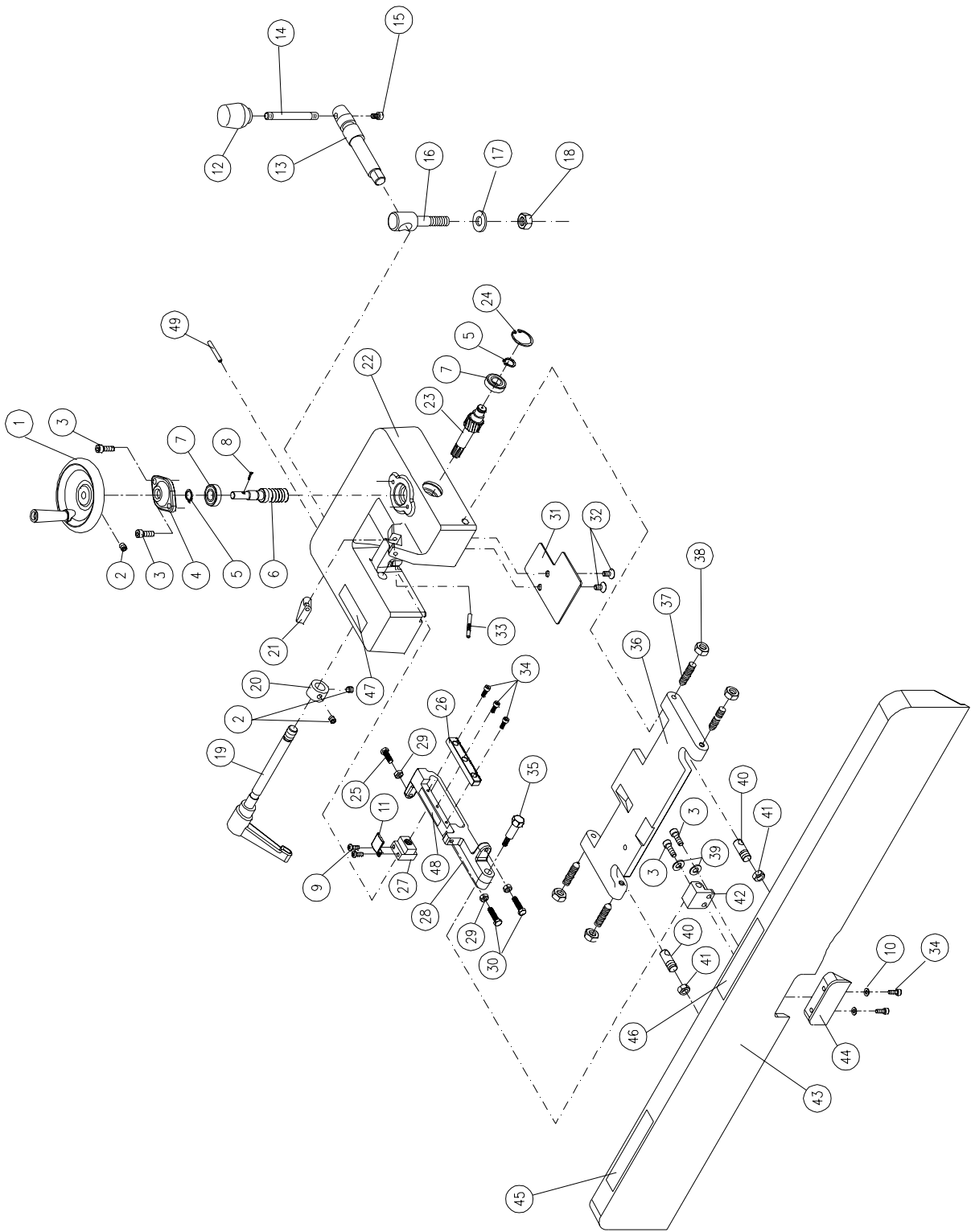

Parts List: Straight Cutterhead Assembly (60C only)

Index No.	Part No.	Description	Size	Qty
.....	60B-300	Cutterhead Assembly (Index # 1 thru 5, and 10 thru 13)		1
1.....	6296046	Knife		3
2.....	6296153	Knife Gib		3
3.....	6296048	Key	5x5x25mm	1
4.....	6296049	Ball Bearing	6203-2NSE	2
5.....	6296050	Bearing Housing		2
6.....	TS-0267021	Set Screw	1/4"-20x1/4"	2
7.....	6296051	Pulley		1
8.....	6285853	Bolt		2
9.....	TS-0720091	Lock Washer	3/8"	2
10.....	6296154	Square Head Screw		15
11.....	6296053	Cutterhead		1
12.....	6296054	Spring		6
13.....	6296055	Flat Head Screw	M5-0.8Px12	6
.....	60B-301	Knife Gauge Assembly (Index # 14, 15, 16)		1
14.....	6296155	Knife Gauge		2
15.....	6296156	Knife Gauge Bar		1
16.....	6296157	E-Clip	ETW-6	2

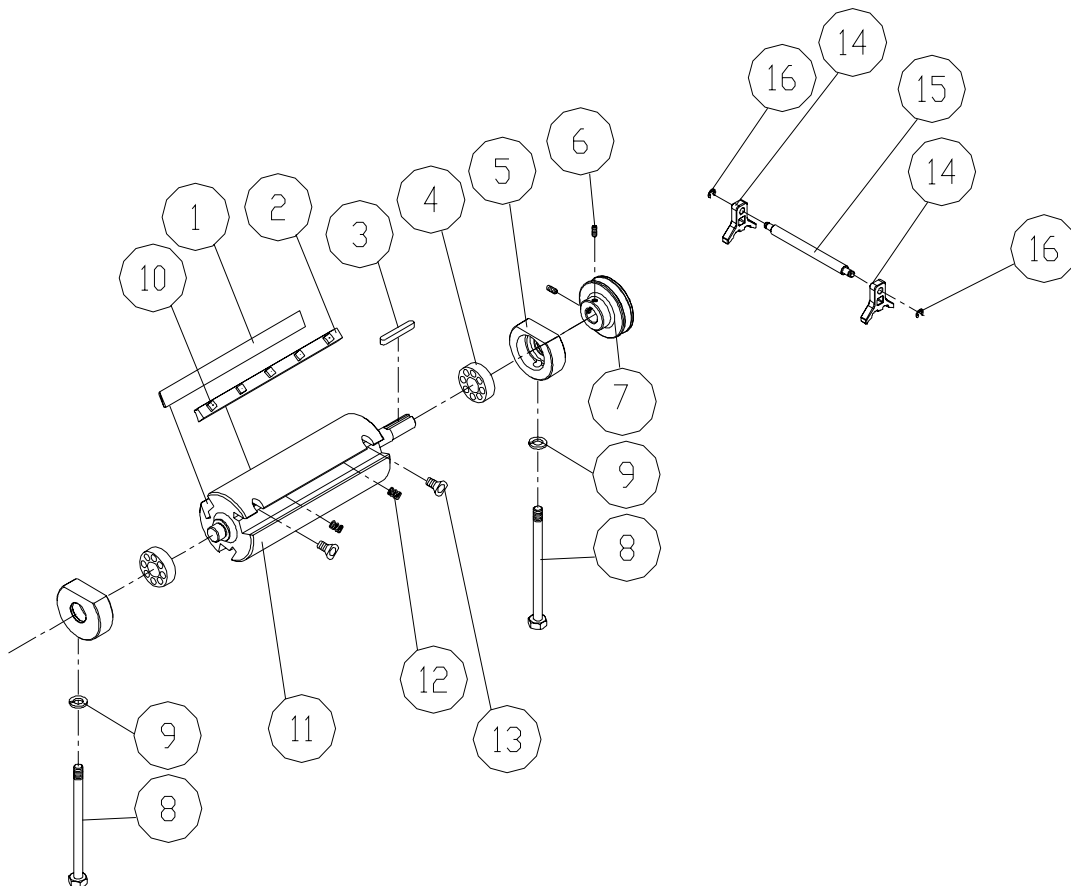

Parts List: Stand Assembly (60C and 60HH)

Index No.	Part No.	Description	Size	Qty
	2365025	60C/60HH Stand Assembly (Index #1 thru 51)	2HP, 1Ph, 230V	1
	2365026	60C/60HH Stand Assembly (Index #1 thru 51)	3HP, 3Ph, 230/460V	1
1	60C-401	Stand		1
2	60B-402	Door		1
3	60B-403	Carriage Bolt	3/8"-16x2-3/8"	3
4	TS-1550071	Flat Washer	3/8"	6
5	TS-1534042	Phillips Pan Head Machine Screw	M6x12	2
6	TS-1550041	Flat Washer	M6	2
7	6285975	Screw Knob		1
8	6285976	Door Lock		1
9	6285977	Hex Nut	3/8"-16	1
10	60B-410	Carriage Bolt	5/16"-18x3/4"	4
11	6285805	Flat Washer	5/16"	4
12	VB-A44	V-Belt	A-44	1
13	60B-413	Motor Pulley		1
14	TS-0267021	Set Screw	1/4"-20x1/4"	2
15	60B-415	Motor	2HP, 1Ph, 230V	1
	60B-415MF	Motor Fan (not shown)		1
	60B-415MFC	Motor Fan Cover (not shown)		1
	60B-415CS	Centrifugal Switch (not shown)		1
	60B-415MDC	Motor Dustproof Cover (not shown)		1
	60B-415CC	Capacitor Cover (not shown)		2
	60B-415SC	Starting Capacitor (not shown)	400MFD, 125VAC	1
	60B-415RC	Running Capacitor (not shown)	30uf, 350VAC	1
	60B-415A	Motor	3HP, 3Ph, 230/460V	1
16	6285988	Lock Washer	5/16"	4
17	6285966	Hex Nut	5/16"-18	1
18	60B-418	Motor Cord	1Ph	1
	60B-418A	Motor Cord	3Ph	1
19	PJ882-546	Control Switch		1
20	PM2000-298	Safety Key For Switch		1
21	60B-421	Power Cord	1PH	1
	60B-421A	Power Cord	3PH	1
22	60C-422	Switch Arm		1
23	6285909	Flat Washer	1/4"	4
24	6285910	Pan Head Screw	1/4"-20x1/2"	4
25	60B-425	Dust Chute		1
26	6285978	Key	5x5x30mm	1
27	60C-427	Cord Protector		1
28	PJ882-526	Magnetic Switch	1PH	1
	PJ882-526CS	Contactors Switch		1
	PJ882-526OR	Overload Relay		1
	60C-428A	Magnetic Switch	3PH	1
	60B-428ACSA	Contactors Switch		1
	60B-428AOR	Overload Relay		1
	60C-428AT	Transformer		1
	60B-428AF	Fuse		1
29	JWBS18-447	Screw	M5x8	5
30	TS-1550031	Flat Washer	M5	6
31	PJ882-551	Machine Screw	M5x50	2
32	PJ882-548	Switch Plate		1
33	TS-0732041	Star Washer	M5	2
34	TS-0208041	Socket Head Cap Screw	5/16"-18x3/4"	4
35	TS-0720081	Lock Washer	5/16"	4
36	TS-0680031	Flat Washer	5/16"	4
37	PM2000-105	Powermatic Nameplate		1
38	6296150	Warning Label		1

39	60C-439	Strain Relief	1Ph	3
	60C-439A	Strain Relief	3Ph	3
40	60B-440	Strain Relief		1
	60B-440A	Strain Relief		1
41	60C-441	Motor Label	1Ph	1
	60C-441A	Motor Label	3Ph	1
42	TS-0720091	Lock Washer	3/8"	3
43	TS-0570031	Hex Nut	3/8"-16	3
45	TS-081C022	Phillips Pan Head Machine Screw	#10-24x3/8"	2
46	60C-446	Control Cord		1
47	60B-447	Strain Relief		1
	60B-447A	Strain Relief		1
48	60B-448	Switch Plate		1
49	TS-1533042	Phillips Pan Head Machine Screw	M5x0.8x12	4
50	PM2700-440	Wide Stripe		sold per ft.
51	PM2700-441	Narrow Stripe		sold per ft.

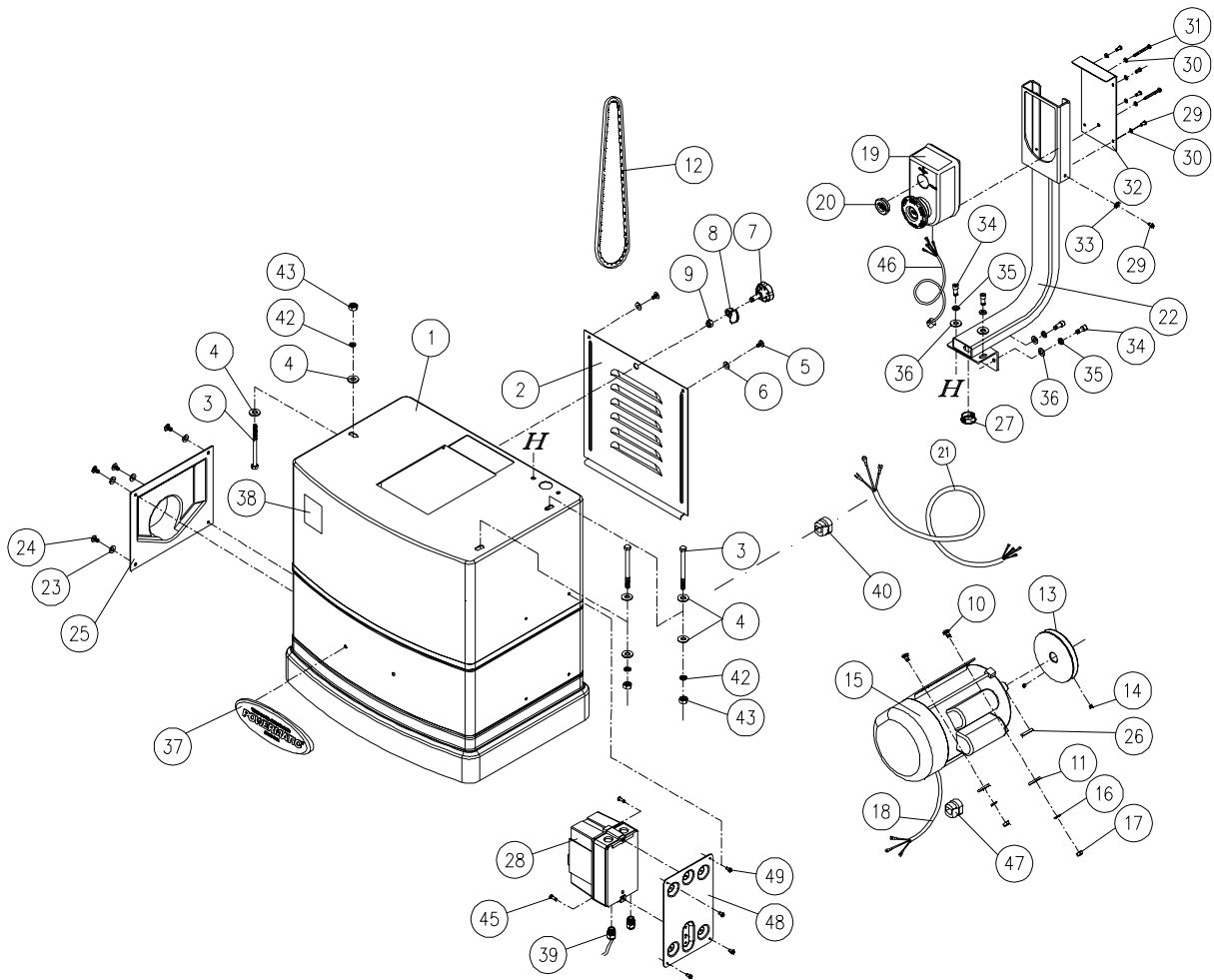

Electrical Connections – Single Phase, 230 Volt

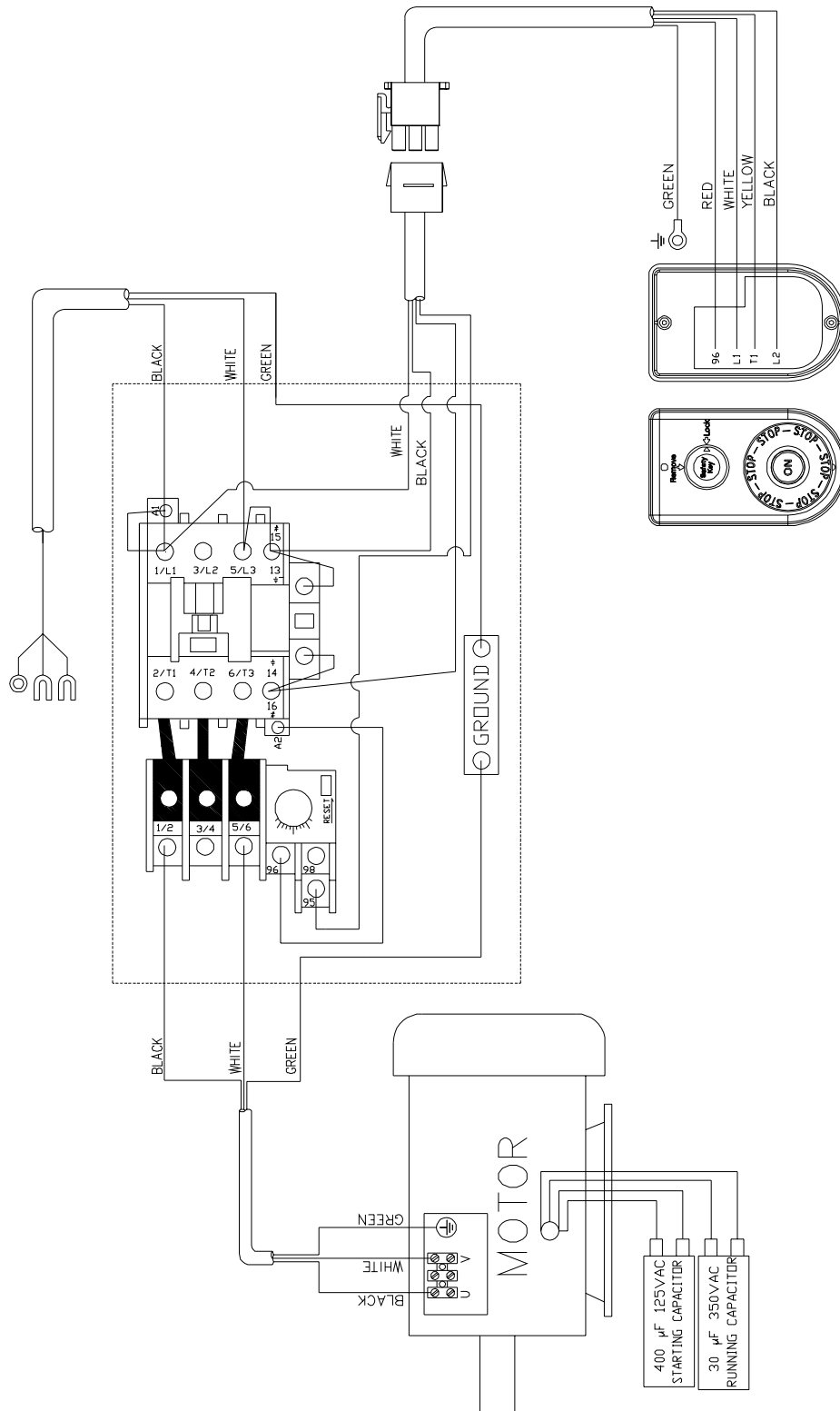

Electrical Connections – 3 Phase, 230 Volt

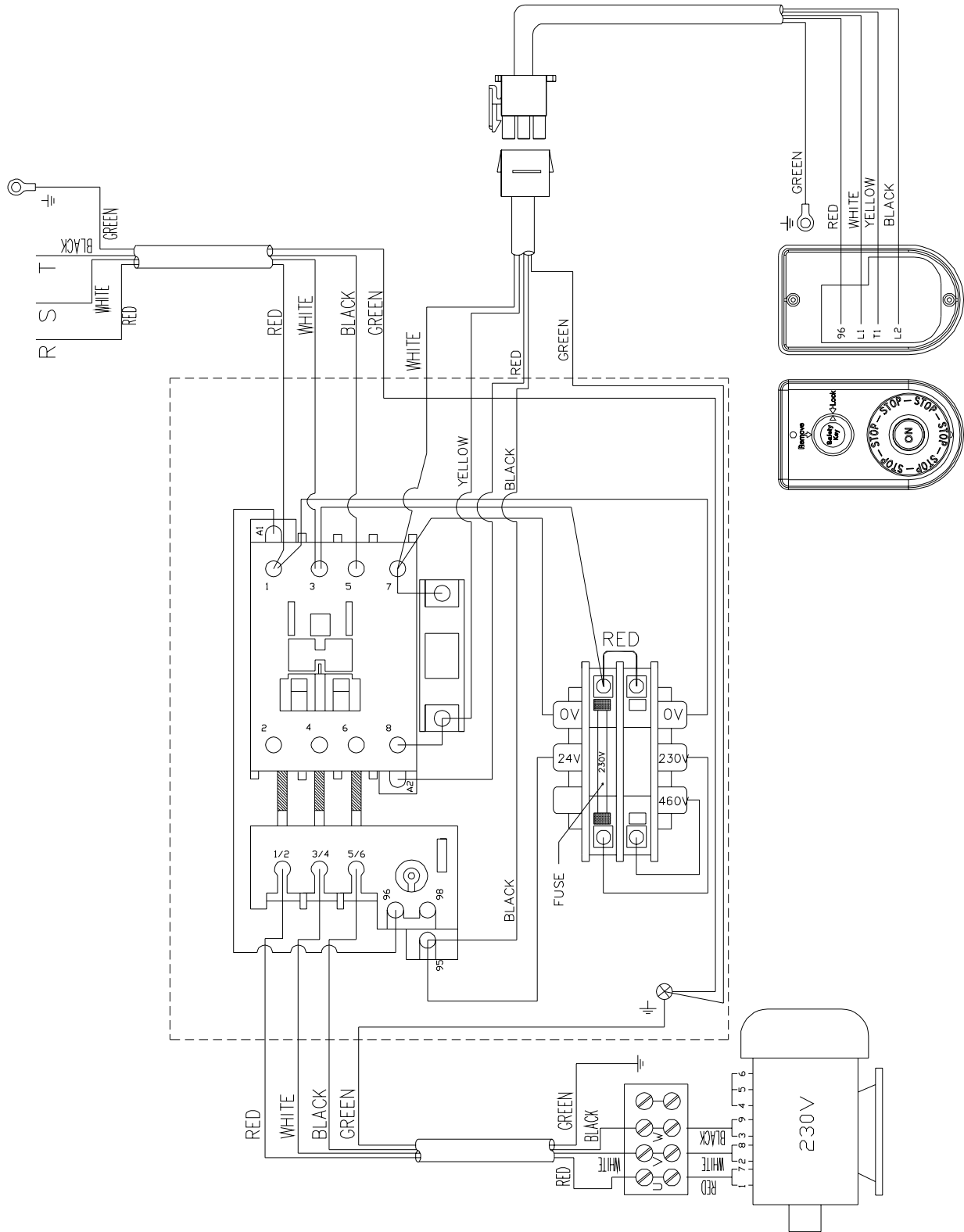

Electrical Connections – 3 Phase, 460 Volt

