

Angle Grinder - 0 601 706 239 - 1706E

www.powertools-aftersaleservice.com



BOSCH

Item	Part Number	Description	Illustration	Price	Quantity	Price Group
2	1 604 220 307	Field 100-120V	1	-,-	1	34
3/50	1 606 610 132	Fan	1	-,-	1	12
4	1 607 200 137	Switch	1	-,-	1	24
4/10	2 910 110 048	Pan head screw DIN 85-AM3x6-CUZN	1	-,-	2	10
5	2 604 460 188	Power supply cord USA/CDN 2,68m 2 x 0,82mm SJ 18/2	1	-,-	1	26
6	2 600 703 013	Grommet Ø7,6-Ø8,2x95 MM	1	-,-	1	13
7	1 601 302 017	Fastening Clamp	1	-,-	1	10
9	1 601 118 C77	Manufacturer's nameplate	1	-,-	1	15
13	2 600 905 032	Deep-Groove Ball Bearing 7x19x6	1	-,-	1	17
14	1 600 905 032	Deep-Groove Ball Bearing 8x22x7	1	-,-	1	18
24	1 605 500 228	Cover BLUE	1	-,-	1	14
25	1 605 500 226	Housing Cover BLUE	1	-,-	1	19
26	1 600 206 036	Rubber Ring	1	-,-	1	11
27	1 600 206 025	Rubber Ring	1	-,-	1	12
29	1 600 591 025	Air-Deflector Ring	1	-,-	1	13
30	1 600 591 014	Air-Deflector Ring	1	-,-	1	13
32	1 603 523 122	Grinding Spindle 5/8"	1	-,-	1	33
33	1 600 210 035	O-Ring 46,0x1,1 MM	1	-,-	1	11
35	1 600 136 013	Shim 0,1 MM THICK	1	-,-	1	13
35	1 600 136 020	Shim 0,15 MM THICK	1	-,-	1	13
35	1 600 136 014	Shim 0,2 MM THICK	1	-,-	1	13
35	1 600 136 015	Shim 0,3 MM THICK	1	-,-	1	13
37	1 600 290 016	Rotary shaft lip seal	1	-,-	1	12
40	1 600 119 011	Spring retaining ring	1	-,-	1	11
41	1 600 200 029	Plain bearing	1	-,-	1	14
45	1 603 300 016	Hex Nut M7, SW10	1	-,-	1	11
47	2 912 401 018	Tapping Screw DIN7981-ST3,9x13-C-Z	1	-,-	1	10
49	1 603 435 026	Thread-forming tap. Screw	1	-,-	4	11
50	2 912 401 420	Tapping Screw DIN7981-ST3,9x19-F-Z	1	-,-	1	10
51	1 607 233 108	Speed governor 110-120V	1	-,-	1	37
55	1 603 415 005	Oval-Head Screw	1	-,-	4	10
80	3 600 150 021	Sealing disk	1	-,-	1	13
104	1 600 210 044	O-Ring 4,5x1,0 MM BLUE	1	-,-	1	10

Item	Part Number	Description	Illustration	Price	Quantity	Price Group
105	1 601 008 005	Insulating Plate	1	-,-	2	14
180	1 601 118 E49	Warning Plate	N/A	-,-	1	15
301/1	1 605 108 208	Motor Housing BLUE	1	-,-	1	23
301/16	1 601 323 025	Brush Holder	1	-,-	2	15
301/17	1 604 652 013	Spiral Spring	1	-,-	2	11
301/18	1 602 026 057	Switch Handle BLACK	1	-,-	1	11
301/19	1 604 611 026	Compression Spring	1	-,-	1	10
301/20	1 602 319 011	Adjusting Slide	1	-,-	1	11
301/48	2 912 401 005	Tapping Screw DIN7981-ST2,9x9,5C-Z	1	-,-	2	10
650/10	1 602 025 031	Auxiliary Handle M10, Ø37x115 MM ANTI-VIBRATION	2	-,-	1	28
650/20	1 605 703 127	Clamping-Flange 5/8"-FL	2	-,-	1	36
650/30	1 607 950 052	Pin-Type Face-Wrench	2	-,-	1	15
650/30	1 607 950 052	Pin-Type Face-Wrench	2	-,-	1	15
650/40	3 603 340 503	Round Nut 5/8"	2	-,-	1	28
650/50	3 603 340 501	Clamping-Flange 5/8"-FL+B	2	-,-	1	17
651	1 605 510 363	Protective Cover Ø 150 MM	2	-,-	1	31
803	1 604 010 656	Armature With Fan 100-120V	1	-,-	1	43
808	1 601 118 F72	Nameplate	1	-,-	1	15
810	1 607 014 173	Carbon-Brush Set	1	-,-	1	24
821	1 605 806 451	Gear Housing	1	-,-	1	35
821/010	1 607 000 253	Push-Button BLACK	1	-,-	1	12
828	1 607 000 348	Bearing Flange Ø 150 MM	1	-,-	1	27
838	1 607 000 A4P	Set Of Gearwheels	1	-,-	1	33

Illustration - Type E

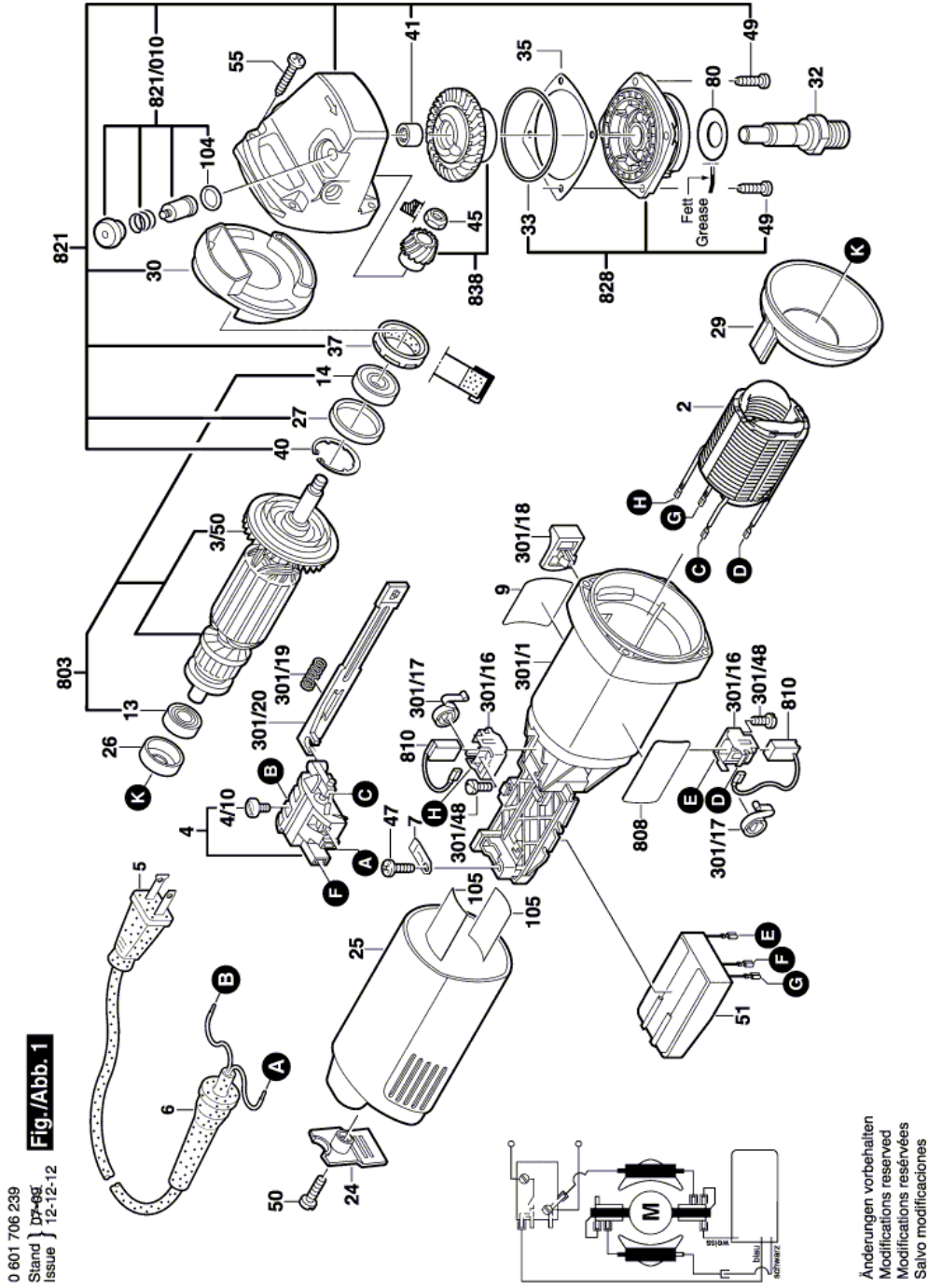
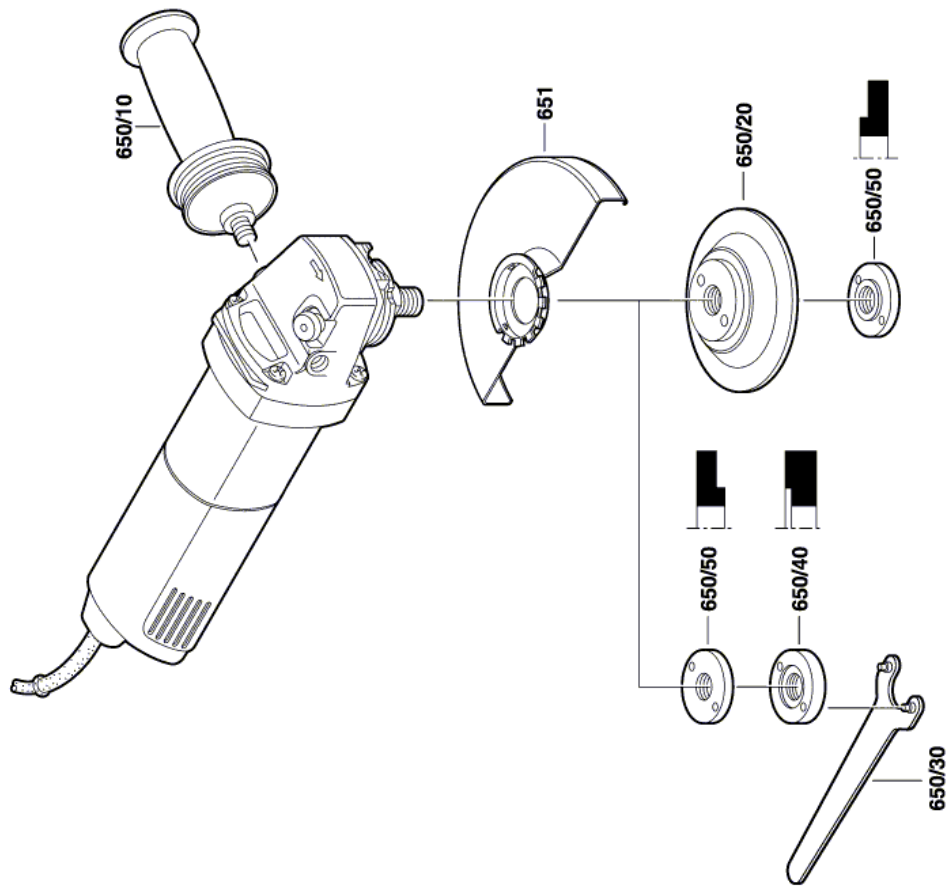

Illustration - Type E



0 601 706 239
Stand }
Issue } 04-01-20 **Fig./Abb. 2**

Änderungen vorbehalten
Modifications reserved
Modificacions reservées
Salvo modificaciones

Information subject to change without further notice.