

Parts List: Stand Assembly

Index No.	Part No.	Description	Size	Qty
1	PJ1285-101	Stand		1
2	TS-0680041	Flat Washer	3/8"	4
3	TS-0720091	Lock Washer	3/8"	4
4	TS-0060051	Hex Cap Screw	3/8"-16x1"	4
5	6292491	Cover, Dust Chute		1
6	TS-081C022	Machine Screw, Pan Head, Phillips	#10-24x3/8"	5
7	6292493	Motor Assembly, Motor With Pulley	3HP, 3Ph	1
	6295366	Motor Assembly, Motor With Pulley	3HP, 1Ph	1
8	6292494	Plate, Switch		1
9	6295112	Contactora	1Ph	1
	6292495	Contactora	3Ph, 230V	1
	PJ1285-109	Contactora	3Ph, 460V	1
10	PJ1285-110	Clamp	3Ph	3
	PJ1285-110A	Clamp	1Ph	3
11	6292497	Box, Junction		1
12	6292498	Strip, Terminal		1
13	TS-081C062	Machine Screw, Pan Head, Phillips	#10-24x1"	2
14	TS-0720051	Lock Washer	#10	2
15	PJ1696-211	Switch		1
16	PJ1285-116	Hood, Dust		1
17	TS-0720071	Lock Washer	1/4"	9
18	TS-0050011	Hex Cap Screw	1/4"-20x1/2"	7
19	6292507	Cover, Pulley		1
20	6292508	Bolt		3
22	TS-0561031	Hex Nut	3/8"-16	6
23	TS-059303	Cap Nut	3/8"-16	3
24	6292510	Door, Access		1
25	6292511	Handle Assembly		1
26	PJ1285-126	Washer	3/8"x3/4 OD	1
27	PJ1696-210	Switch Arm		1
28	TS-1533052	Machine Screw, Pan Head, Phillips	M5x16	2
29	PJ1285-129	Switch Cord		1
30	PJ1285-130	Motor Cord	1Ph	1
	PJ1285-130A	Motor Cord	3Ph	1
31	PJ1285-131	Power Cord	1Ph	1
	PJ1285-131A	Power Cord	3Ph	1
32	3312341	Powermatic Logo		1

Stand Assembly

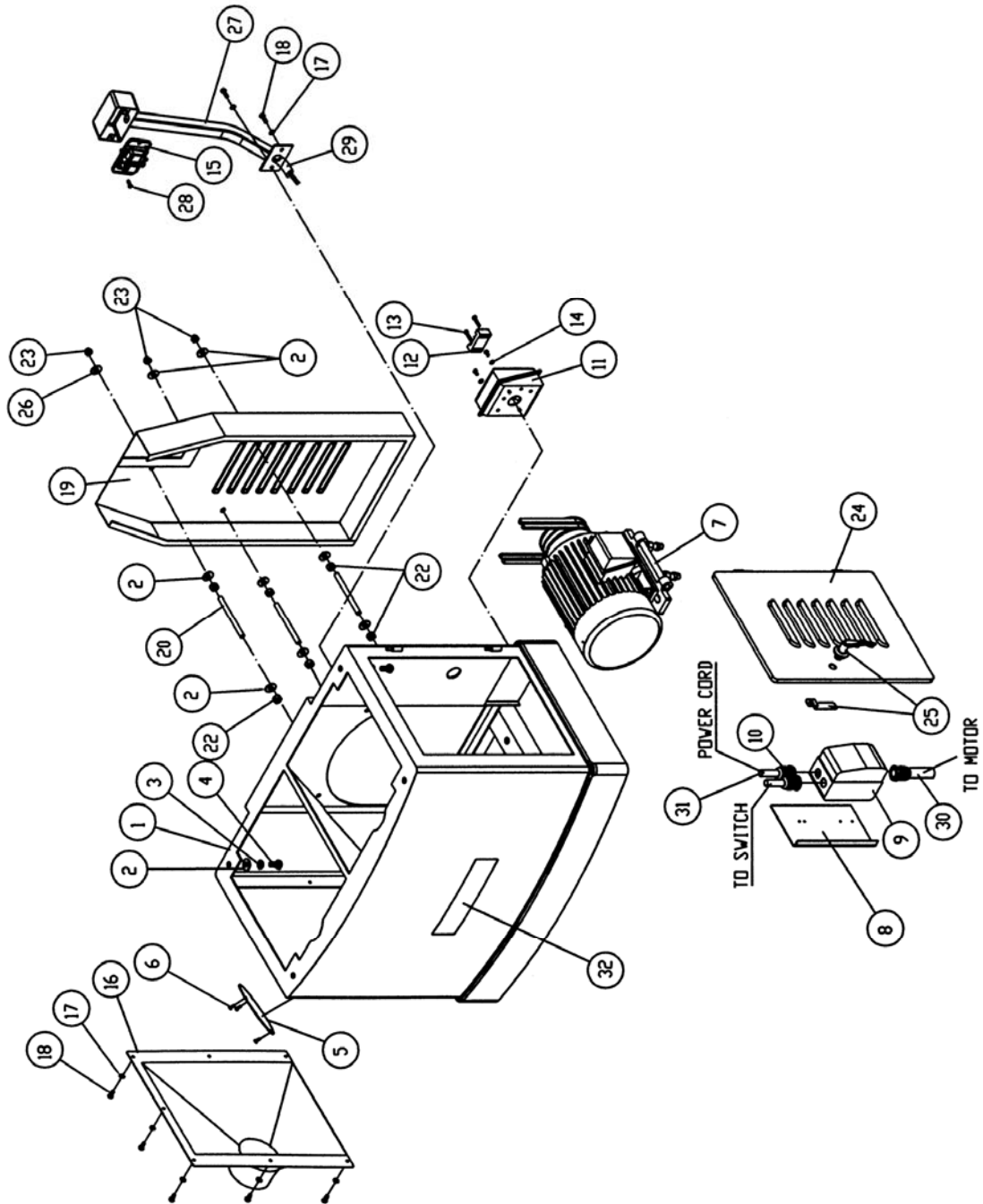

Parts List: Table Assembly

Index No.	Part No.	Description	Size	Qty
1	6292525	Base		1
2	6292526	Bar, Table Raising Link		2
3	6292527	Bracket		2
4	TS-0680041	Lock Washer	3/8"	8
5	TS-0209051	Socket Head Cap Screw	3/8"-16x1"	4
6	6292530	Bushing		8
7	6292531	Support		8
8	6292532	Bushing		8
9	6292533	Axis, Pivot		4
10	6292534	Screw		2
11	TS-0680061	Flat Washer	1/2"	2
12	6292536	Handwheel		2
13	6292537	Handle		2
14	TS-0209061	Socket Head Cap Screw	3/8"-16x1-1/4"	4
15	TS-1490041	Hex Cap Screw	M8x25	2
16	TS-1540061	Hex Nut	M8	4
17	6292540	Knob		2
18	6292541	Axis, Pivot		8
19	TS-0208071	Socket Head Cap Screw	5/16"-18x1-1/4"	8
20	6292543	Bar, Table Raising Link		2
21	6292544	Axis, Pivot		4
22	6292545	Screw		8
23	TS-0561031	Hex Nut	3/8"-16	24
24	6292547	Tube		2
25	6292548	Spring		4
26	PJ1696-509	Spring Holding Bolt		4
27	6292550	Straight Cutterhead Assembly		1
	PJ1285-600	Helical Cutterhead Assembly		1
28	TS-1491041	Hex Cap Screw	M10x30	2
29	6292551	Infeed Table		1
30	6292552	Lip, Table		1
31	TS-1505061	Socket Head Cap Screw	M10x40	8
32	6292554	Deflector, Dust		1
33	TS-081C062	Machine Screw, Pan Head, Phillips	#10-24x1"	5
34	TS-0680011	Flat Washer	3/16"	5
35	TS-0560071	Hex Nut	#10-24	5
36	6292558A	Outfeed Table		1
37	6292559	Lip, Table		1
38	6292560	Guard Assembly		1
39	TS-2361101	Lock Washer	M10	2
40	PJ1285-240	Pointer		1
41	PJ1285-241	Scale		1
42	TS-0680011	Flat Washer	3/16"	1
43	TS-081C022	Machine Screw, Pan Head, Phillips	#10-24x3/8"	1
44	TS-0680041	Flat Washer	3/8"	24
45	TS-0271051	Socket Set Screw	3/8"-16x1/2"	4
46	TS-0271031	Socket Set Screw	3/8"-16x3/8"	4
47	TS-0561011	Hex Nut	1/4"-20	6
48	6285917	Push Block		2
49	PJ1285-249	Set Screw	M8x35	2
50	PJ1285-250	Dust Deflector		1
51	PJ1285-251	Steel Plate		1
52	TS-1502051	Socket Head Cap Screw	M5x20	2

Table Assembly

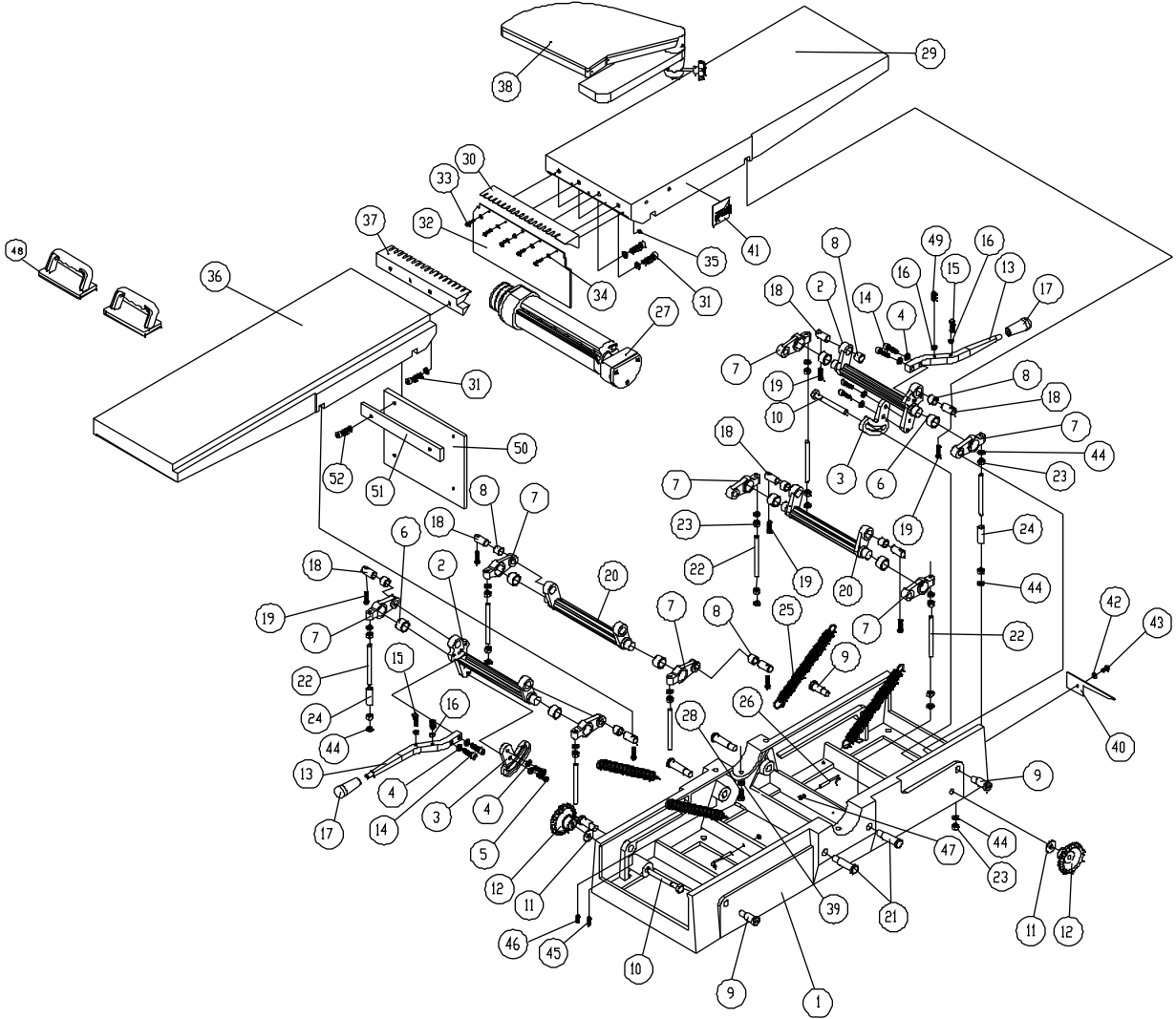

Parts List: Motor Pulley Assembly

Index No.	Part No.	Description	Size	Qty
1	6292512	Motor	3HP 3Ph	1
	6292512-MF	Motor Fan (not shown)		1
	6292512-MFC	Motor Fan Cover (not shown)		1
	6292563	Motor	3HP 1Ph	1
	6292563-MF	Motor Fan (not shown)		1
	6292563-MFC	Motor Fan Cover (not shown)		1
	6292563-CS	Centrifugal Switch (not shown)		1
	6292563-SC	Starting Capacitor (not shown)	400MFD, 250VAC	1
	6292563-RC	Running Capacitor (not shown)	50uf, 350VAC	1
2	6292513	Pulley	3Ph	1
	6294246	Pulley	1Ph	1
3	TS-1525011	Socket Screw Screw	M10x10	1
4	6292515	Bracket, Motor		1
5	TS-0680041	Flat Washer	3/8"	3
6	TS-0720091	Lock Washer	3/8"	6
7	TS-0060081	Hex Cap Screw	3/8"-16x1-3/4"	3
8	TS-0561031	Hex Nut	3/8"-16	3
9	6292520	Plate		1
10	6292521	Rod		1
11	TS-2360121	Flat Washer	M12	2
12	TS-1540081	Hex Nut	M12	8
13	TS-1525021	Socket Set Screw	M10x12	1
14	6295367	Belt, 1PH	A-53	2
	6295357	Belt, 3PH	A-55	2
15	PJ1285-315	Key	8mmx 7mm x 55mm	1

Motor Pulley Assembly

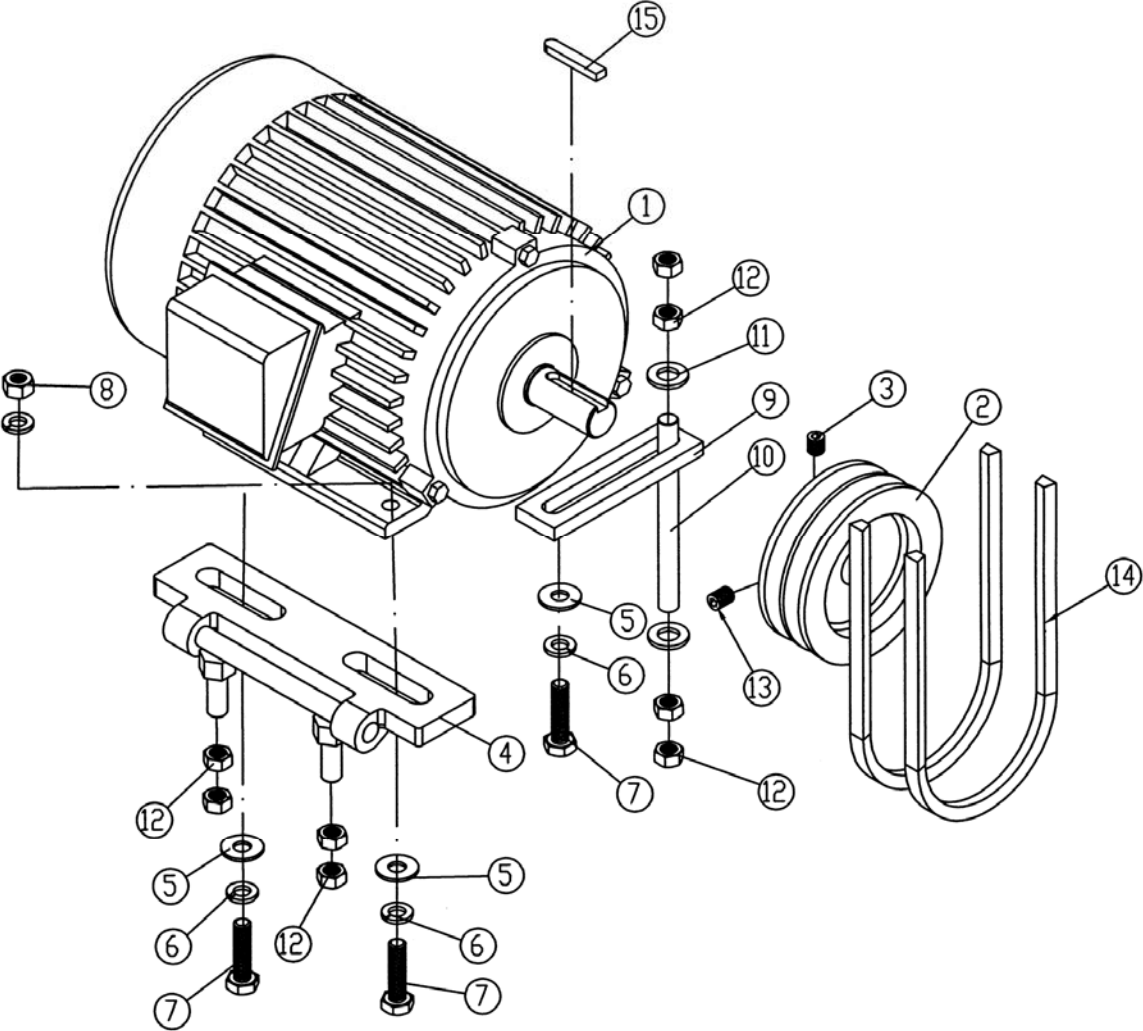

Parts List: Cutterhead Guard Assembly

Index No.	Part No.	Description	Size	Qty
1	6292581	Ledge, Rabbet		1
2	6292582	Guard		1
3	6292583	Shaft		1
4	6292584	Spring		1
5	6292585	Collar, Shaft		1
6	TS-0271071	Socket Set Screw	3/8"-16x3/4"	1
7	TS-0267071	Socket Set Screw	1/4"-20x3/4"	2
8	TS-0561011	Hex Nut	1/4"-20	2
9	6292589	Knob		1
10	TS-0720091	Lock Washer	3/8"	2
11	TS-0209031	Socket Head Cap Screw	3/8"-16x3/4"	2
12	TS-0680041	Flat Washer	3/8"	2
13	60B-272	Warning Label		1

Cutterhead Guard Assembly

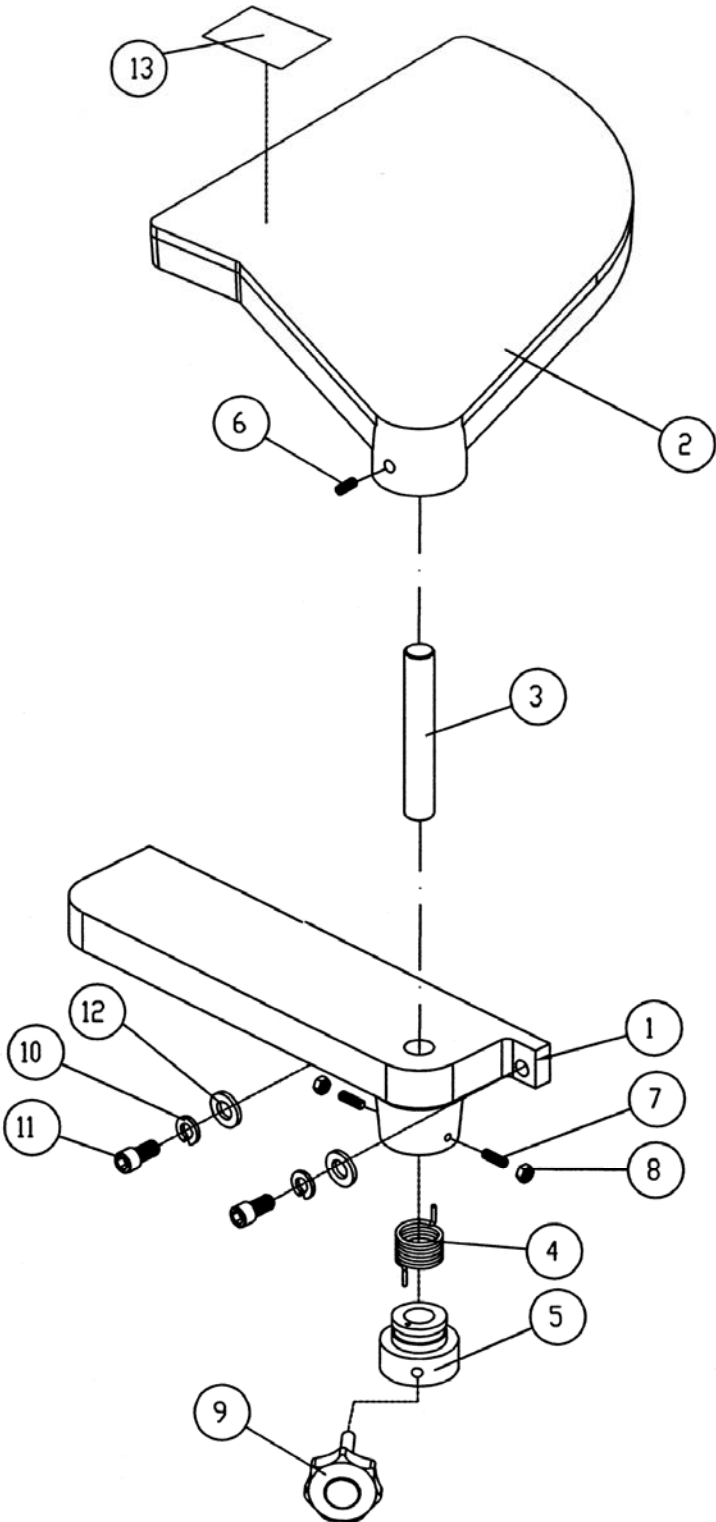

Parts List: Straight Cutterhead Assembly

Index No.	Part No.	Description	Size	Qty
	6292550	Cutterhead Assembly (Items 1 thru 19)		
1	6292561	Cutterhead		1
2	PJ1696-002	Left Bearing Housing		1
3	BB-6204ZZ	Bearing	6204ZZ	2
4	PJ1696-005	Right Bearing Housing		1
5	BB-6206ZZ	Bearing	6206ZZ	2
6	6292566	Bearing Washer		1
7	6292568	Hex Cap Screw (LH Threads)	M8x20	1
8	TS-1503051	Socket Head Cap Screw	M6x20	6
9	6292572	Pulley		1
10	6292573	Key	8mmx8mmx60mm	1
11	6292574	Pulley Washer		1
12	TS-2361101	Lock Washer	M10	1
13	6292576	Hex Cap Screw (LH Threads)	M10x25	1
14	6292577	Spring		6
15	6292535	Knife (set of 3)		1
16	6292579	Gib, Knife(set of 3)		1
17	6292580	Gib Screw		18
18	PJ1696-004	Left Bearing Cap Plate		1
19	PJ1696-006	Right Bearing Cap Plate		1
	PJ1285-KSGA	Knife Setting Gauge Assembly (Items 20 thru 23)		1
20	PJ1285-520	Handle		1
21	PJ1285-521	Setting Gauge		2
22	TS-1482051	Hex Cap Screw	M6x25	2
23	TS-2361061	Lock Washer	M6	2

Straight Cutterhead Assembly

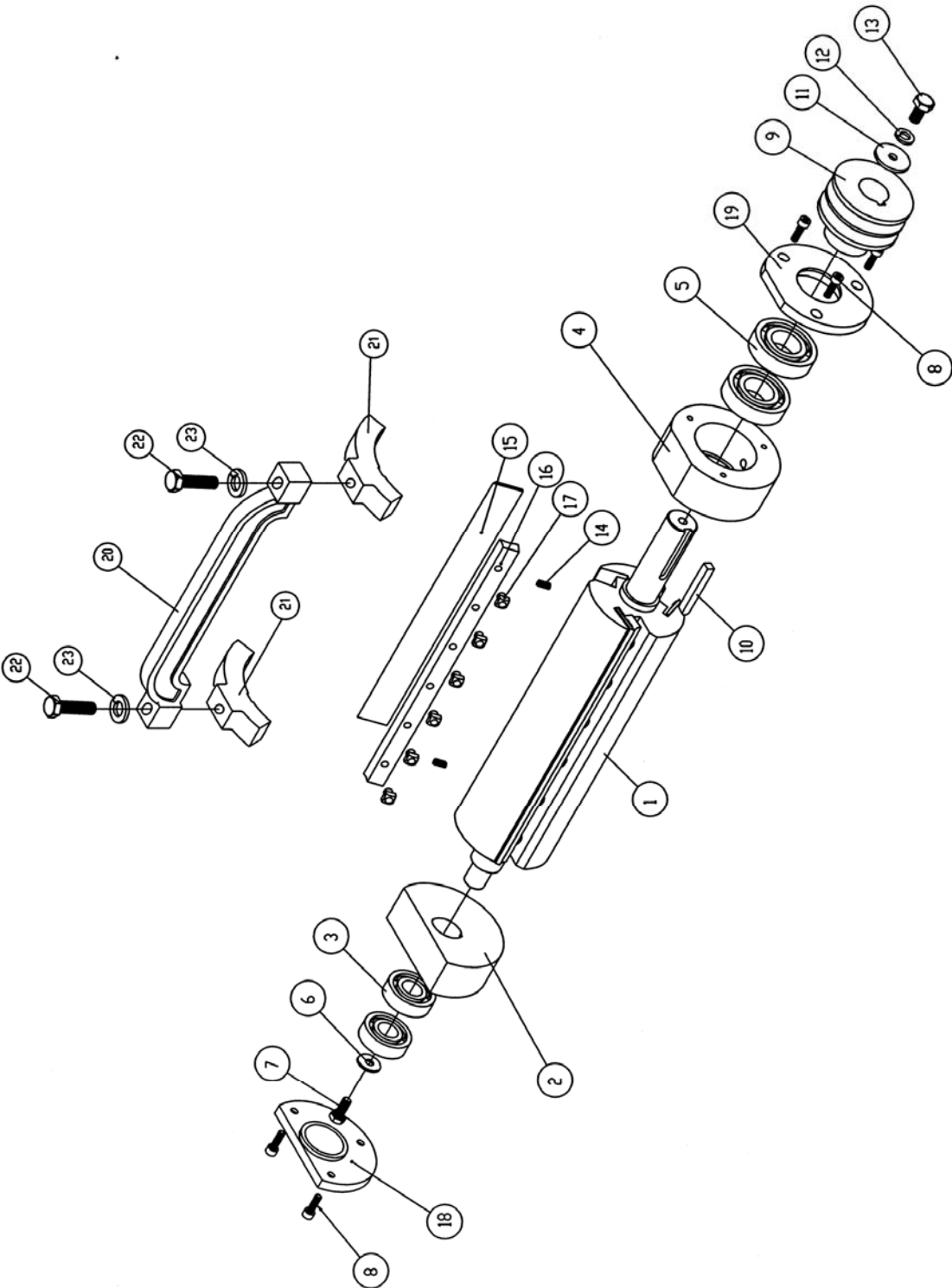

Parts List: Helical Cutterhead Assembly

Index No.	Part No.	Description	Size	Qty
	PJ1285-600	Cutterhead Assembly (Items 1 thru 22)		
1	PJ1285-601	Cutterhead		1
2	PJ1696-002	Left Bearing Housing		1
3	BB-6204ZZ	Ball Bearing	6204ZZ	2
4	6292566	Bearing Washer		1
6	TS-1490031	Hex Cap Screw	M8x20	1
7	PJ1696-004	Left Bearing Cap Plate		1
8	TS-1503051	Socket Head Cap Screw	M6x1.0Px20L	6
9	PJ1696-005	Right Bearing Housing		1
10	BB-6206ZZ	Bearing	6206ZZ	2
11	PJ1696-006	Right Bearing Cap Plate		1
12	6292573	Key	8mm x 8mm x 60mm	1
13	6292572	Cutterhead Sheave		1
14	6292574	Pulley Washer		1
15	TS-2361101	Lock Washer	M10	1
16	TS-1491021	Hex Cap Screw	M10x20	1
17	PJ1696-010	Gib		44
18	PJ1696-011	Carbide Insert Knife-Rabbit (Sold in pkg of 2)		2
19	6400013	Carbide Insert Knife (Sold in pkg of 10)		42
20	PJ1696-012	Gib Nut		44
21	PJ1696-013	Gib Screw		44
22	PJ1696-015	Gib Pin	Ø 2x 8	88

Helical Cutterhead Assembly

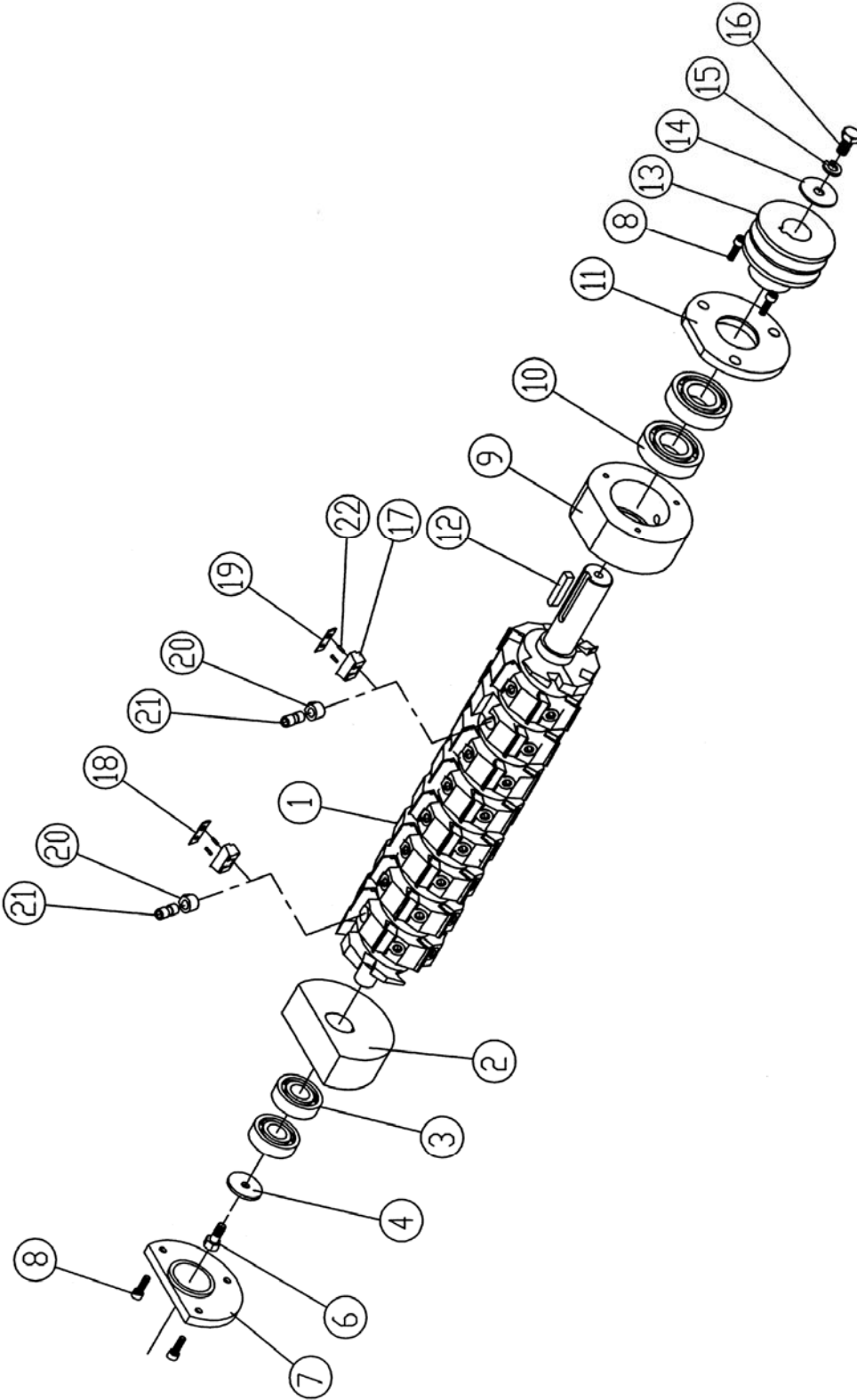

Parts List: Fence Assembly

Index No.	Part No.	Description	Size	Qty
1	6292592	Support, Fence		1
2	6292593	Bracket		1
3	6292594	Column, Gear		1
4	6292595	Guard		1
5	TS-1503031	Socket Head Cap Screw	M6x12	2
6	TS-1550071	Flat Washer	M10	4
7	TS-2361101	Lock Washer	M10	4
8	TS-1491041	Hex Head Bolt	M10x30	2
9	TS-1505041	Socket Head Cap Screw	M10x30	2
10	6292601	Shaft, Gear		1
11	6292602	Handwheel		1
12	6292603	Lock Handle		1
13	6295358	Collar		1
14	6292604	Bolt		1
15	TS-0720111	Lock Washer	1/2"	2
16	6295886	Socket Head Cap Screw	1/2"-12NCx1-1/4"	2
17	6292605	Bracket, Fence		1
18	6292606	Support		1
19	6292607	Pin		6
20	TS-1523061	Socket Set Screw	M6x20	2
21	TS-1540061	Hex Nut	M8	4
22	TS-1490031	Hex Cap Screw	M8x20	2
23	6292611	Bracket, Left		1
24	6292612	Bracket, Right		1
25	6292613	Shaft		1
26	TS-2360121	Flat Washer	M12	2
27	6292615	Lock Handle		1
28	TS-2331121	Cap Nut	M12	1
29	6292823	Spring Pin	Ø5x20	1
30	6295359	Clamp, Rear		2
31	6295360	Fence		1
32	TS-1540081	Hex Nut	M12	1
33	6295362	Rod		1
34	6292540	Knob		1
35	6295364	Block		1
36	6295365	Bushing		1
37	TS-2361081	Lock Washer	M8	1
38	TS-1490061	Hex Cap Screw	M8x35	1
39	PJ1285-739	Cover		1
40	PJ1696-105	Block		1
41	TS-1501051	Socket Head Cap Screw	M4x16	1
42	TS-1523041	Socket Set Screw	M6x12	1
43	TS-1540071	Hex Nut	M10	1
44	TS-1550061	Flat Washer	M8	1
45	TS-1490061	Hex Cap Screw	M8x35	2
46	TS-1505021	Socket Head Cap Screw	M10x20	4

Fence Assembly

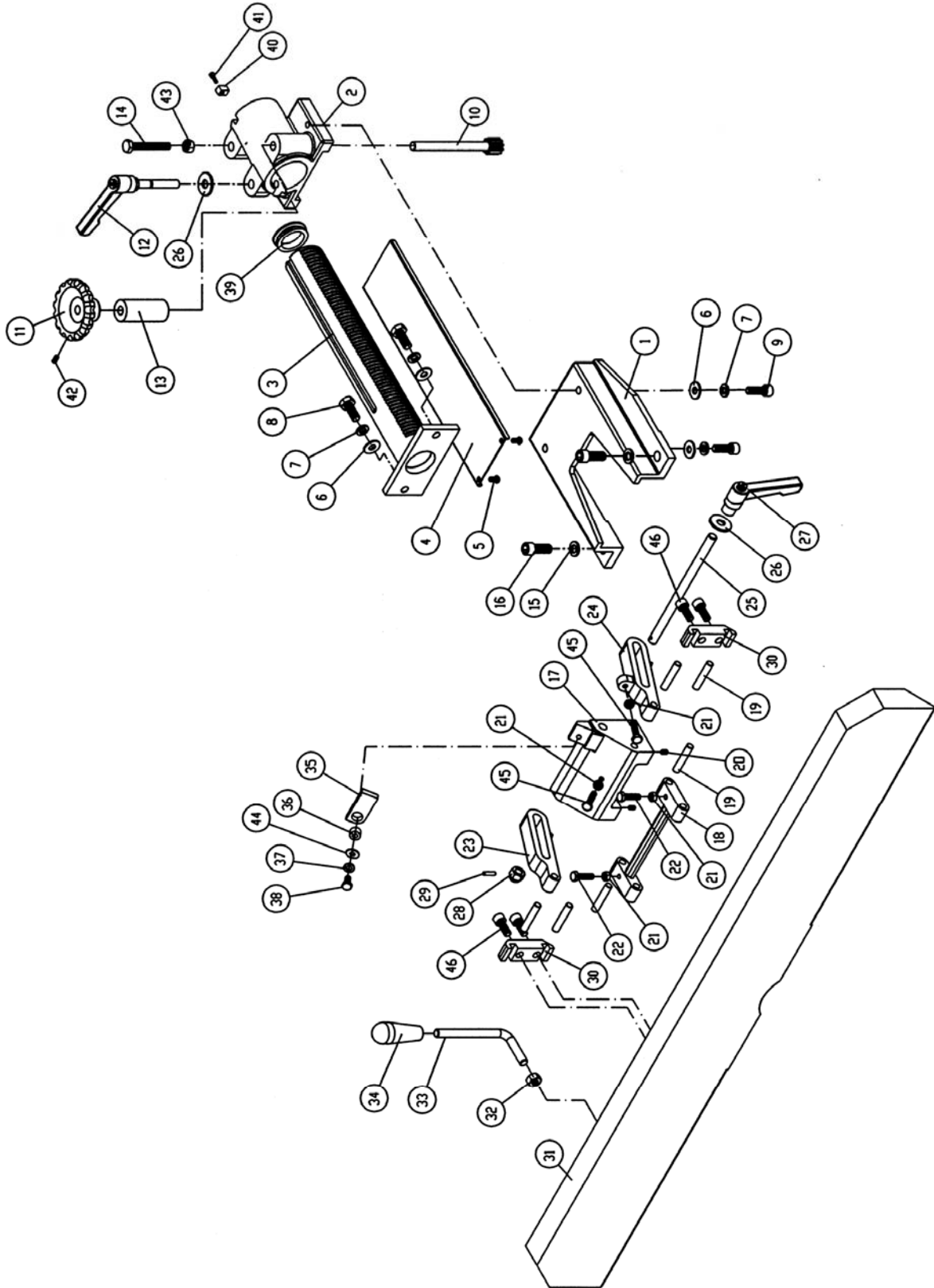

Electrical Connections – 1 Phase

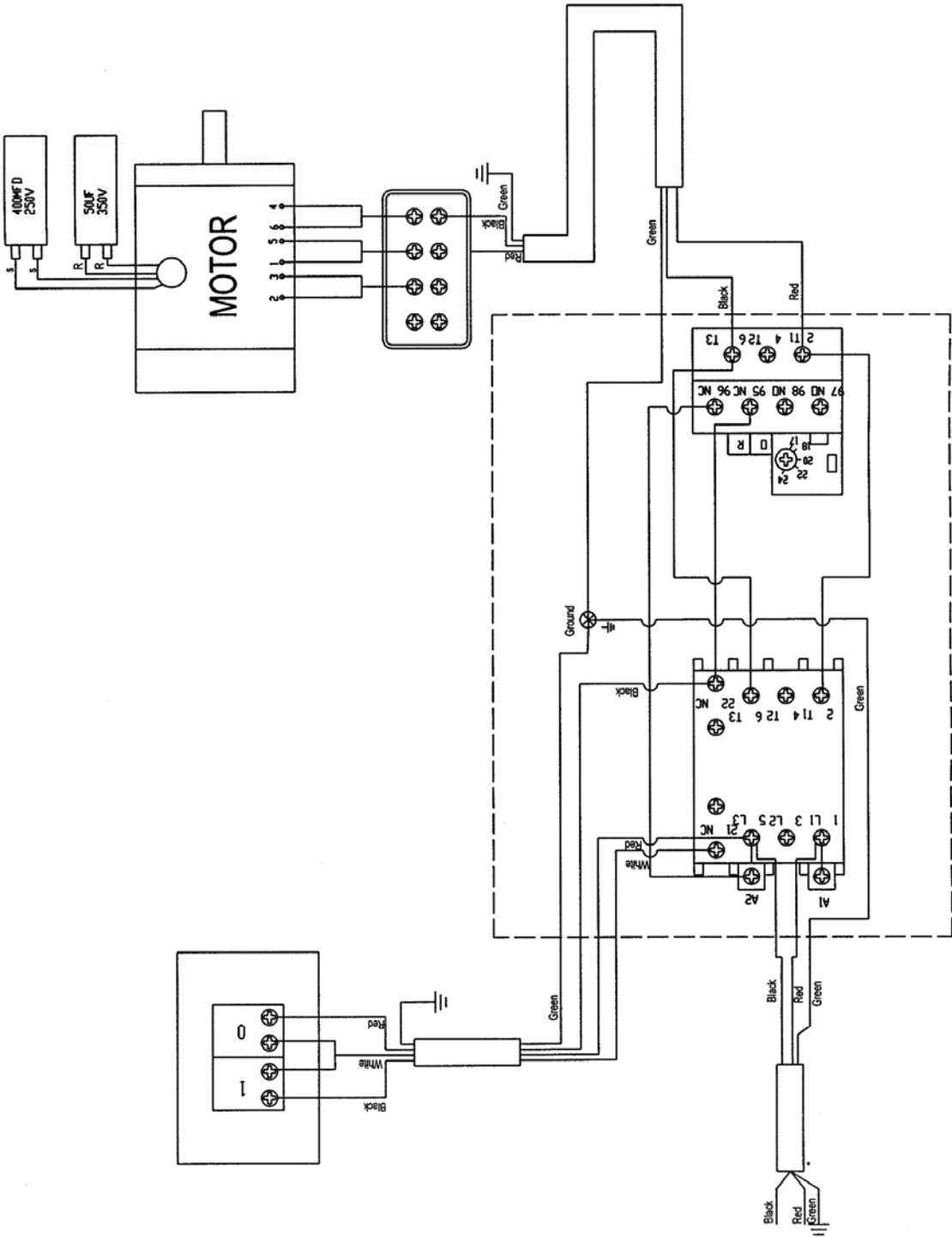

Electrical Connections – 3 Phase

