

Parts List: Base Assembly

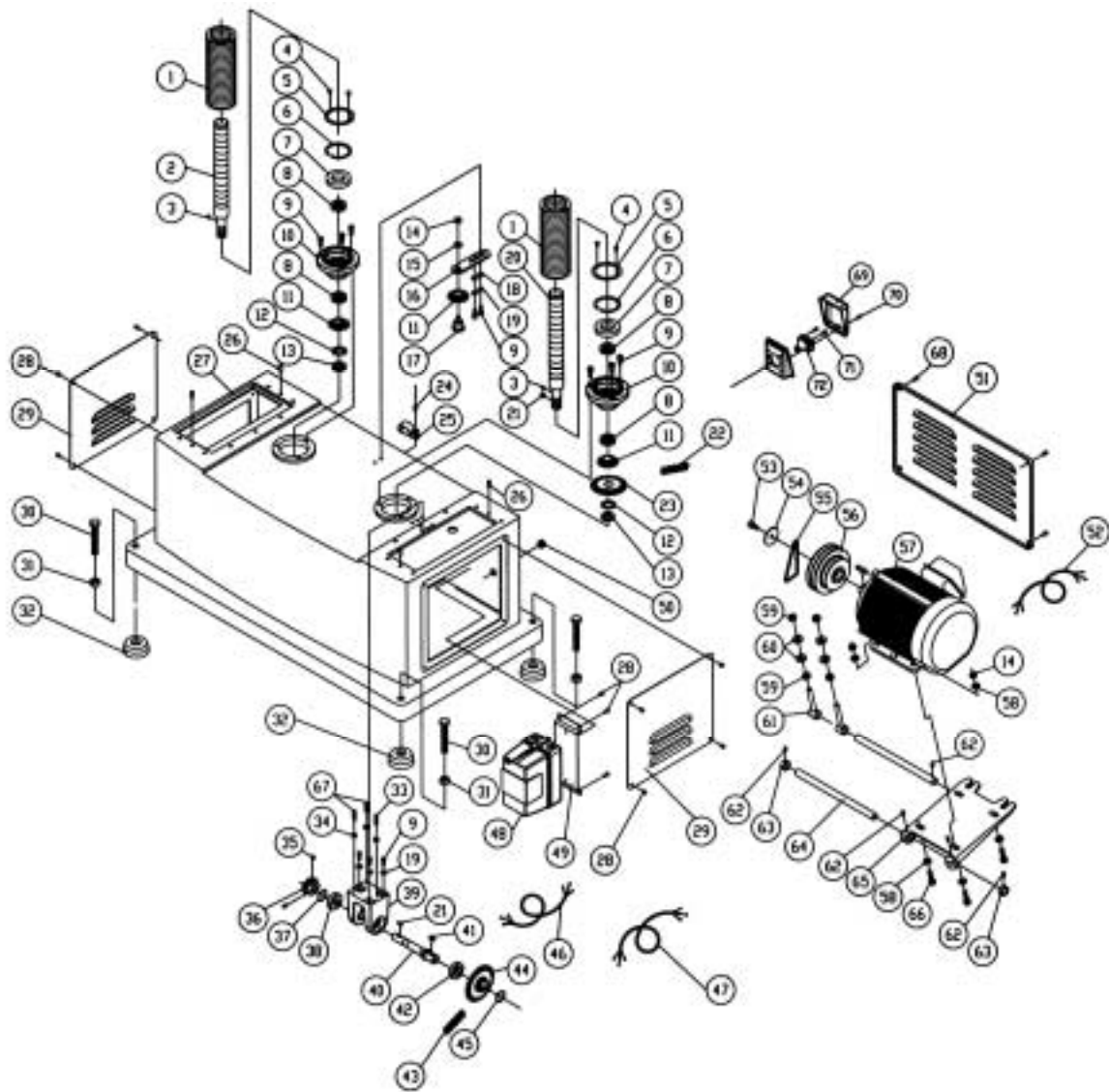

Index No.	Part No.	Description	Size	Qty
1.....	6012068.....	Rubber Boot.....		2
2.....	6012069.....	Lead Screw.....		1
3.....	6293370.....	Key.....	5 x 5 x 10.....	2
4.....	6012070.....	Screw w/ Washer.....	M4x0.7Px8Lg / 4mmx10x0.8T.....	4
5.....	6012071.....	Bushing.....		2
6.....	6012072.....	R-Ring.....	RTW-68.....	2
7.....	6012073.....	Ball Bearing.....	6008-2NSE.....	2
8.....	6012074.....	Bearing.....	51105.....	4
9.....	6012066.....	Socket Head Cap Screw.....	M8 x 1.25P x 25Lg.....	11
10.....	6012075.....	Bracket.....		2
11.....	6012076.....	Sprocket.....		3
12.....	6012077.....	Washer.....	25mm.....	2
13.....	6012078.....	Nut.....	M25 x 1.5.....	2
14.....	6012079.....	Hex Nut.....	M10 x 1.5P.....	5
15.....	6012080.....	Flat Washer.....	10mm x 25 x 3T.....	1
16.....	6012081.....	Rocker Arm.....		1
17.....	6012082.....	Shaft.....		1
18.....	6012083.....	Flat Washer.....	8.5mm x 19 x 2T.....	2
19.....	6012067.....	Spring Washer.....	8.2mm x 15.4.....	5
20.....	6012084.....	Lead Screw.....		1

21	6292745	Key	5 x 5 x 16	2
22	6012085	Chain	#40 x 79pcs	1
23	6012086	Bevel Gear		1
24	6012087	Screw	M5 x 0.8P x 10Lg	4
25	6012088	Strain Relief Clip	ACC-3	4
26	6012089	Pin		4
27	6012090	Base		1
28	6012091	Screw	M6 x 1.0P x 10Lg	12
29	6012092	Cover		2
30	6012093	Special Hex Screw		4
31	6012094	Hex Nut	M16 x 2.0	4
32	6012095	Foot		4
33	6012096	Set Screw	M8 x 1.25P x 30Lg	1
34	6012097	Hex Nut	M8 x 1.25	3
35	6012098	Set Screw	M5 x 0.8P x 5Lg	2
36	6012099	Bevel Gear		1
37	6012100	S-Ring	STW-20	1
38	6012101	Ball Bearing	6204-ZZ	1
39	6012102	Support Block		1
40	6012103	Shaft		1
41	6012104	Key	8 x 7 x 18	1
42	6012105	Ball Bearing	6005-ZZ	1
43	6012106	Chain	#40 x 107pcs	1
44	6012107	Sprocket		1
45	6012052	S-Ring	STW-25	1
46	6012109	Switch Cord		1
47	6012110	Power Cord	1Ph	1
	6012267	Power Cord	3Ph	1
48	6012111	Switch	460V/3Ph	1
	6012045	Switch	230V/1Ph	1
	6012294	Switch	230V/3Ph	1
49	6012112	Switch Plate		1
50	6012113	Strain Relief Bushing	M20	1
51	6012114	Cover		1
52	6012115	Motor Cord	1Ph	1
	6012266	Motor Cord	3Ph	1
53	6012048	Socket Head Cap Screw	M10 x 1.5P x 20Lg	1
54	6012116	Washer		1
55	6012117	Belt	A56	1
56	6012118	Motor Pulley		1
57	6012108	Motor	7.5HP 1Ph 230V	1
	6012108-SC	Start Capacitor	200MFD, 250VAC	2
	6012108-RC	Run Capacitor	20μF, 450VAC	1
	6012108-RC2	Run Capacitor	35μF, 450VAC	1
	6012119	Motor	7.5HP 3Ph 230/460V	1
	2210-271	Key	8x7x40mm	1
58	6012120	Flat Washer	10.3mm x 23 x 2T	8
59	6012121	Hex Nut	M12 x 1.75	4
60	6012122	Flat Washer	13mm x 28 x 3T	4
61	6012123	Adjusting Bolt		2
62	6012124	Set Screw	M8 x 1.25P x 12Lg	5
63	6012125	Spacer		2
64	6012126	Shaft		2
65	6012127	Motor Plate		1
66	6012128	Hex Screw	M10 x 1.5P x 40Lg	4
67	6012129	Set Screw	M8 x 1.25P x 20Lg	2
68	6012130	Flat Head Screw	M6 x 1.0P x 20Lg	4
69	6012269	Terminal Cover		1
70	6012270	Screw	3/16-24NC x 1/4	1
71	6012271	Screw	M5 x 0.8P x 20L	2
72	6012272	Terminal Plate		1

Gearbox Assembly

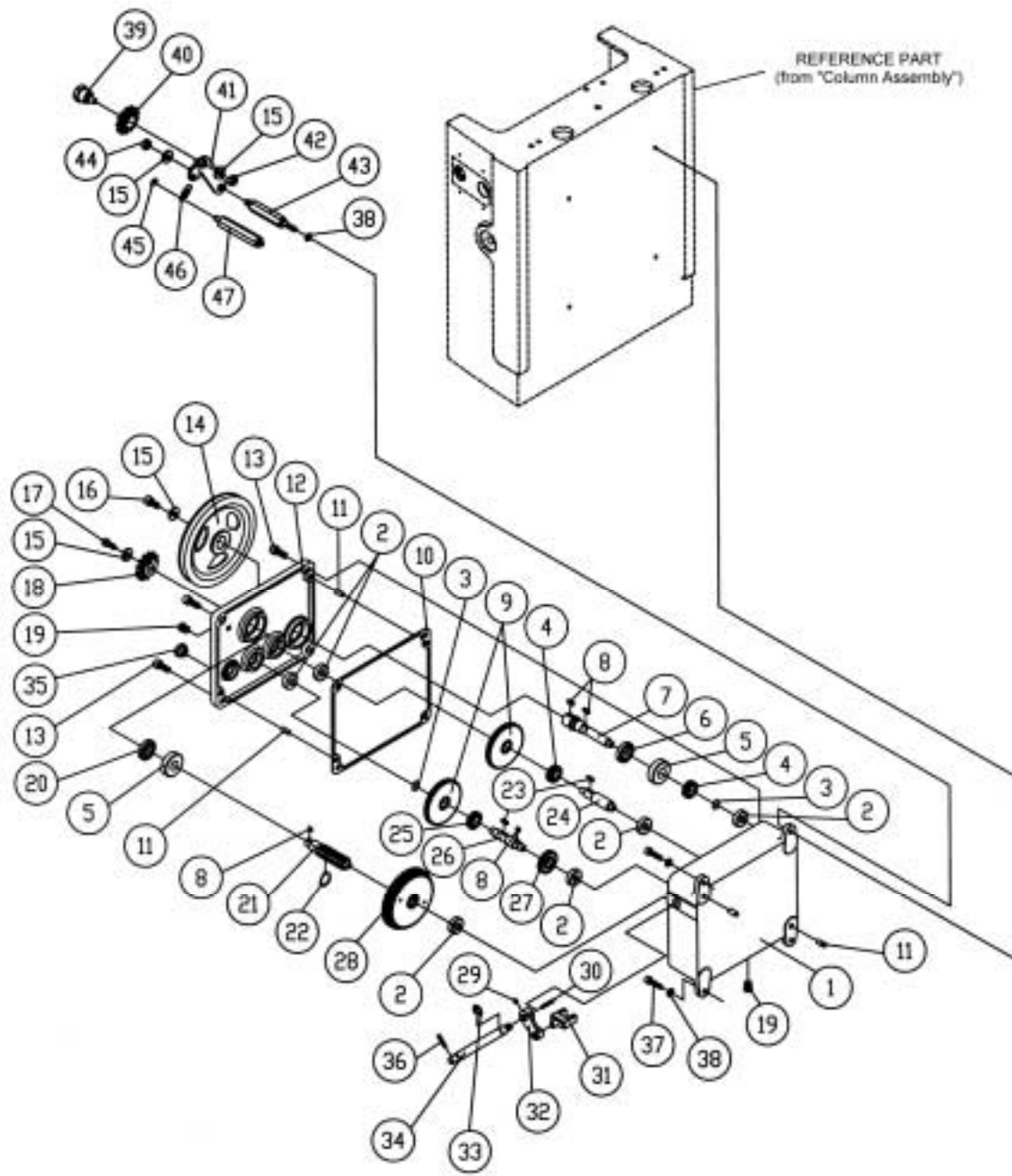

Parts List: Gearbox Assembly

Index No.	Part No.	Description	Size	Qty
	201-100	Gearbox Assembly		1
1	6012034	Gearbox Body		1
2	6012035	Ball Bearing	6201-2NSE	6
3	6012036	S-Ring	STW-16	2
4	6012037	Gear		2
5	6012038	Ball Bearing	6204-2NSE	2
6	6012039	Oil Seal	TC24 x 40 x 8	1
7	6012040	Shaft		1
8	6293370	Key	5 x 5 x 10	4
9	6012041	Gear		2
10	6012042	Gasket		1
11	6012043	Pin		4
12	6012044	Gearbox Cover		1
13	6012142	Hex Socket Cap Screw	M10 x 1.5P x 25Lg	4
14	6012046	Pulley		1
15	6012047	Flat Washer	10mm x 25 x 3T	2
16	6012048	Socket Head Cap Screw	M10 x 1.5P x 20Lg	1
17	6012049	Socket Head Cap Screw	M8 x 1.25P x 20Lg	1
18	6012050	Sprocket		1
19	6292789	Oil Plug	PT1/4"-19UNF	2
20	33-1051-00-1	Oil Seal	TC20 x 40 x 7	1
21	6012051	Shaft		1
22	6012052	S-Ring	STW-25	1
23	6292745	Key	5 x 5 x 16	2
24	6012053	Shaft		1
25	6012054	Gear		1
26	6012055	Shaft		1
27	6012056	Gear		1
28	6012057	Gear Assembly		1
29	6012058	Set Screw	M5 x 0.8P x 5Lg	1
30	6012059	Spring Pin	4mm x 25Lg	1
31	6012060	Shift Fork		1
32	6012061	Lever		1
33	6012062	E-Ring	ETW-12	1
34	6012063	Shift Shaft		1
35	6012064	Eye Glass Oil Level		1
36	6012065	Spring Pin	5mm x 26Lg	1
37	6012066	Socket Head Cap Screw	M8 x 1.25P x 25Lg	3
38	6012067	Spring Washer	8.2mm x 15.4	4
39	6012082	Shaft		1
40	6012286	Idle Sprocket		1
41	6012287	Bracket		1
42	6012079	Hex Nut	M10 x 1.5P	1
43	6012288	Stand Off		1
44	6012289	Check Nut	M10 x 1.5P	1
45	6012290	E-Ring	ETW-7	1
46	6012291	Spring		1
47	6012292	Stand Off		1

Column Assembly

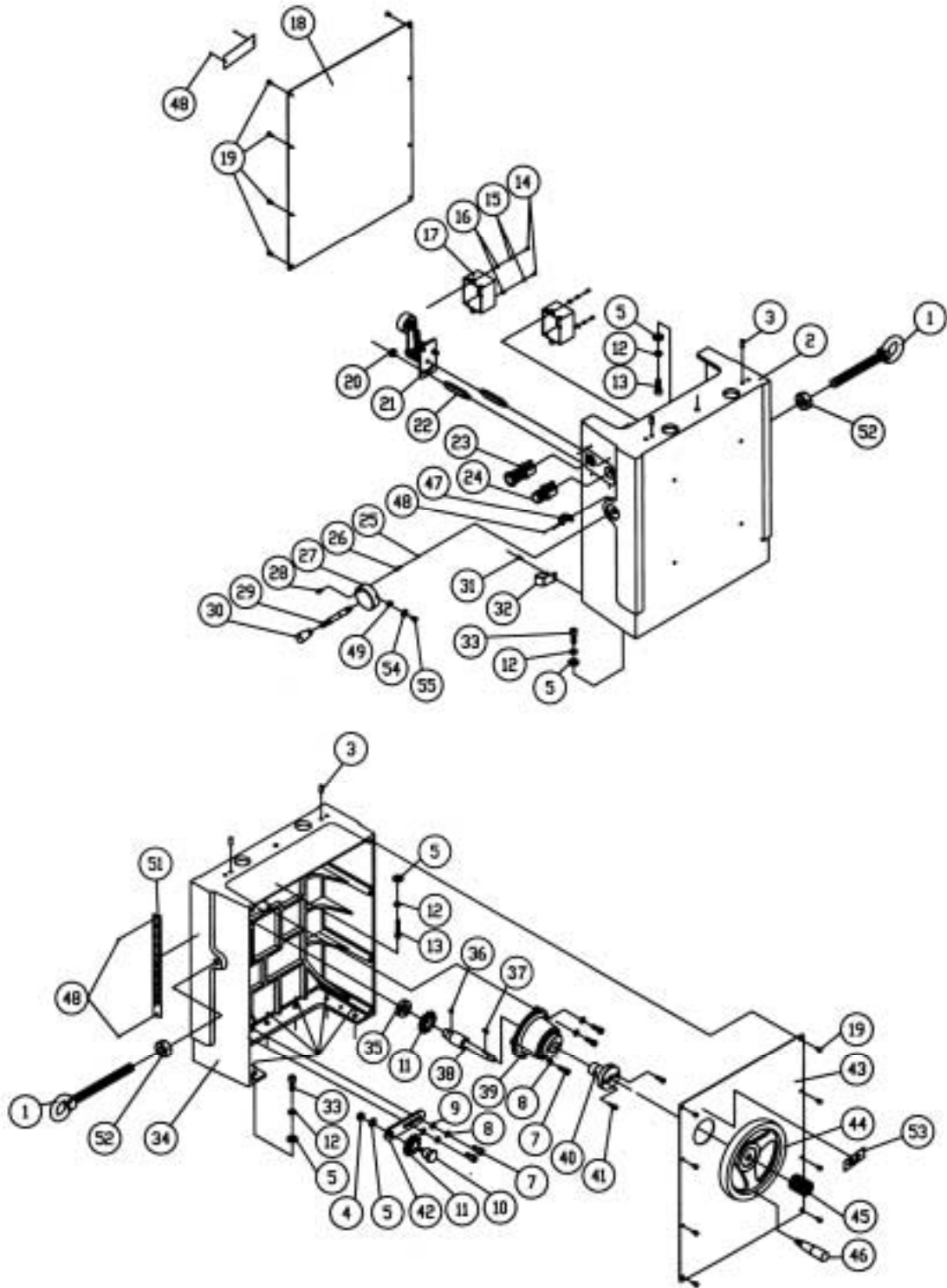

Parts List: Column Assembly

Index No.	Part No.	Description	Size	Qty
1	6012193	Lifting Eye	M20 x 2.5P x 30Lg	2
2	6012194	Left Column		1
3	6012195	Pin		4
4	6012079	Hex Nut	M10 x 1.5P	1
5	6012080	Flat Washer	10mm x 25 x 3T	17
7	6012066	Socket Head Cap Screw	M8 x 1.25P x 25Lg	6
8	6012067	Spring Washer	8.2mm x 15.4	7
9	6012083	Flat Washer	8.5mm x 19 x 2T	2
10	6012082	Shaft		1
11	6012197	Sprocket		3
12	6012157	Spring Washer	10.2mm x 18.4	16
13	6012198	Socket Head Cap Screw	M10 x 1.5P x 40Lg	2
14	6012199	Pan Head Machine Screw	M4 x 0.7P x 10Lg	4
15	6012200	Spring Washer	4.1mm x 7.7	4
16	6012201	Flat Washer	4.3mm x 10 x 1T	5
17	6012202	Switch Box		2
18	6012203	Left Sidecover		1
19	6012091	Screw	M6 x 1.0P x 10Lg	16
20	6012204	Hex Nut	5/16"-18NC	1
21	6012205	Idler Assembly		1
22	6012206	Stand Off		2
23	6012207	Stop Switch		1
24	6012208	Start Switch		1
25	6012209	Ball Detent	6mm	1
26	6012210	Spring		1
27	6012211A	Shifter Hub		1
28	6012212	Set Screw	M6 x 1.0P x 12Lg	1
29	6012213	Shaft		1
30	6012214	Handle		1
31	6012087	Screw	M5 x 0.8P x 10Lg	4
32	6012088	Cord Clip	ACC-3	4
33	6012156	Socket Head Cap Screw	M10 x 1.5P x 35Lg	14
34	6012215	Right Column		1
35	6012216	Ball Bearing	6004ZZ	1
36	6293370	Key	5 x 5 x 10	1
37	6292745	Key	5 x 5 x 16	1
38	6012217	Shaft		1
39	6012218	Housing		1
40	6012219	Sleeve		1
41	6012220	Socket Head Cap Screw	M6 x 1.0P x 16Lg	2
42	6012221	Rocker Arm		1
43	6012222	Right Cover		1
44	6012223	Handwheel		1
45	6012224	Lock Knob		1
46	6012225	Handwheel Swivel Assembly		1
47	6012226	Label Shifter		1
48	6012227	Rivet		6
49	6012228	Pointer		1
51	6012230	Scale		1
52	6012293	Hex Nut	M20 x 2.5	1
53	6012231	Height Adjust Label		1
54	6012201	Flat Washer	4.3 x 10 x 1T	1
55	6012232	Screw	M4 x 0.7P x 8Lg	1

Table Assembly

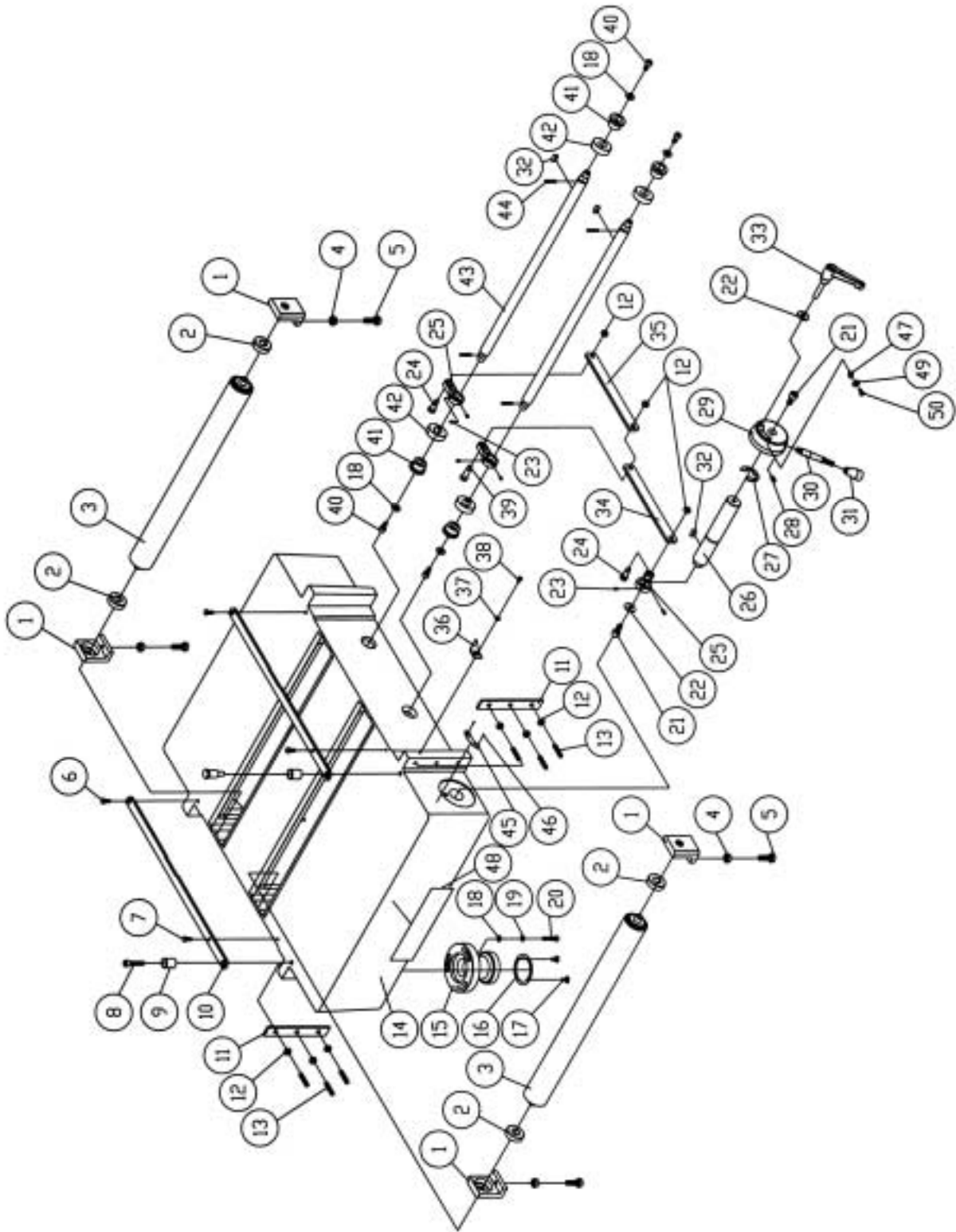

Parts List: Table Assembly

Index No.	Part No.	Description	Size	Qty
1	6012233	Bracket		4
2	BB-6203ZZ	Ball Bearing	6203-ZZ	4
3	6012234	Roller Assembly		2
4	6012079	Hex Nut	M10 x 1.5P	4
5	6012235	Hex Screw	M10 x 1.5P x 30Lg	4
6	6012236	Hex Screw	M8 x 1.25P x 16Lg	2
7	6012237	Hex Screw	M6 x 1.0P x 16Lg	2
8	6012238	Hex Screw	M10 x 1.5P x 50Lg	2
9	6012239	Pointer		2
10	6012240	Plate		2
11	6012241	Plate		2
12	6012097	Hex Nut	M8 x 1.25P	9
13	6012242	Set Screw	M8 x 1.25P x 35Lg	6
14	6012243	Table		1
15	6012244	Table Adjusting Hub		2
16	6012245	Bushing		2
17	6012070	Screw w/Washer	M4 x 0.7P x 8Lg/4mm x 10 x 0.8T	4
18	6012083	Flat Washer	8.5mm x 19 x 2T	10
19	6012067	Spring Washer	8.2mm x 15.4	6
20	6012246	Socket Head Cap Screw	M8 x 1.25P x 40Lg	6
21	6012048	Socket Head Cap Screw	M10 x 1.5P x 20Lg	2
22	6012080	Flat Washer	10mm x 25 x 3T	2
23	6012098	Set Screw	M5 x 0.8P x 5Lg	6
24	6012247	Special Screw		2
25	6012248	Linking Plate		3
26	6012249	Shaft		1
27	6012250	E-Ring	ETW-24	1
28	6012251	Set Screw	M6 x 1.0P x 12Lg	1
29	6012252	Hub		1
30	6012213	Shaft		1
31	6012214	Handle		1
32	6293370	Key	5 x 5 x 10	3
33	6012253	Handle		1
34	6012254	Fixing Plate		1
35	6012255	Fixing Plate		1
36	6012256	Pointer		1
37	6012257	Flat Washer	5.3mm x 12 x 1T	1
38	6012087	Screw	M5 x 0.8P x 10Lg	1
39	6012258	Special Screw		1
40	6012259	Socket Head Cap Screw	M8 x 1.25P x 16Lg	4
41	6012260	Shaft		4
42	6012261	Cam		4
43	6012262	Transfer Rod		2
44	6012263	Spring Pin	5mm x 26L	4
45	6012264	Label		1
46	6012227	Rivet		2
47	6012228	Pointer		1
48	6012265	Name Label		1
49	6012201	Flat Washer	4.3mm x 10 x 1.0T	1
50	6012232	Screw	M4 x 0.7P x 8 Lg	1

Parts List: Top Cover Assembly

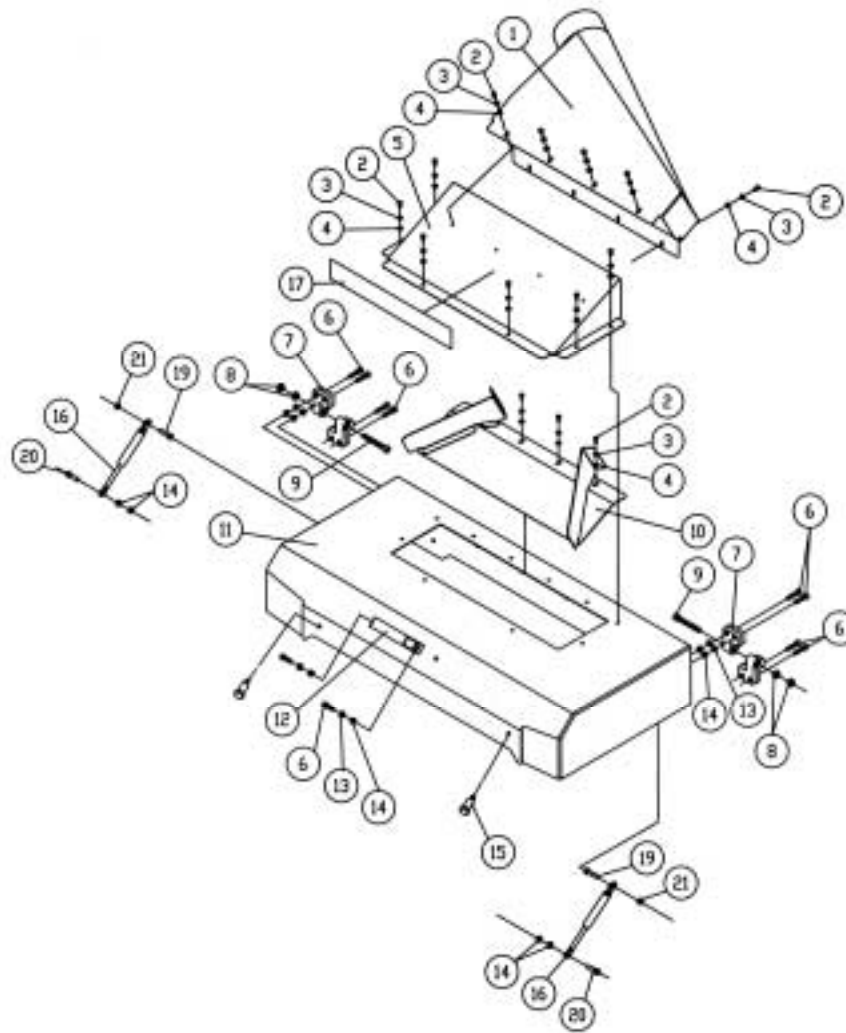

Index No.	Part No.	Description	Size	Qty
1.....	6012181.....	Dust Hood.....		1
2.....	6012091.....	Screw.....	M6 x 1.0P x 10Lg.....	18
3.....	6012182.....	Spring Washer.....	6.1mm x 12.3.....	18
4.....	6012183.....	Flat Washer.....	6.6mm x 13 x 1T.....	18
5.....	6012184.....	Upper Cover.....		1
6.....	6012066.....	Socket Head Cap Screw.....	M8 x 1.25P x 25Lg.....	10
7.....	6012185.....	Cast Hinge Half.....		4
8.....	6012079.....	Nut.....	M10 x 1.5P.....	4
9.....	6012186.....	Socket Head Cap Screw.....	M10 x 1.5P x 60Lg.....	2
10.....	6012187.....	Deflection Plate.....		1
11.....	6012188.....	Top Cover.....		1
12.....	6012189.....	Handle.....		1
13.....	6012067.....	Lock Washer.....	8.2mm x 15.4.....	6
14.....	6012097.....	Hex Nut.....	M8 x 1.25P.....	10
15.....	6012190.....	Special Screw.....		2
16.....	6012191.....	Cylinder.....		2
17.....	6012192.....	Warning Label.....		1
18.....	6012282.....	Screw w/ Washer.....	M6 x 1.0P x 10Lg.....	4
19.....	6012283.....	Shoulder Screw.....		2
20.....	6012284.....	Shoulder Screw.....		2
21.....	6012285.....	Check Nut.....	M8 x 1.25P.....	2

Cutterhead Assembly

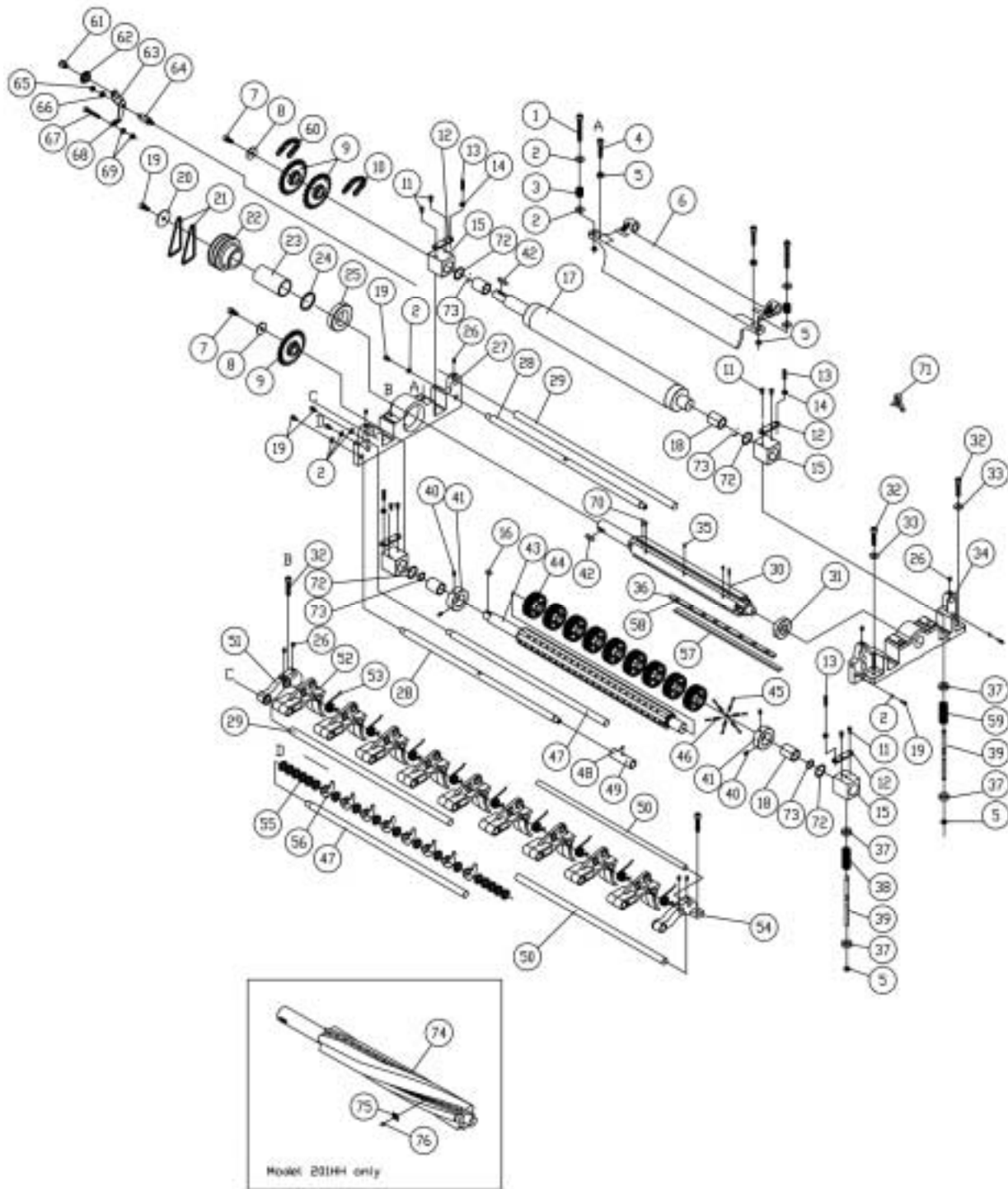

Parts List: Cutterhead Assembly

Index No.	Part No.	Description	Size	Qty
1	6012131	Socket Head Cap Screw	M10 x 1.5P x 75Lg	2
2	6012080	Flat Washer	10mm x 25 x 3T	10
3	6012132	Spring		2
4	6012133	Socket Head Cap Screw	M10 x 1.5P x 50Lg	2
5	6012079	Hex Nut	M10 x 1.5P	8
6	6012134	Pressure Bar Casting		1
7	6012048A	Socket Head Cap Screw (LH Thread)	M10 x 1.5P x 20Lg	2
8	6012135	Washer		2
9	6012136	Sprocket		3
10	6012137	Chain (infeed roller to outfeed roller)	#40 x 60 pcs	1
11	6012138	Socket Head Cap Screw	M6 x 1.0P x 16Lg	8
12	6012139	Plate		4
13	6012140	Set Screw	M8 x 1.25P x 25Lg	4
14	6012097	Hex Nut	M8 x 1.25P	4
15	6012141	Bearing Housing		4
16	6012104	Key	8 x 7 x 18	1
17	6012143	Outfeed Roller		1
18	6012144	Needle Bearing	NA-6906	4
19	6012048	Hex Socket Cap Screw (LH Threads)	M10 x 1.5P x 20Lg	7
20	6012116	Washer		1
21	6012145	Belt	A81	2
22	6012146	Cutterhead Pulley		1
23	6012147	Bushing		1
24	6012148	R-Ring	RTW-85	1
25	6012149	Ball Bearing	6209-2NSE	1
26	6012150	Set Screw	M8 x 1.25P x 10Lg	8
27	6012151	Cutterhead Casting Left		1
28	6012152	Shaft		2
29	6012153	Shaft		2
30	6012154	Cutterhead *		1
31	6012155	Ball Bearing	6007-2NSE	1
32	6012156	Socket Head Cap Screw	M10 x 1.5P x 35Lg	6
33	6012157	Spring Washer	10.2mm x 18.4	4
34	6012158	Cutterhead Casting Right		1
35	6012159	Screw *	M5 x 0.8P x 12Lg	12
36	6012160	Knife Gib *		4
37	6012161	Washer		8
38	6012162	Spring		4
39	6012163	Shaft		4
40	6012150	Set Screw	M8 x 1.25P x 10Lg	4
41	6012164	Spacer		2
42	6012165	Key	8 x 7 x 30	1
43	6012166	Infeed Shaft		1
44	6012167	Infeed Roller		22
45	6012168	Shaft		132
46	6012169	Spring		132
47	6012170	Shaft		2
48	6012098	Set Screw	M5 x 0.8P x 5Lg	1
49	6012171	Stock Limiter		1
50	6012172	Shaft		2
51	6012173	Bracket, Left Hand		1
52	6012174	Sectional Chipbreaker		10
53	6012175	Spring		10
54	6012176	Bracket, Right Hand		1
55	6012177	Spacer		72
56	6012178	Anti-Kickback Finger		62
57	6012179	Knife (set of 4) *		1

58.....	6012180.....	Gib Screw *	32
59.....	6012273.....	Spring	2
60.....	6012274.....	Chain (gearbox to outfeed roller).....#40 x 72 pcs.....	1
61.....	6012275.....	Shaft.....	1
62.....	6012276.....	Idle Sprocket.....	1
63.....	6012277.....	Bracket.....	1
64.....	6012278.....	Shaft.....	1
65.....	6012279.....	Check Nut.....M8 x 1.25P.....	1
66.....	6012083.....	Flat Washer.....8.5mm x 19 x 2T.....	1
67.....	6012280.....	Socket Head Cap Screw.....M8 x 1.25P x 50Lg.....	1
68.....	6012281.....	Spring.....	1
69.....	6012097.....	Hex Nut.....M8 x 1.25P.....	2
70.....	6012296.....	Spring *.....	8
71.....	201-KGA.....	Knife Setting Gauge Assembly (index #71-1 thru #71-3) (not shown)*.....	1
71-1.....	6012295.....	Knife Setting Gauge (not shown) *.....	2
71-2.....	6284833.....	Shaft (not shown) *.....	1
71-3.....	6284834.....	E-Ring (not shown) *.....	4
72.....	201-672.....	Retainer Ring.....	4
73.....	201-673.....	Retainer Ring.....	4
.....	1791225.....	Helical Cutterhead Assembly (index #74 thru #76) **.....	1
74.....	201HH-674.....	Helical Cutterhead **.....	1
75.....	1791212.....	Knife Insert (sold in set of 10) **.....	150 total
76.....	JWP208HH-111.....	Knife Insert Screw **.....#10-32 x 1/2".....	150
77.....	JJ6HH-113.....	Star Point Screwdriver (not shown)**.....	2

* Index # 30, 35, 36, 57, 58, 70, 71 are used only with the straight cutterhead on Model 201.

** Index # 74, 75, 76, 77 are used only with the helical cutterhead on Model 201HH.

Electrical Connections – 1 Phase, 230 Volt

