

Parts List: 31A Stand Assembly (3PH)

Index No.	Part No.	Description	Size	Qty
1	31A-78-3	Stand (3PH)		1
2	31A-79	Dust Outlet		1
3	31A-80	Motor Pulley		1
4	31A-103	Motor	2HP, 3PH, 230/460V	1
5	31A-82	Door		1
6	31A-83	Door Latch Assembly		1
7	31A-84	Motor Mounting Bracket		1
8	31A-PBA	Power Box Assembly		1
	31A-208-1	Power Box		1
	31A-208-2	Strain Relief	PGA13.5	2
9	TS-1533042	Phillips Pan Head Machine Screw	M5 x 12	3
10	6292880	Star Washer (External)	M5	1
11	31A-91	Pan Head Screw	M5 x 8	1
13	31A-213-1	Switch Plate		1
14	JC3-119	Hex Flange Bolt	M8 x 12	2
15	TS-1532042	Phillips Pan Head Machine Screw	M4 x 12	2
16	31A-MSA-1	Magnetic Switch Assembly	2HP 3PH 230V	1
	31A-MSA-2	Magnetic Switch Assembly (optional)	2HP 3PH 460V	1
	31A-16-1	Power Cord	3PH	1
	31A-16-2	Motor Cord	3PH	1
	31A-16-3	Strain Relief	PG25A-16B	2
	31A-16-4	Magnetic Switch		1
17	31A-219	Hex Head Screw	M10 x 160	1
18	TS-1551061	Lock Washer	M8	4
19	31A-223	Hex Head Screw	M8 x 20	4
20	31A-95	Hex Head Screw	M8 x 25	4
21	TS-1551061	Lock Washer	M8	4
22	TS-1550061	Flat Washer	M8	12
23	TS-1540061	Hex Nut	M8	4
24	31A-99	Hex Nut	M10	1
25	31A-21	Pan Head Screw w/ Flange	M6 x 12	4
26	TS-1523041	Socket Set Screw	M6 x 12	1
27	31A-100	Pan Head Screw	M4 x 5	2
28	31A-101	Spacer Washer		2
29	31A-99	Hex Nut	M10	2
30	TS-1550071	Flat Washer	M10	2
31	150527	Sponge		2
32	31A-102	Warning Label (not shown)		1
33	6823013	Black Stripe (not shown)		per ft.
34	3312341	Powermatic Label (not shown)		1

Parts List: 31A Sander Body Assembly

Index No.	Part No.	Description	Size	Qty
1	31A-1	Cast Base		1
2	31A-2	Dust Chute (Disc)		1
3	31A-3	Sanding Disc		1
4	31A-4	Disc Table		1
5	31A-5	Trunnion		2
6	31A-6	90° Stop Bracket		1
7	31A-7	Trunnion Holder		2
8	31A-8	Set Screw	M10 x 55	2
9	31A-9	Lock Knob	M10 x 57	1
10	31A-10	Ring Spanner		2
11	31A-11	Sanding Belt Guard		1
12	31A-12	Idler Bearing Housing		1
13	31A-13	Shaft		1
14	31A-14	Key	6 x 6 x 25	2
15	BB-6204ZZ	Bearing	6204ZZ	2
16	31A-16	Aluminum Drum		2
17	31A-17	Hex Nut (L.H. Threads)	M16 x 2	1
18	31A-18	Knob		1
19	31A-19	Index Pin		1
20	31A-20	Knob	M6 x 12	3
21	31A-21	Pan Head Screw w/ Flange	M6 x 12	3
22	31A-22	Locking Handle	M10 x 1.25P	1
23	31A-23	Lock Handle	M10 x 45	1
24	31A-24	Side Plate Casting		1
25	31A-25	Rocker Arm		1
26	31A-26	Hex Head Bolt		1
27	31A-27	Platen		1
28	31A-28	Side Cover		1
29	BB-6205ZZ	Bearing	6205ZZ	2
30	31A-30	Pan Head Screw w/ Flange	M5 x 8	1
31	31A-31	Bearing Housing		1
32	TS-1551061	Lock Washer	M8	3
33	TS-1504051	Socket Head Cap Screw	M8 x 25	3
34	31A-32	Key	6 x 6 x 40	1
35	31A-33	Shaft		1
36	31A-34	Special Washer		2
37	31A-35	Pulley		1
38	31A-36	Belt Guard		1
39	31A-37	Guard		1
40	TS-1550041	Flat Washer	M6	4
41	TS-1551041	Lock Washer	M6	6
42	31A-38	Hex Head Bolt	M6 x 12	2
43	31A-39	Hex Head Bolt	M6 x 20	2
44	TS-1551041	Lock Washer	M6	2
45	31A-40	Work Stop		1
46	31A-41	Pivot Plate		1
47	31A-42	Fence Table		1
48	31A-43	Fence End Bracket		2
49	31A-44	Fence Base		1
50	31A-45	Long Link		1
51	31A-46	Short Link		1
52	31A-47	Socket Head Button Screw	M6 x 12	4
53	31A-48	Hex Head Bolt		3
54	31A-49	Set Screw	M8 x 35	1
55	TS-1540061	Hex Nut	M8	2
56	31A-50	Spring Pin	6mm dia x 20	1
57	31A-51	Set Screw	M6 x 8	1

58	31A-52	Lock Washer	M16	2
59	31A-53	Hex Head Flange Bolt	M6 x 20	4
60	31A-54	Lock Washer	M6	2
61	31A-55	Hex Head Bolt	M6 x 8	2
62	TS-1504041	Socket Head Cap Screw	M8 x 20	2
63	TS-2361081	Lock Washer	M8	2
64	31A-56	Hex Nut (L.H. Threads)	M16 x 2	1
65	31A-57	Socket Head Flat Screw	M6 x 16	1
66	31A-58	Socket Head Flat Screw	M8 x 20	2
67	31A-59	Spring		1
68	31A-60	Pin	6mm dia x 16	2
69	TS-1550071	Flat Washer	M10 x 20	2
70	TS-1505031	Socket Head Cap Screw	M10 x 25	2
71	31A-61	Roll Pin	6mm dia x 24	2
72	31A-62	Roll Pin	6mm dia x 45	4
73	VB-A50	V-belt	A50	1
74	31A-64	Roll Pin	5mm dia x 30	1
75	31A-65	Stop Block		1
76		Sanding Belt (<i>local purchase</i>)	12" dia	1
77		Sanding Disc (<i>local purchase</i>)	6" x 48"	1
78	31A-68	Lock Knob	8mm x 20	1
79	31A-69	Flat Washer	M8 x 30 dia	1
80	31A-70	Lock Knob	M10 x 1.25P	1
81	31A-71	Tilting Scale		1
82	31A-72	Rivet	2mm dia. x 5	2
83	31A-73	Pan Head Screw	M6 x 8	1
84	31A-74	Pointer		1
85	TS-1550041	Flat Washer	M6	1
86	TS-1550071	Flat Washer	M10	2
87	TS-1540041	Hex Nut	M6	1
88	TS-1523071	Socket Set Screw	M6 x 25	1
89	TS-1550031	Flat Washer	M5	1
90	TS-1503051	Socket Head Cap Screw	M6 x 20	2
91	TS-1524051	Socket Set Screw	M8 x 20	1
92	31A-75	Hex Head Bolt	M6 x 25	1
93	TS-1540041	Hex Nut	M6	1
94	31A-76	Pin		1
95	31A-77	Miter Gauge Assembly		1

31A Sander Body Assembly

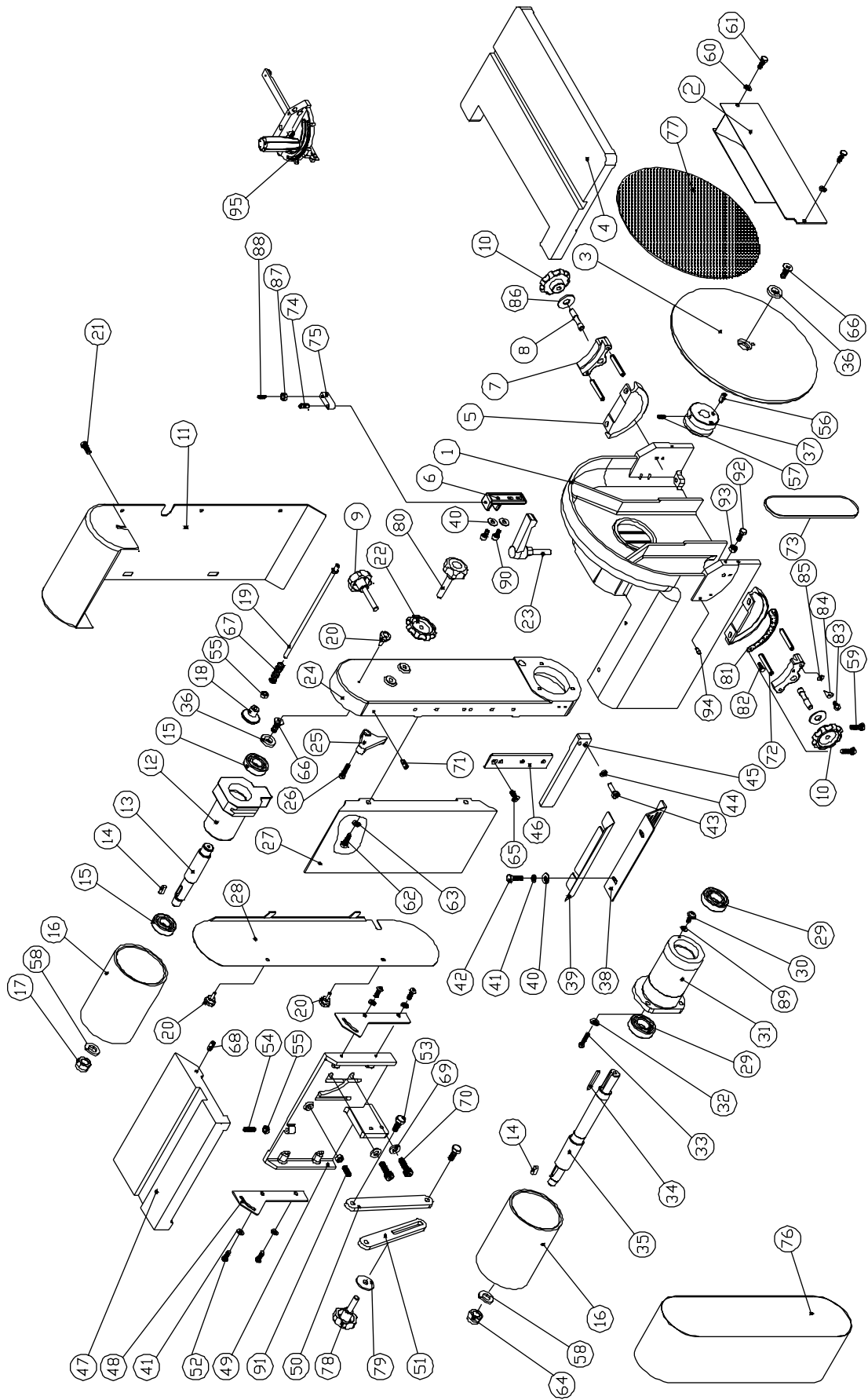

Electrical Connections (3 Phase)

3 Phase 230V

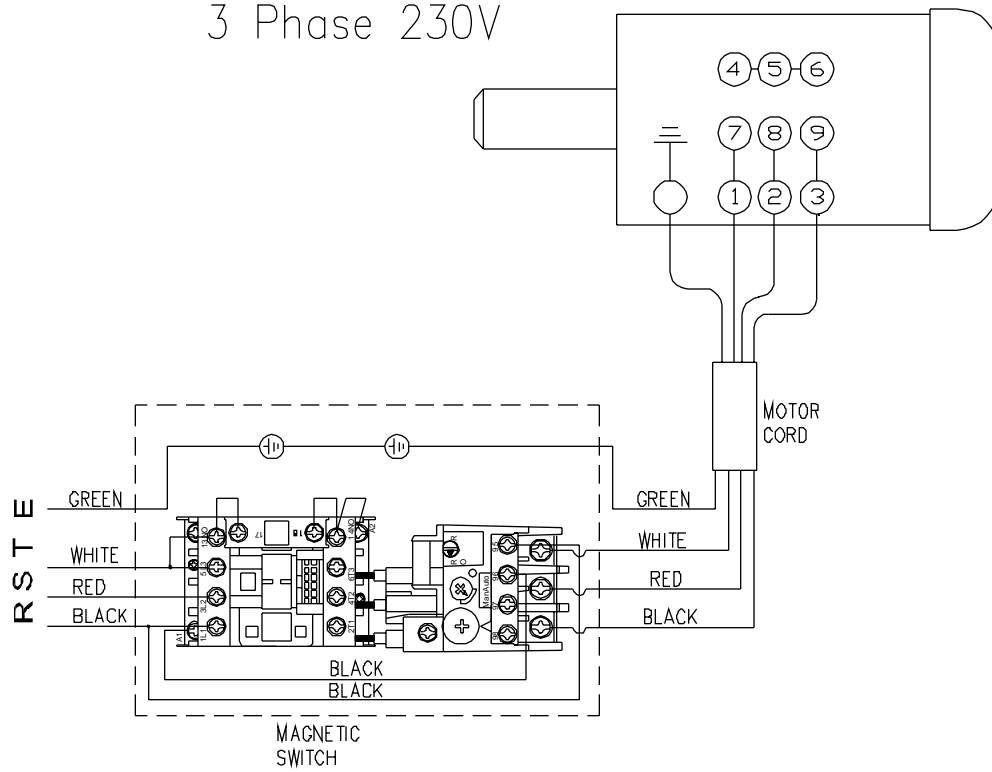

3 Phase 460V

