

# Parts List

Index No.	Part No.	Description	Size	Qty
1.....	701-101	Base.....		1
2.....	701-102	Shaft Cap.....		1
3.....	701-103	T- Nut.....		2
4.....	701-104	Hex Cap Screw (Special).....		2
5.....	701-105	Slide Plate.....		2
6.....	701-106	Bushing.....		2
7.....	701-107	Knob.....		2
8.....	701-108	Roller.....		2
9.....	TS-1550061	Flat Washer.....	M8.....	2
10.....	TS-1503041	Socket Head Cap Screw.....	M6x16.....	4
11.....	701-111	Bar.....		1
12.....	701-112	Rack.....		1
13.....	TS-2245122	Button Head Socket Screw.....	M5x12.....	2
14.....	701-114	Fence.....		1
15.....	TS-1523031	Set Screw.....	M6x10.....	1
16.....	TS-1550061	Flat Washer.....	M8.....	2
17.....	701-117	Bolt.....		2
18.....	701-118	Roll Pin.....	M4x25.....	2
19.....	701-119	Cam Handle.....		2
20.....	701-120	Post.....		1
21.....	701-121	Work Hold-down.....		1
22.....	701-122	Knob.....		1
23.....	701-123	Knob.....		1
24.....	701-124	E-Clip.....	E-12.....	2
25.....	701-125	Gear.....		1
26.....	701-126	Shaft.....		1
27.....	701-127	Key.....	5x5x12.....	2
28.....	701-128	Ext. Retaining Ring.....	S-15.....	2
29.....	701-118	Roll Pin.....	M4x25.....	2
30.....	701-130	Knob.....		2
31.....	701-131	Depth Stop.....		1
32.....	TS-1550061	Flat Washer.....	M8.....	5
33.....	701-133	Locking Handle.....		1
34.....	TS-1551061	Lock Washer.....	M8.....	4
35.....	TS-1504061	Socket Head Cap Screw.....	M8x30.....	4
36.....	701-136	Column.....		1
37.....	TS-1523021	Set Screw.....	M6x8.....	1
38.....	TS-1502031	Socket Head Cap Screw.....	M5x12.....	2
39.....	701-139	Tool Tray.....		1
40.....	701-140	Roll Pin.....	M6x20.....	1
41.....	701-141	Rack.....		1
42.....	TS-1551041	Lock Washer.....	M6.....	7
43.....	701-143	Cylinder Head.....		2
44.....	701-144	Upper Cylinder Fitting.....		1
44-1.....	701-144A	Lower Cylinder Fitting.....		1
45.....	701-145	E-Clip.....	E-7.....	2
46.....	701-146	Knob.....		1
47.....	TS-1550041	Flat Washer.....	M6.....	1
48.....	23011063	Spring.....		1
49.....	701-149	Handle Hub.....		1
50.....	701-150	Gib.....		1
51.....	TS-1523071	Set Screw.....	M6x25.....	3
52.....	TS-1540041	Hex Nut.....	M6.....	3
53.....	701-153	Handle.....		1
54.....	701-154	Lock Handle.....		1
55.....	701-155	Handle Grip.....		1

Index No.	Part No.	Description	Size	Qty
56	701-156	Head		1
57	TS-1503051	Socket Head Cap Screw	M6x20	3
58	701-158A	Gear		1
59	701-159	Collar		1
60	TS-1523011	Set Screw	M6x6	1
61	701-161	Pinion Shaft		1
62	701-162	Chuck Access Cover		1
63	TS-2246122	Button Head Socket Screw	M6x12	2
64	701-164	Motor	3/4 HP, 1Ph, 115/230V	1
	701-164A	Fan (not shown)		1
	701-164B	Fan Cover (not shown)		1
	701-164C	Starting Capacitor (not shown)	200MFD 125VAC	1
	701-164D	Running Capacitor (not shown)	30µF 250VAC	1
65	701-165	Switch Box		1
66	TS-081C052	Pan Head Screw	#10-24x3/4"	2
67	701-167	Strain Relief		1
68	701-168	Power Cord		1
69	701-169	On/Off Switch		1
70	701-170	Chuck	1/2"	1
71	6294204	Chuck Key		1
72	701-172	Locking Handle		1
73	701-173	Bushing Spacer		2
74	701-174	Wave Washer	M5	1
75	TS-1502051	Socket Head Cap Screw	M5x20	1
76	701-176	Bushing	I.D. 5/8"	1
77	701-177	Bushing	I.D. 3/4"	1
78	701-178	Cylinder		1
	701-178A	Cylinder Assembly (#43, #78)		1
79	23011020	Chuck Extension Adapter		1
80	701-180	Chisel Sharpening Cone		1
81	701-181	Ext. Retaining Ring	S-20	1

# Assembly Drawing

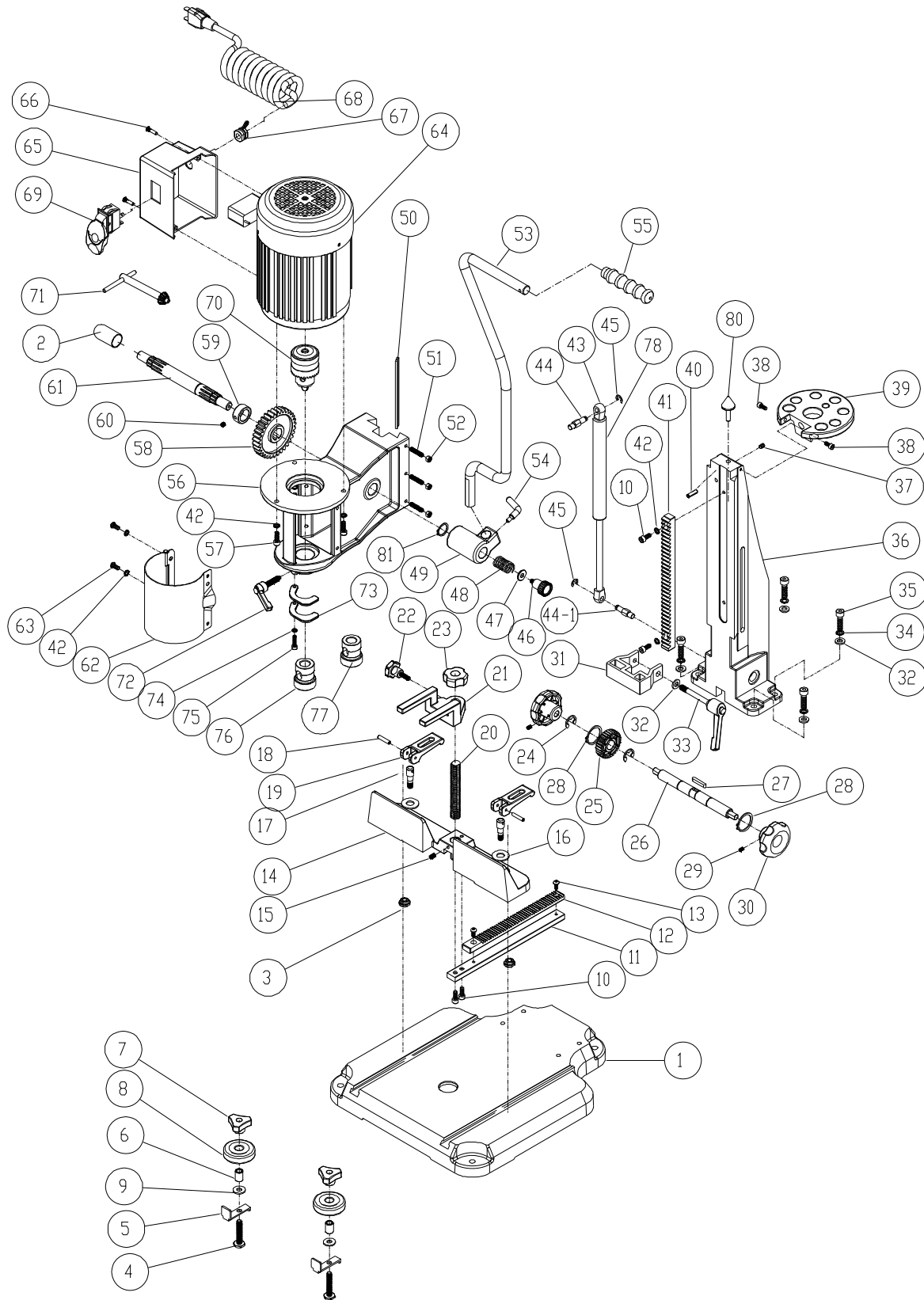

# Wiring Diagram

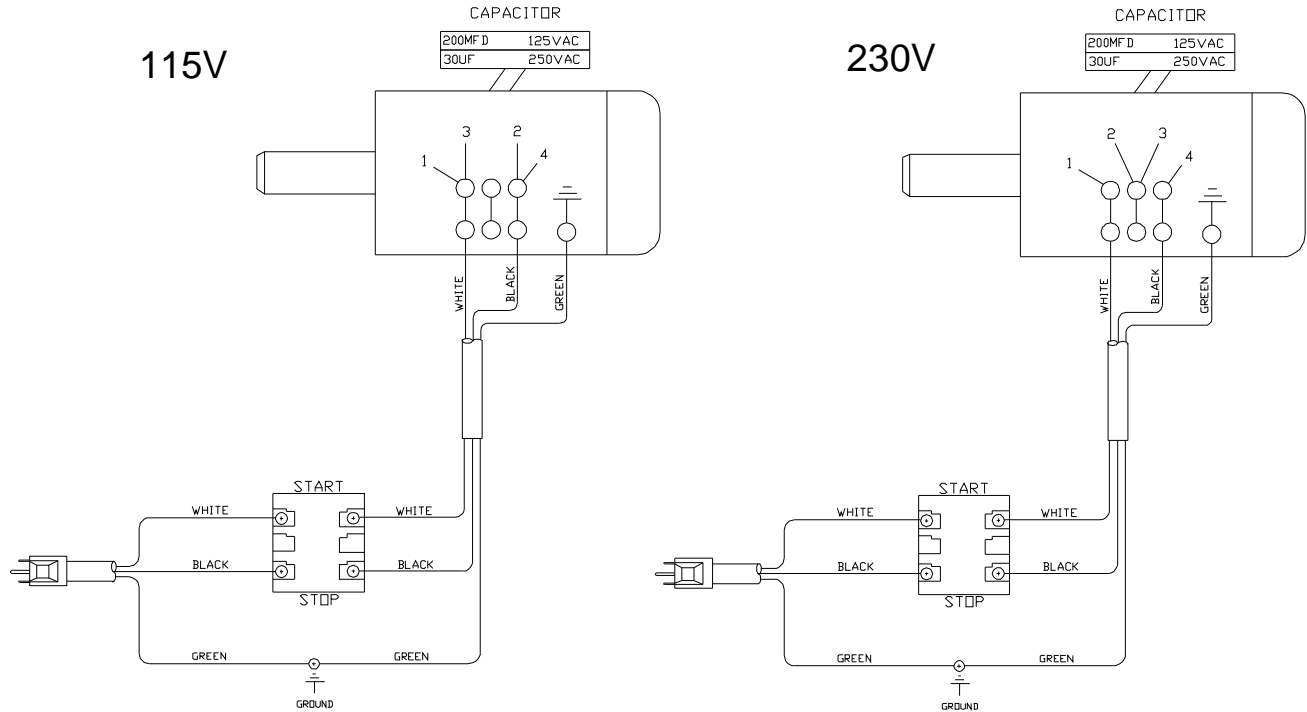

## Optional Accessories

Optional accessories can be purchased by calling the service department at the number below.

1791311      701S Stand  
1791312      701-RB Riser Block Kit

## Ordering Replacement Parts

To order replacement parts or reach our service department, call 1-800-274-6848, Monday through Friday (see our website for business hours, [www.powermatic.com](http://www.powermatic.com)). Having the Model Number and Serial Number of your machine available when you call will allow us to serve you quickly and accurately.



**WALTER MEIER (Manufacturing) Inc.**  
427 New Sanford Road  
LaVergne, Tennessee 37086  
Phone: 800-274-6848  
[www.powermatic.com](http://www.powermatic.com)  
[www.waltermeier.com](http://www.waltermeier.com)