

. - F 012 330 501 - 3305

Item	Part Number	Description	Illustration	Price	Quantity	Price Group
40	2 610 958 880	Washer	1	-,-	1	-
42	2 610 958 881	Washer	1	-,-	1	-
43	2 610 958 882	Nut	1	-,-	1	-
57	2 610 958 883	Pointer	1	-,-	1	-
67	2 610 958 884	Nut	1	-,-	1	-
68	2 610 958 885	Handle	1	-,-	1	-
69	2 610 958 886	Bolt	1	-,-	1	-
89	2 610 004 731	Control Knob	1	-,-	1	-
91	2 610 958 887	Insert	1	-,-	1	-
111	2 610 958 888	Switch	1	-,-	1	-
132	2 610 958 890	Power supply cord	1	-,-	1	-
146	2 610 012 922	Supporting foot	1	-,-	4	-
155	2 610 958 891	Bolt	1	-,-	1	-
156	2 610 958 892	Locking Washer	1	-,-	1	-
157	2 610 958 893	Plain Washer	1	-,-	1	-
181	2 610 958 894	Insert	1	-,-	1	-
182	2 610 958 895	Belt Pusher	1	-,-	1	-
183	2 610 958 896	Assembly Wrench	1	-,-	1	-
184	2 610 958 792	Assembly Wrench	1	-,-	1	-
198	2 610 013 323	Support bracket	1	-,-	2	-
199	2 610 013 321	Support bracket	1	-,-	4	-
200	2 610 013 322	Support bracket	1	-,-	2	-
201	2 610 013 325	Support bracket	1	-,-	2	-
202	2 610 013 324	Support bracket	1	-,-	2	-
806	2 610 958 903	Carbon-Brush Set	1	-,-	1	-
840	2 610 958 898	Guide	1	-,-	1	-
844	2 610 958 899	Protection	1	-,-	1	-
877	2 610 958 897	Guide	1	-,-	1	-
885	2 610 958 902	Hardware package	1	-,-	1	-
888	2 610 958 901	Hardware package	1	-,-	1	-
890	2 610 958 900	Stand Foot	1	-,-	1	-

Illustration - Type E

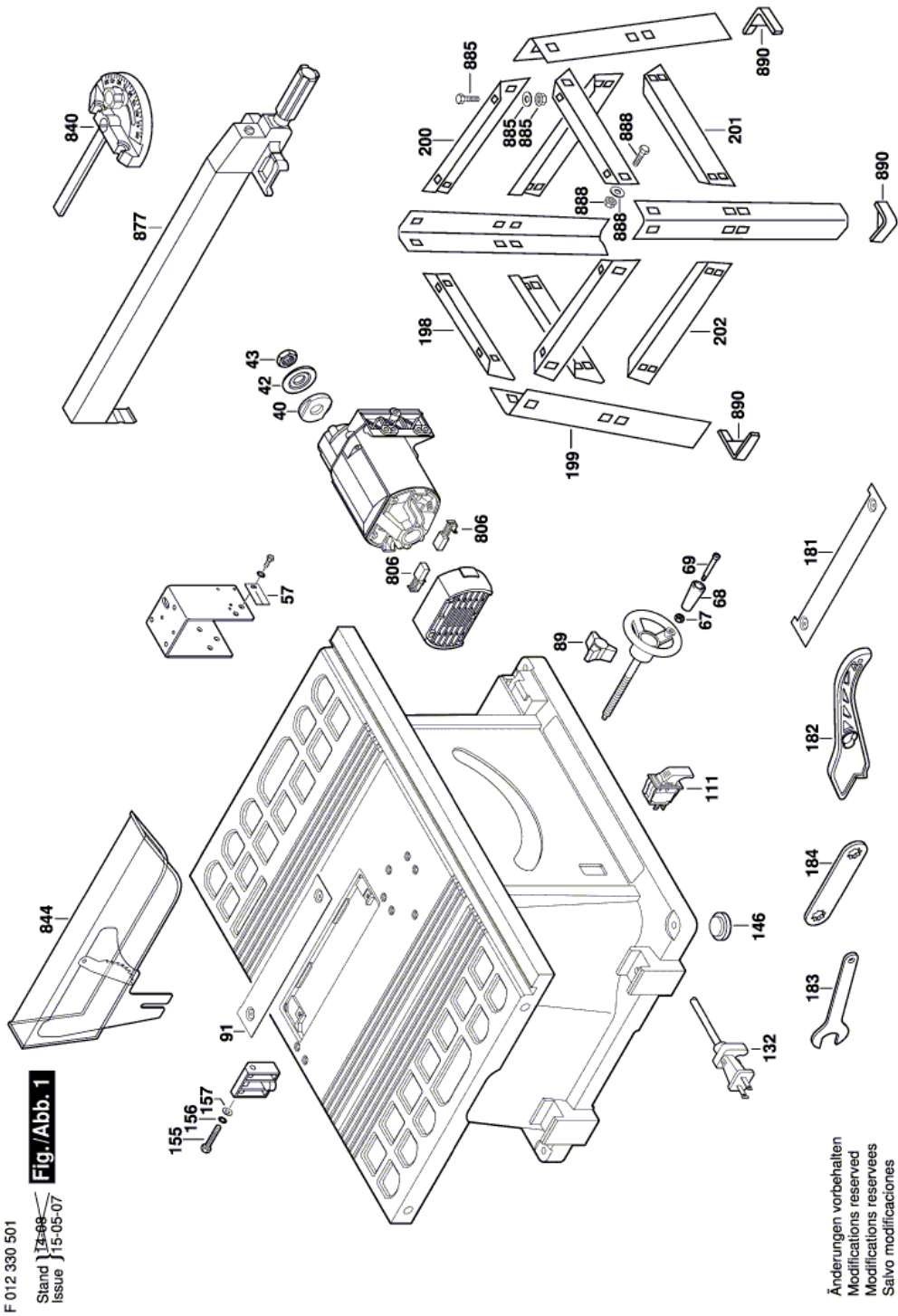

F 012 330 501

Stand 13-08
Issue 15-05-07

Fig./Abb. 1

Information subject to change without further notice.