

# PARTS LEGEND

S200-S16, 501230

1	501043	1	T.H.S.C.S. 1/4-20 x 1/2"	44	026133	2	Roll Pin 1/8 x 1
2	500956	1	Cap Diffuser	45	401958	1	Valve Body
3	091362	4	S.H.C.S. 1/4-20 x 1-1/2"	46	402668	2	Retaining Washer
4	092757	4	Flat Washer	47	501008	1	Trigger Lever
5	501231	1	Cap	48	501010	1	Trigger
6	402717	1	Conical Spring	49	501009	1	Roll Pin
* 7	404230	1	Retaining Ring	50	402669	1	Trigger Pin
8	501250	1	Upper Valve Piston	51	092037	4	Locknut
* 9	091542	1	O-Ring	▲ 52	004502	2	S.H.C.S. 10-32 x 5/8"
10	404054	1	Seal, Main Valve	53	402781	1	Rail Bracket
11	404056	1	Lower Valve Piston	▲ 54	004224	3	S.H.C.S.10-32 x 3/8"
* 12	090927	1	O-Ring, Main Valve	55	402743	1	Pin Negator Drum
* 13	092775	1	O-Ring, Main Valve	56	091534	1	Drum, Negator
* 14	092773	1	O-Ring, Main Valve	57	091532	1	Negator
* 15	404256	2	O-Ring	▲ 58	091568	1	Bd. Head Screw 6-32 x 1/4"
16	500954	1	Post, Main Valve	59	402796	1	Follower
17	015660	1	S.H.C.S. 10-24 x 1/2"	60	402797	1	Retaining Bushing
18	403582	1	Driver Blade Nut	61	402798	1	Latch Follower Button
* 19	405430	1	O-Ring, Piston	62	402799	1	Spring Follower Latch
20	501169	1	Piston	63	402740	2	Roll Pin 3/32 x 7/16
* 21	403202	1	Driver Blade	64	402780	1	Pivot Rail Cover Assembly
22	501322	1	Sleeve Retainer	65	501226	1	Nameplate
23	402725	1	Seal Sleeve	66	403427	1	Rail & Rail Cover Assembly
24	405243	1	Flange Sleeve	** 67	500459	1	Warning Label
25	501228	1	Sleeve	68	404698	2	Roll Pin Assembly
* 26	402728	1	O-Ring, Sleeve	69	402730	1	Pivot Pin Front Guide
* 27	091966	1	O-Ring, Sleeve	70	405079	1	Spring Front Guide Latch
* 28	500369	2	O-Ring, Sleeve	71	403206	1	Latch Front Guide
29	501227	1	Bumper Retainer	72	092176	1	Roll Pin 5/32 x 1-3/8"
30	500975	1	Gasket Cap	73	403205	1	Back Plate
31	501140	1	Logo Housing Left	74	404232	2	S.H.C.S. 8-32 x 13/16"
32	501141	1	Logo Housing Right	75	403204	1	Front Guide
33	402708	1	Gasket Nose Flange	76	402734	1	Spring
34	501229	1	Bumper	77	402792	1	Upper W.C.E.
35	402785	1	Seal Driver Blade	78	402629	1	Hardened Washer
36	402706	1	Flange	79	403716	2	S.H.C.S. 10-32 x 5/16"
37	091545	4	S.H.C.S. 1/4-20 x 7/8"	80	403207	1	Lower W.C.E.
38	501023	1	Grip Handle	81	402736	1	Flat Washer
39	500957	1	Housing	82	402738	1	Spring
40	500963	1	End Plug	83	501320	1	Guide Block
41	097748	1	Spring Valve Pin	84	501243	1	Intermediate W.C.E.
42	097746	1	Valve Pin	85	071297	1	Roll Pin 1/8 x 1-1/8"
* 43	092174	1	O-Ring, Valve Body	86	501299	2	S.H.C.S. 1/4-20 x 1"

\* Denotes normal wear items.

\*\* Make sure warning label (500459) is properly affixed. Replace if necessary. Label available at no charge through the Service Dept.

▲ Apply Loctite 242 (Blue)

→ Denotes new change

## Fastener sizes:

Length: 3/4" to 2"

Gauge & Crown: 16 ga. 1/2 Crown

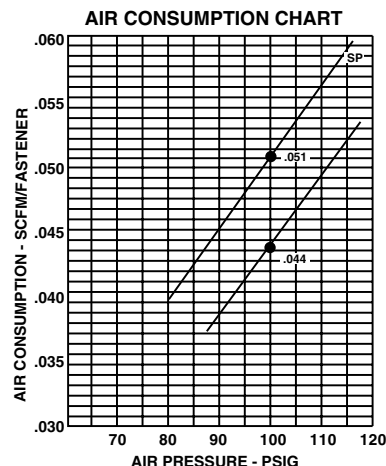

# S200-S16

501230

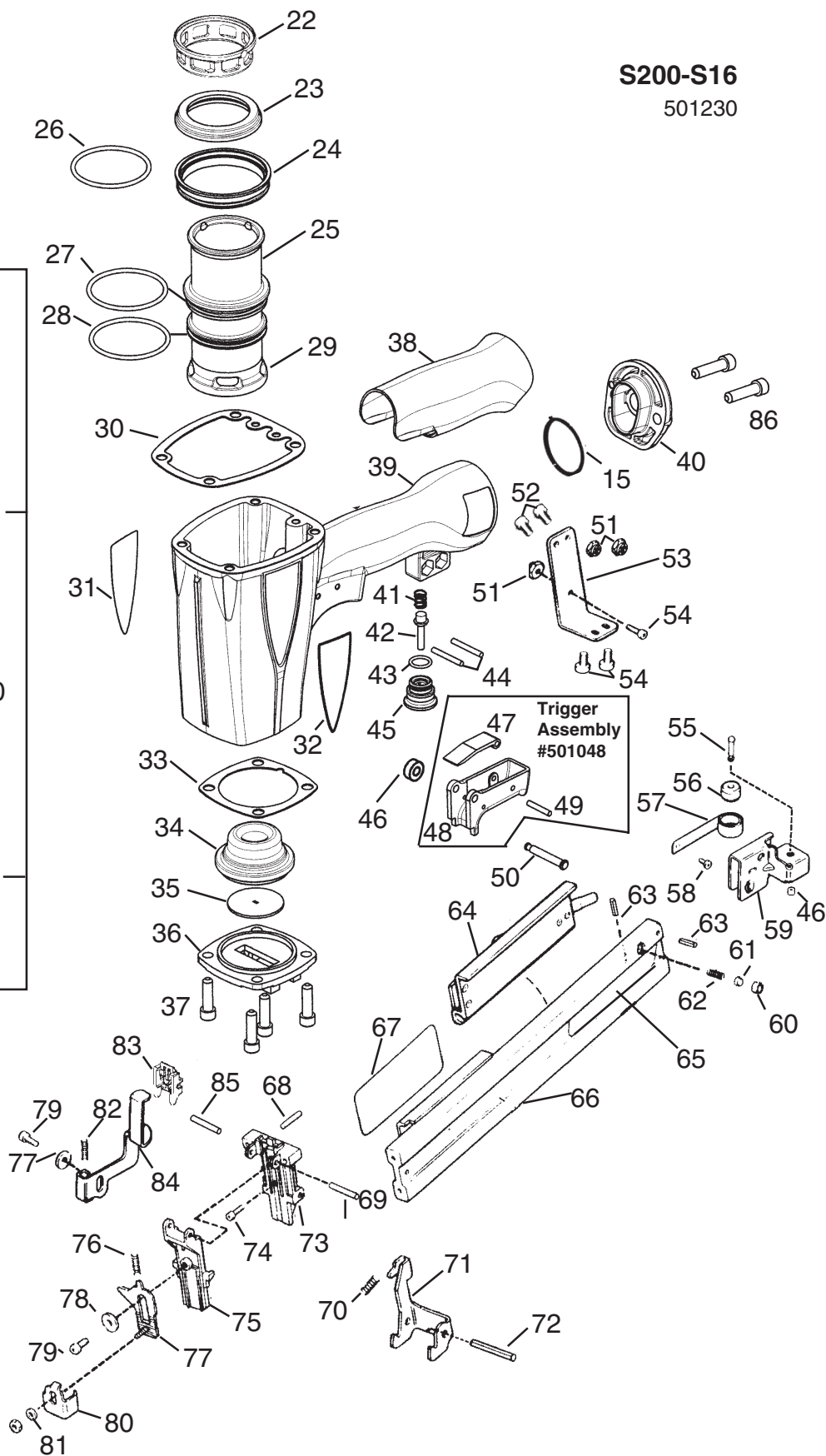
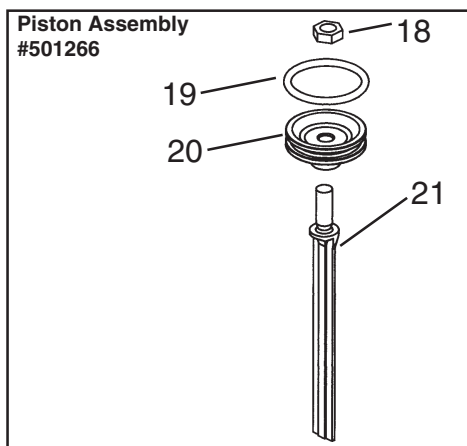
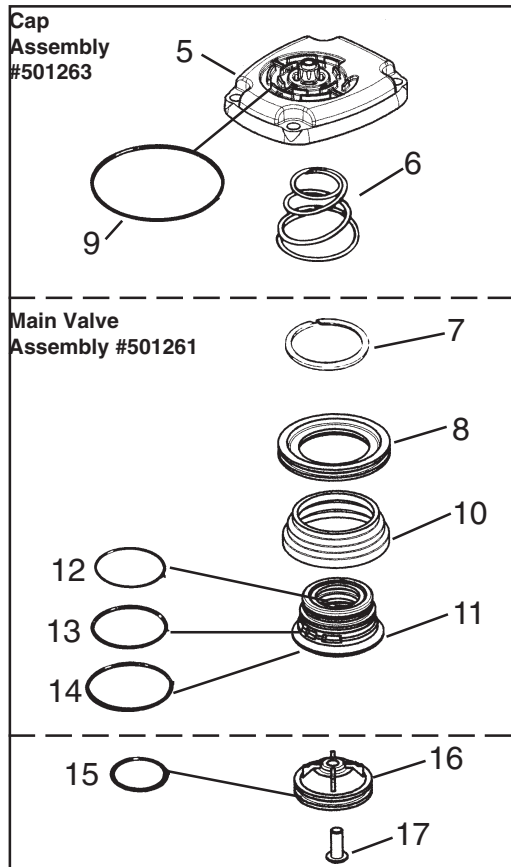
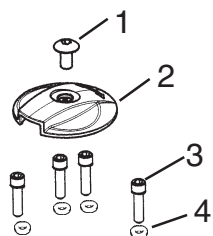

## WARNING

All parts must be periodically inspected and replaced if worn or broken. Failure to do this can affect the tool's operation and present a safety hazard.