



SERVICE PARTS LIST

BULLETIN NO.
54-24-6001

SPECIFY CATALOG NO. AND SERIAL NO. WHEN ORDERING PARTS		REVISED BULLETIN	DATE
3/4" HEX DEMOLITION HAMMER		54-24-6000	Mar. 2013
CATALOG NO.	5337-20	SERIAL NUMBER	A47B
		WIRING INSTRUCTION	58-01-0195

00
0

EXAMPLE:
Component Parts (Small #) Are Included When Ordering The Assembly (Large #).

SEE PAGES 2 AND 3 FOR ADDITIONAL SERVICE NOTES, TORQUE AND LUBRICATION SPECIFICATIONS

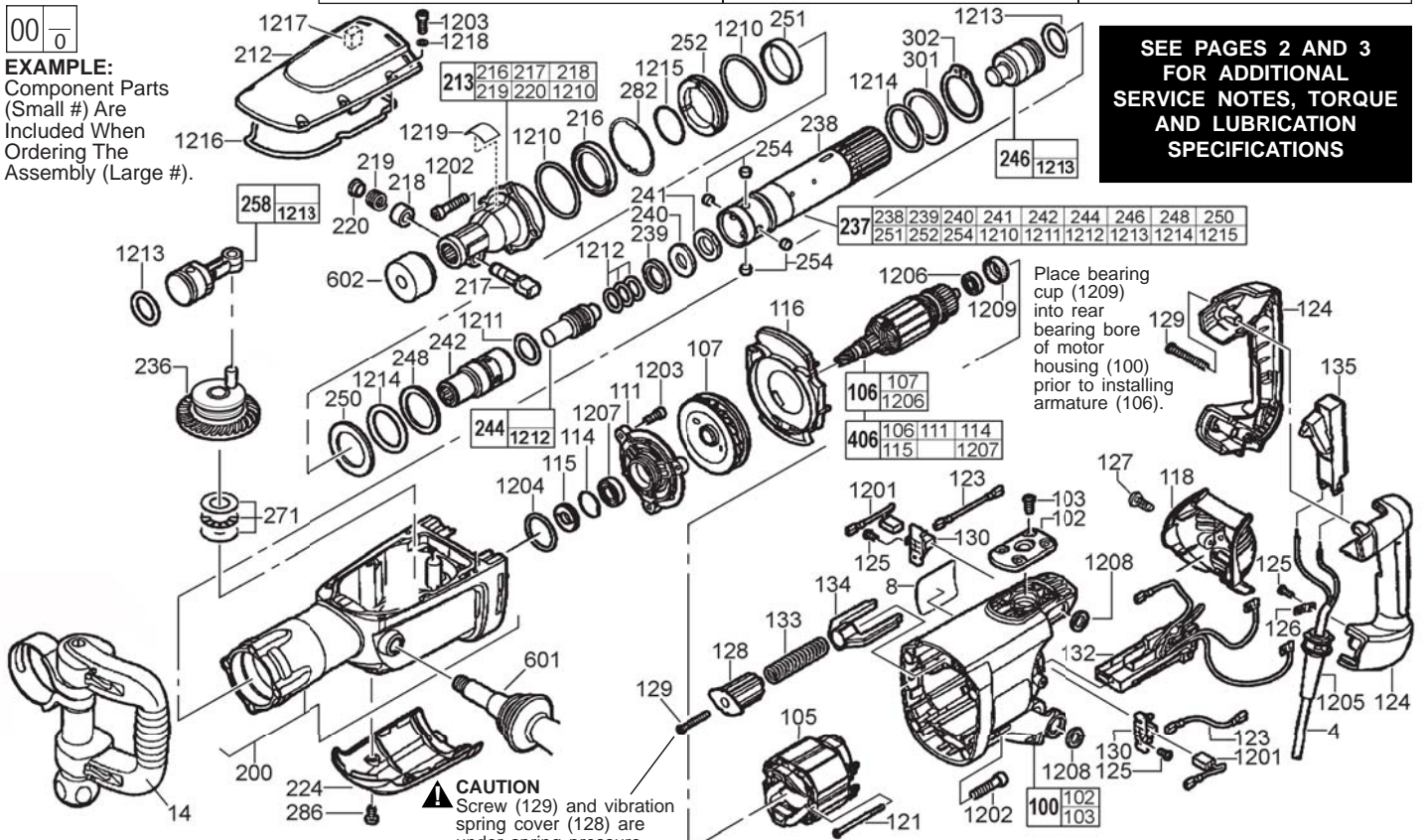

FIG.	PART NO.	DESCRIPTION OF PART	NO. REQ.
4	22-64-0022	CORD SET	1
8	12-20-5337	SERVICE NAMEPLATE KIT	1
14	43-62-0042	SPADE SIDE HANDLE	1
100	31-50-0033	MOTOR HOUSING	1
102	42-92-0106	SIDE HANDLE PLATE	1
103	05-78-0070	SCREW - SIDE HANDLE PLATE	4
105	18-11-0050	FIELD	1
106	16-10-0140	ARMATURE ASSEMBLY	1
107	22-84-0442	FAN	1
111	28-28-0118	BEARING END PLATE	1
114	44-90-0019	RETAINING RING	1
115	44-40-0042	SEAL NUT	1
116	42-14-0105	AIR DEFLECTION RING	1
118	31-15-0051	SERVICING LID	1
121	05-78-0071	SCREW - FIELD	2
123	23-94-0031	WIRE - RED	2
124	31-15-0052	D-HANDLE SET	1
125	05-78-0072	SCREW	4
126	31-17-0110	STRAIN RELIEF CLAMP	1
127	05-78-0073	SCREW - SERVICING LID	2
128	31-15-0053	COVER - VIBRATION SPRING	1
129	05-78-0074	SCREW	5
130	22-20-0027	BRUSH HOLDER	2
132	22-75-0080	DIAL SWITCH	1
133	40-50-0041	SPRING - VIBRATION	1
134	31-10-0130	VIBRATION LEVER	1
135	23-66-0031	SWITCH - LOCK ON	1
200	31-40-0032	GEAR BOX WITH SPINDLE SLEEVE BEARING	1
212	31-15-0061	COVER - UPPER GEAR BOX	1
213	30-60-0030	NOSE PIECE ASSEMBLY	1
216	43-44-0062	SEAL RING	1
217	44-10-0040	LATCH BAR- NOSE PIECE	1
218	43-56-0072	SLEEVE - NOSE PIECE	1
219	40-50-0042	SPRING - NOSE PIECE	1
220	43-56-0073	LATCH - NOSE PIECE	1
224	31-15-0062	COVER - LOWER GEAR BOX	1
236	36-17-0062	CRANK ASSEMBLY	1
237	38-50-0046	SPINDLE ASSEMBLY	1
238	38-50-0044	SPINDLE SLEEVE	1
239	45-88-0052	THRUST COLLAR	1
240	34-40-0061	BACK PRESSURE O-RING	1
241	45-88-0185	WASHER	1

FIG.	PART NO.	DESCRIPTION OF PART	NO. REQ.
242	44-82-0073	STRIKER GUIDE	1
244	45-56-2526	STRIKER	1
246	44-82-0074	RAM	1
248	45-88-0053	ATTACHMENT WASHER (.118 THICK)	1
250	45-88-0054	WASHER (.154 THICK)	1
251	44-96-0132	ROLLER RACE	1
252	44-90-0018	THRUST COLLAR	1
254	44-96-0133	ROLLER	4
258	44-62-0053	PISTON	1
271	02-80-0117	THRUST BEARING WITH WASHERS	1
282	44-90-0016	RETAINING RING	1
286	05-81-0703	SCREW - LOWER GEAR BOX COVER	2
301	45-88-0057	WASHER	1
302	44-90-0021	RETAINING RING	1
406	16-10-0145	ARMATURE ASSEMBLY WITH BEARING END PLATE	1
601	43-62-0043	AUXILIARY SIDE HANDLE	1
602	42-52-0057	DUST GUARD CAP	1
1201	22-16-0026◆	CARBON BRUSH SET (PKG. 2)	2
1202	05-81-0701◆	SCREW M8 x 40	8
1203	05-81-0702◆	SCREW M5 x 16	9
1204	34-40-0062◆	O-RING - GEAR BOX	1
1205	44-76-0051◆	CORD PROTECTOR	1
1206	02-04-0061◆	BALL BEARING	1
1207	02-04-0062◆	BALL BEARING	1
1208	34-40-0063◆	O-RING - MOTOR HOUSING	4
1209	22-72-0200◆	BEARING CUP	1
1210	34-40-0064◆	O-RING	2
1211	34-40-0071◆	O-RING - STRIKER GUIDE	1
1212	34-40-0072◆	O-RING - STRIKER	3
1213	34-40-0073◆	O-RING	2
1214	34-40-0074◆	O-RING - SPINDLE SLEEVE	2
1215	44-90-0017◆	RETAINING RING	1
1216	43-44-0063◆	GASKET - GEAR BOX COVER	1
1217	43-84-0443◆	FELT	1
1218	45-88-0056◆	WASHER - GEAR BOX COVER	6
1219	10-15-0074	WARNING LABEL - CHISEL	1
	48-55-5337	CARRYING CASE (NOT SHOWN)	1

◆=Component of the 14-46-0041 MAINTENANCE SET (NOT SHOWN)

MILWAUKEE ELECTRIC TOOL CORPORATION
13135 W. LISBON RD., BROOKFIELD, WI 53005
Drwg. 1

Service fixture No. **61-10-0012** is required to remove seal nut (115) from armature shaft (106)/ bearing end plate (111). Secure armature, insert pins of service fixture into holes located in seal nut and turn counter clockwise to remove. When reassembling seal nut to bearing plate, tighten to 141 in.-lbs. (16Nm).

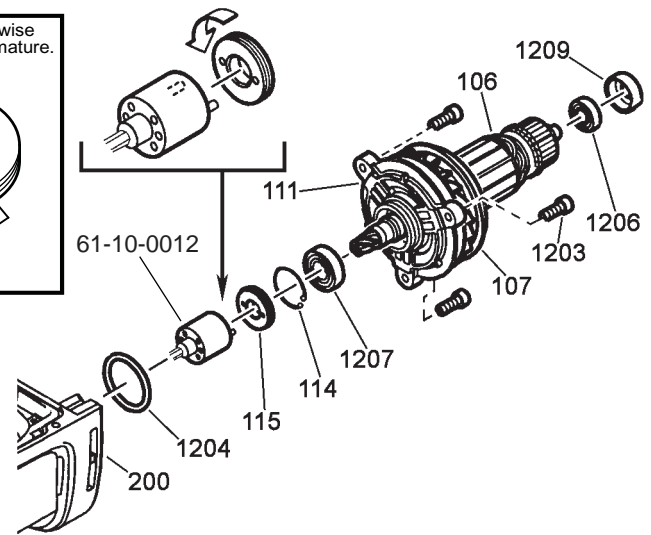
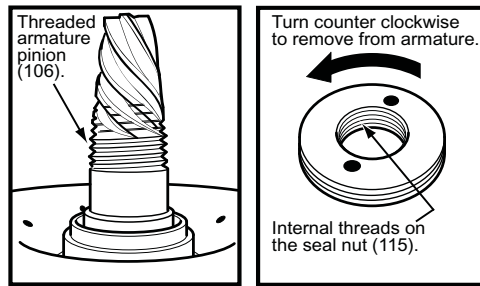

Use forcing disc service fixture No. **61-10-0011** when removing the armature fan (107) from the armature (106).

Press armature fan onto armature shaft to specifications shown. Apply Loctite® 401 Porous Material Bonding Adhesive around the entire base of fan (360°).

SEQUENCE AND TORQUES OF SCREWS			
Callout	Fastener/Part Description	Torque (Nm)	Torque (Lbs-In)
1203	Bearing End Plate Screws	4	35
1203	Upper Gear Box Cover Screws	4.5	40
286	Lower Gear Box Cover Screws	3	27
1202	Nose Piece Screws	18	159
1202	Motor Housing Screws	13	115
127	Servicing Lid Screws	1.3	12
129	D-Handle Screws	3	27
121	Field Screws	2	18
129	Anti-Vibration Mechanism Scr.	3	27
115	Seal Nut	16	141
125	Strain Relief Clamp Screws	1.3	12
125	Carbon Brush Holders	1.3	12
M	Switch Screws	0.5	4
103	Side Handle Plate Screws	4	35

Apply blue Loctite® ThreadLocker 242 adhesive, or the equivalent, to ALL #1202 and #1203 screws prior to reassembly.

When securing upper gear box cover to gear box, tighten the six [6] upper gear box screws in sequence illustrated.

CAUTION
Screw and vibration spring cover are under spring pressure.

Place o-ring (1210) onto the thrust collar (252). Lightly grease the O.D. of the thrust collar. Insert the thrust collar assembly into gear box (200) until the outside face of the thrust collar assembly is flush with the face of the gear box. Place the open end of the service fixture 61-10-0013 over the spindle assembly and gently push the thrust collar assembly into the gearcase prior to installing the retaining ring (282). **Striking the service fixture with a hammer is not recommended, doing so may cause the thrust collar to wedge in the housing.**

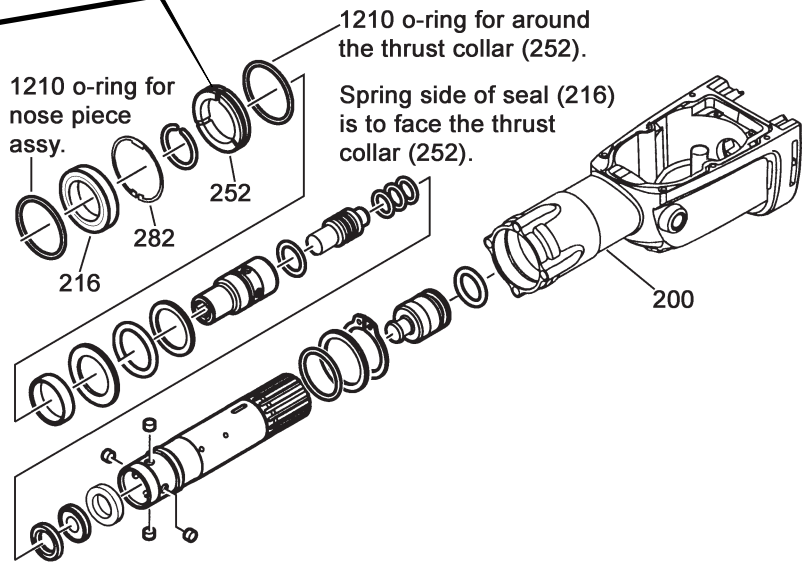
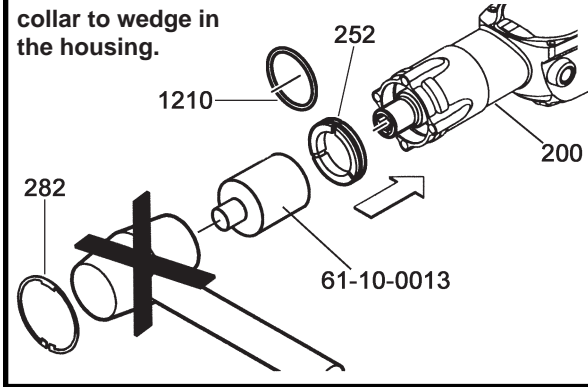

MAINTENANCE KIT CONTAINING "Q"/"Q2" GREASE, FOLLOW THESE INSTRUCTIONS

Lubrication of this tool should be performed at regular intervals or when the carbon brushes switch off at the latest.

After the tool is completely disassembled, remove all of the old grease and replace with the new grease as indicated.

**FOR
5337-20
HAMMERS**

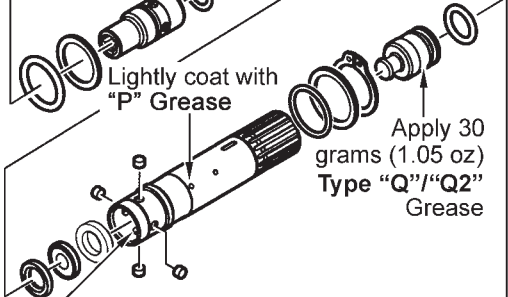
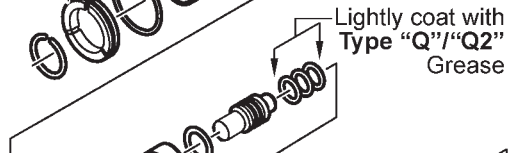
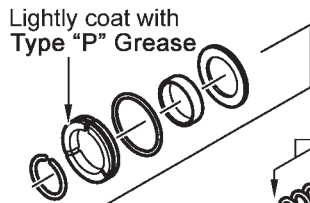

Place 5 grams (.175 oz) Type "Q"/"Q2" Grease

Approximately 190 grams (6.7 oz) of Type "P" Grease and 37 grams (1.32 oz) of Type "Q" or Type "Q2" Grease will be needed in total.

Place 120 grams (4.25 oz) Type "P" Grease

Place 50 grams (1.75 oz) Type "P" Grease

Apply 2 grams (.07 oz) Type "Q"/"Q2" Grease

Apply 20 g (.70 oz) with "P" Grease

Lightly coat with "P" Grease

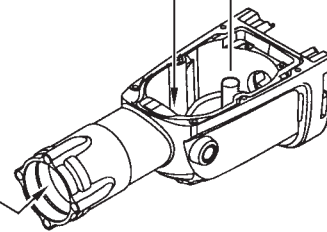

LUBRICATION CHART

LUBRICATION	DESCRIPTION	CATALOG NO.	QTY. REQ.
◆	Type "P" Grease (100 g tube)	49-08-5350	2
◆	Type "Q" Grease (45 g tube)	49-08-4255	1
	OR		
◆	Type "Q2" Grease (45 g tube)	49-08-5345	1
	Hammer Bit Grease (20 g tube)	49-08-5383	1

◆=Component of the 14-46-0041 Maintenance Set. **Note:** Maintenance Set includes either "Q" or "Q2" grease, not both!