



SERVICE PARTS LIST

BULLETIN NO.
54-24-0380

SPECIFY CATALOG NO. AND SERIAL NO. WHEN ORDERING PARTS		REVISED BULLETIN	DATE
1/2" HAMMER-DRILL			Feb. 2009
CATALOG NO.	5387-20	SERIAL NUMBER	A68A
		WIRING INSTRUCTION 58-01-0127	

EXAMPLE:
Component Parts (Small #) Are Included
When Ordering The Assembly (Large #).

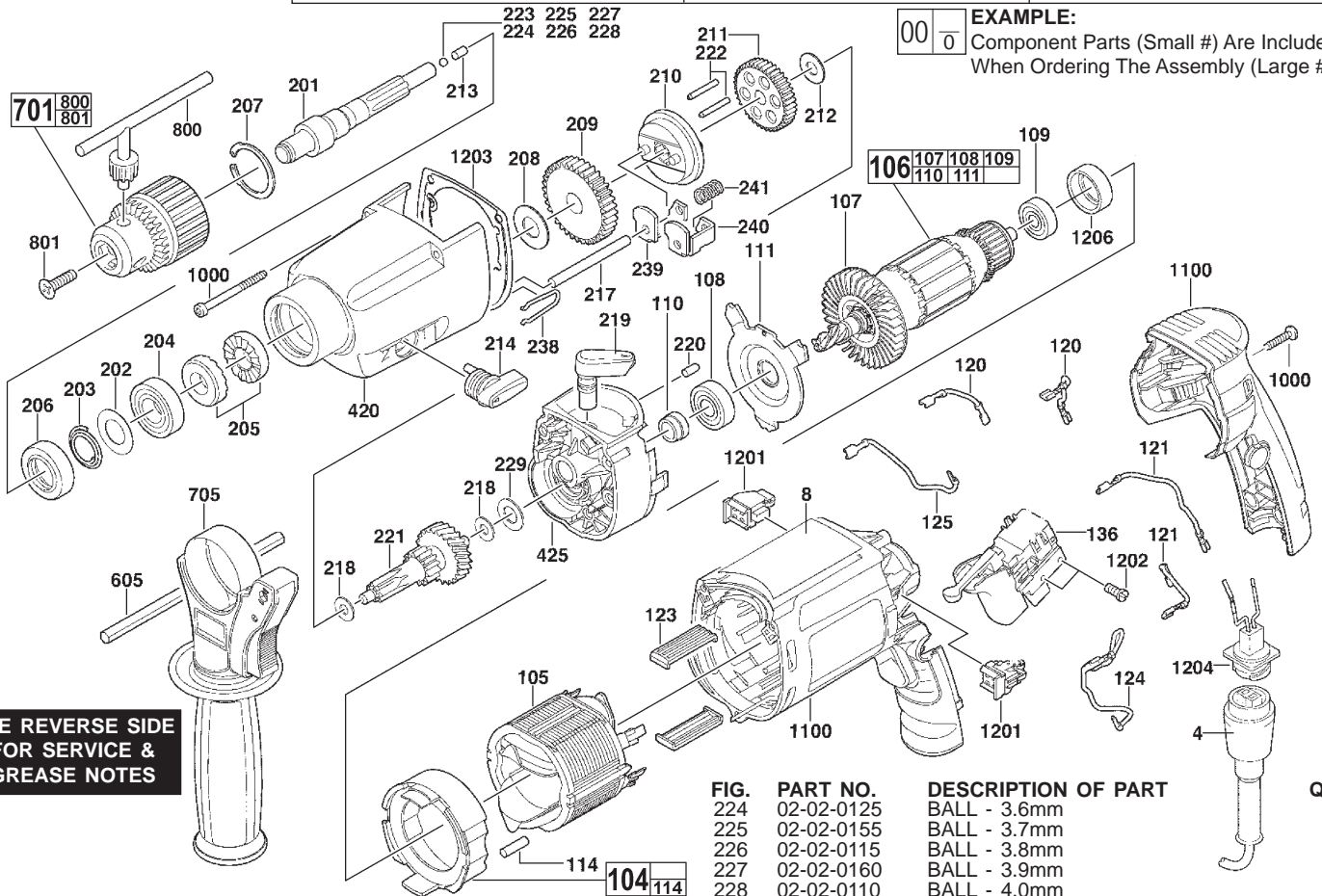

**SEE REVERSE SIDE
FOR SERVICE &
GREASE NOTES**

FIG.	PART NO.	DESCRIPTION OF PART	QTY.
	4	QUIK-LOK CORD SET	1
	8	SERVICE NAMEPLATE	1
	104	AIR DEFLECTION RING	1
	105	FIELD	1
	106	ARMATURE ASSEMBLY	1
	107	FAN	1
	108	BALL BEARING	1
	109	BALL BEARING	1
	110	SLEEVE	1
	111	BEARING COVER	1
	114	VINYL SLUG	4
	120	WIRE ASSEMBLY - BLACK	2
	121	WIRE ASSEMBLY - BLACK	2
	123	FIELD CENTERING CLIP	2
	124	WIRE ASSEMBLY - RED	1
	125	WIRE ASSEMBLY - RED	1
	136	SWITCH	1
	201	SPINDLE	1
	202	WASHER	1
	203	VIBRATION SPRING	1
	204	BALL BEARING	1
	205	RATCHET (SET OF 2)	1
	206	SEAL RING	1
	207	RETAINING RING	1
	208	WASHER	1
	209	SPINDLE GEAR	1
	210	SHIFT RING	1
	211	SPINDLE GEAR	1
	212	WASHER	1
	213	PIN	1
	214	SHIFT LEVER	1
	217	PIN	1
	218	THRUST WASHER	2
	219	SHIFT LEVER	1
	220	PIN	1
	221	REDUCTION GEAR	1
	222	PIN	2
	223	BALL - 3.4mm	1

FIG.	PART NO.	DESCRIPTION OF PART	QTY.
	224	02-02-0125 BALL - 3.6mm	1
	225	02-02-0155 BALL - 3.7mm	1
	226	02-02-0115 BALL - 3.8mm	1
	227	02-02-0160 BALL - 3.9mm	1
	228	02-02-0110 BALL - 4.0mm	1
	229	45-88-0315 WASHER	1
	238	40-50-0150 RETAINING SPRING	1
	239	42-70-0085 SHIFTING CLIP	1
	240	42-70-0090 SHIFTING CLIP	1
	241	40-50-0335 PRESSURE SPRING	1
	420	31-40-0095 GEARCASE	1
	425	28-28-0025 DIAPHRAGM ASSEMBLY	1
	605	43-46-0172 DEPTH GAGE	1
	701	48-66-0087 1/2" CHUCK (INCLUDES #800)	1
		48-66-4040 CHUCK KEY HOLDER (NOT SHOWN)	1
	705	49-15-5300 SIDE HANDLE	1
	800	48-66-3280 CHUCK KEY	1
	801	05-80-0430 6MM LH SCREW	1
	1000	14-46-0030 BOLT KIT (3 BOLTS REQUIRED)	1
	1100	14-38-0145 HOUSING w/BACK HANDLE	1
	1200	14-46-0020 MAINTENANCE SET (NOT SHOWN) (INCLUDES TUBE TYPE 'E' GREASE)	1
	1201	22-16-0065 CARBON BRUSH SET (2 PER PKG)	1
	1202	05-81-0932 SCREW	2
	1203	45-06-0025 SEAL	1
	1204	22-56-0050 BLADE HOUSING ASSEMBLY	1
	1206	45-22-0540 RUBBER SLEEVE	1

FIG. 106,1100,1206 NOTES:
RUBBER SLEEVE (BEARING CUP) TO BE PLACED INTO MOTOR HOUSING ASSEMBLY PRIOR TO INSTALLING ARMATURE ASSEMBLY.

111,220 DEMPLE IN BEARING COVER TO FACE PIN.

209,210 FLATS OF SHIFT RING TO FACE SPINDLE GEAR.

223-228 THE CORRECT SIZE BALL MUST BE CHOSEN TO PROPERLY SHIM OUT THE END PLAY IN THE SPINDLE. SPINDLE IS TO HAVE A SMALL AMOUNT OF END PLAY WITHOUT BEING TIGHT.

5387-20 SERVICE AND GREASE NOTES

Greasing Instructions

Type "E" Grease, No. 49-08-4122 (Included in Maintenance Set No. 14-46-0020)

Type "U" Grease, No. 49-08-0150

1. Clean ratchets faces (205) completely and apply a light coat of type "U" grease, No. 49-08-0150.
2. Place 1/16 oz. of type "E" grease, No. 49-08-4122, in and around the ratchet cavity of the gearcase (420). Other than the mating faces, lightly coat the ratchets (205) with Type "E" Grease, No. 49-08-4122.
3. Coat spindle splines (201), pin (213) and ball (223-228) with 1/16 oz. of type "E" grease, No. 49-08-4122.
4. Place 1/8 oz. of type "E" grease, No. 49-08-4122, in gear cavity of diaphragm (425).
5. Grease gear assembly (parts 208, 209, 210, 211, 212, 217, 218, 221, 222, 229, 239, 240 and 241) using 5/8 oz. type "E" grease, No. 49-08-4122.
6. Using type "E" grease, No. 49-08-4122, lightly grease O-ring on Item (219) before assembly to gearcase.

Total amount of type "E" grease: approximately 1 oz.

