

F-15 (FN65DA)

15 GAUGE FINISH NAILER

SENCO[®]



Parts Reference Guide



* Schematic drawings inside

Senco Brands, Inc.
4270 Ivy Pointe Blvd.
Cincinnati, OH 45245
www.senco.com
EMEA - www.verpa-senco.com

Questions? Comments? call SENCO's toll-free Action-line:
1-800-543-4596 (North & South America only)
or e-mail: toolprof@senco.com

FN65DA 15 Gauge Finish Nailer

SENCO[®]

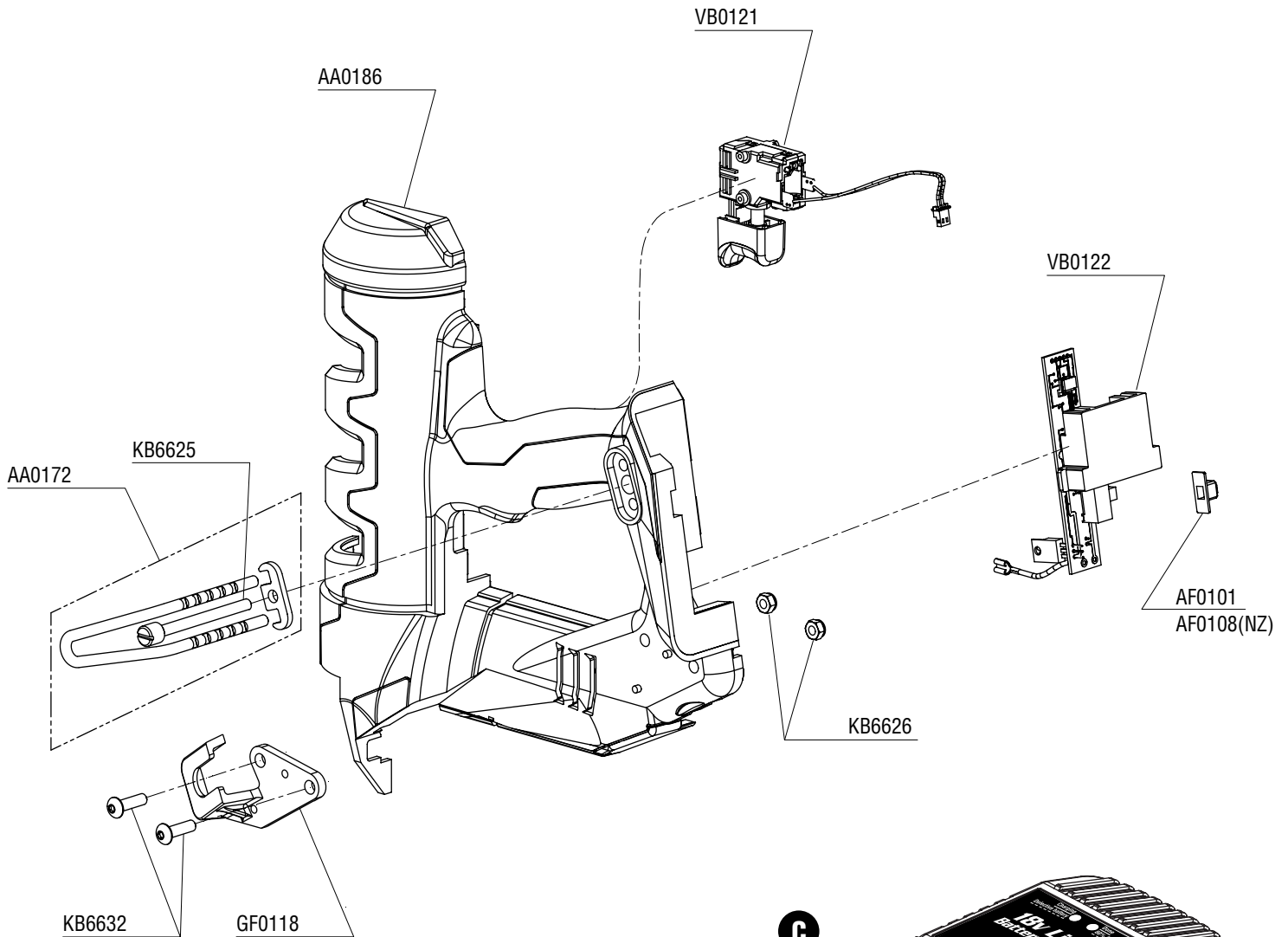

Tool #	A	B	C
5N0001N (US / S. AM.)	GA0684	VB0118	VB0120
5N2001N (EU)	GA0686	VB0129	VB0130
5N3001N (AU)	GA0684	VB0129	VB0131
5N3501N (NZ)	GA0684	VB0129	VB0131
5N7001N (UK)	GA0686	VB0129	VB0132

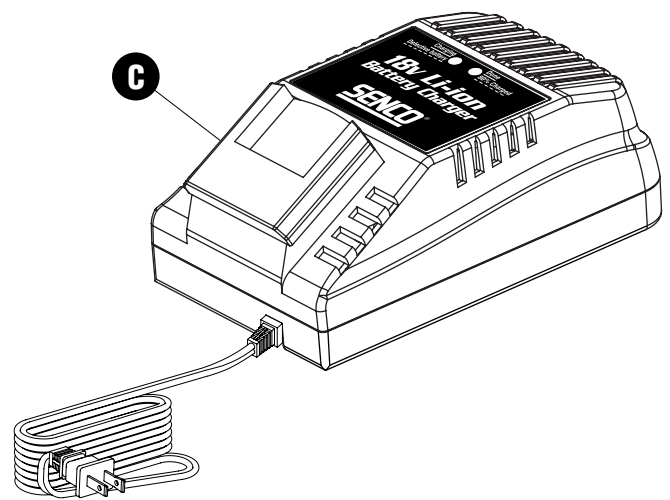

FN65DA 15 Gauge Finish Nailer

SENCO

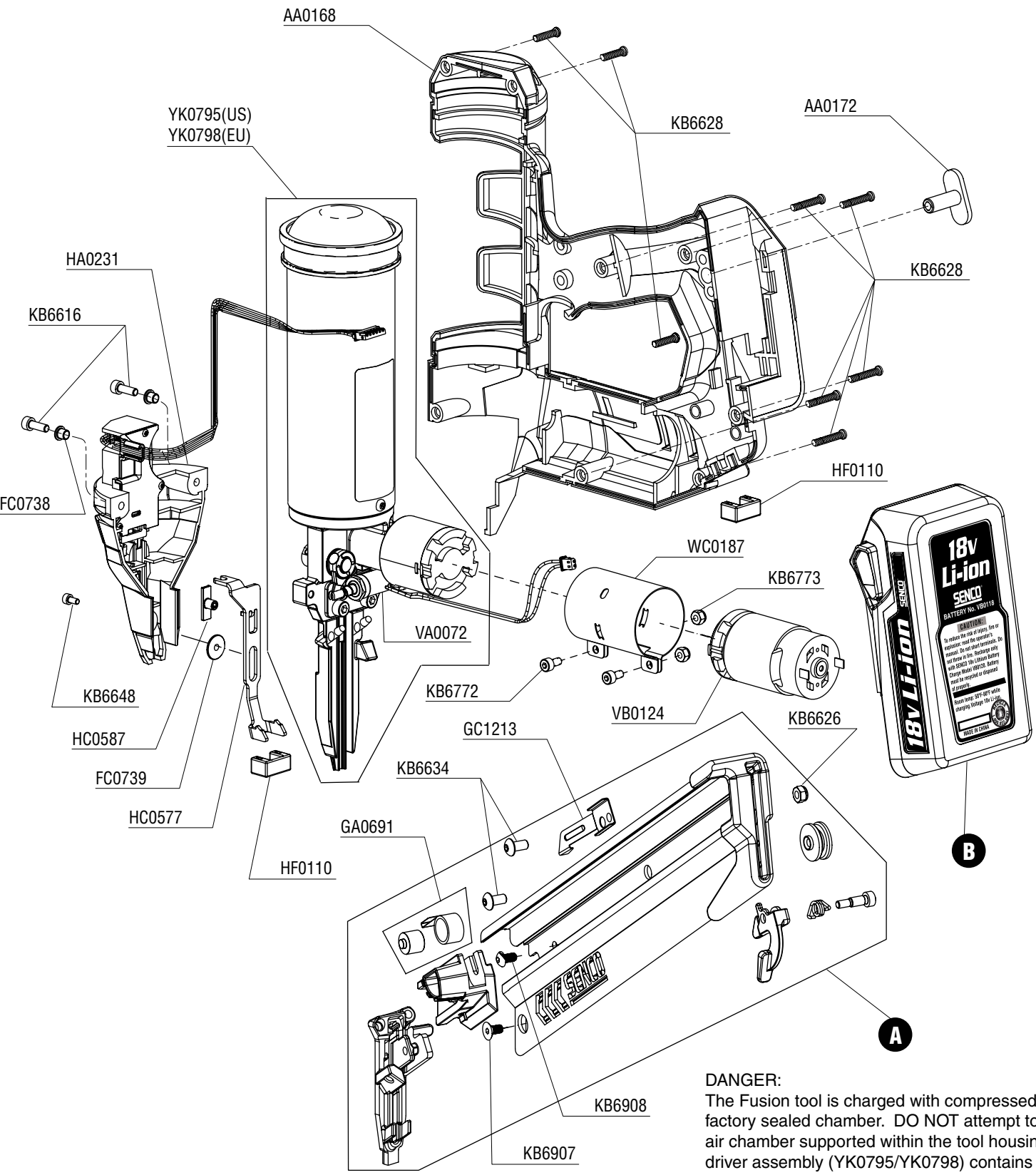

DANGER:
 The Fusion tool is charged with compressed air in a factory sealed chamber. **DO NOT** attempt to open the air chamber supported within the tool housing. The driver assembly (YK0795/YK0798) contains no user-serviceable parts. Major components such as the piston/driver assembly, gearbox, piston stop and guide body are all part of the drive assembly.

- Deliberate tampering with the drive assembly may result in the release of the driver.
- Any repair or upgrade requiring access to the pressure chamber should be handled by an authorized Senco dealer or service center.

FN65DA 15 Gauge Finish Nailer

REPLACEMENT PARTSLIST • LISTA DE PARTES DE REPUESTO • ERSATSTEILE-LISTE • LISTE DE PIÈCES DE RECHANGE

PART NO.	DESCRIPTION	DESCRIPCIÓN	BESCHREIBUNG	DÉSIGNATION
AA0172	BELT HOOK	GANCHO DE CINTURÓN	GURTHAKEN	CROCHET DE CEINTURE
AA0168	BODY, RIGHT HALF	CARCASA	GEHÄUSE	CORPS
AA0186	BODY, LEFT HALF	CARCASA	GEHÄUSE	CORPS
AF0101	COVER	CUBIERTA	ABDECKUNG	COUVERCLE
AF0108	COVER (NZ)	CUBIERTA	ABDECKUNG	COUVERCLE
FC0738	STANDOFF	SEPARADOR	SISTANZSTÜCK	ENTRETOISE
FC0739	STANDOFF	SEPARADOR	SISTANZSTÜCK	ENTRETOISE
GA0684	RAIL ASSY (U.S./S.A./AU/NZ)	CARRIL	SCHIENE	RAIL
GA0686	RAIL ASSY (EU/UK)	CARRIL	SCHIENE	RAIL
GA0691	FEED SPRING ASY	RESORTE	FEDER	RESSORT
GC1213	DETAINER	RETENEDOR	SPERRE	ARRÊT
GF0118	BRACKET, MOUNTING	SOPORTE	HALTERUNG	CAVALIER
HA0231	SAFETY ASSY	ASAMBLE DE SEGURO	SICHERHEITSVORRICHTUNG	PALPEUR DE SÉCURITÉ
HC0577	SAFETY ELEMENT	ASAMBLE DE SEGURO	SICHERHEITSVORRICHTUNG	PALPEUR DE SÉCURITÉ
HC0587	INDICATOR	MANOMÉTRICA	ZEIGER	BAGUETTE
HF0110	NO-MAR PAD	AMORTIGUADOR	SCHUTZ	COUSSIN
KB6616	SCREW	TORNILLO	SCHRAUBE	VIS
KB6625	SCREW	TORNILLO	SCHRAUBE	VIS
KB6626	NUT	TUERCA	MUTTER	ÉCROU
KB6628	SCREW	TORNILLO	SCHRAUBE	VIS
KB6632	SCREW	TORNILLO	SCHRAUBE	VIS
KB6634	SCREW	TORNILLO	SCHRAUBE	VIS
KB6648	SCREW	TORNILLO	SCHRAUBE	VIS
KB6772	SCREW	TORNILLO	SCHRAUBE	VIS
KB6773	NUT	TUERCA	MUTTER	ÉCROU
KB6907	SCREW	TORNILLO	SCHRAUBE	VIS
KB6908	SCREW	TORNILLO	SCHRAUBE	VIS
VA0072	SOLENOID	SOLENOIDE	MAGNETVENTIL	SOLÉNOIDE
VB0118	BATTERY (U.S./S.A.)	BATERIA	BATTERIE	BATTERIE
VB0120	CHARGER (U.S./S.A.)	CARAGADOR	LADEGERÄT	CHARGEUR
VB0121	TRIGGER	GATILLO	AUSLÖSER	GÂCHETTE
VB0122	PCB HOUSING	ALOJAMIENTO	GEHÄUSE	CORPS
VB0124	MOTOR, DRIVE ASY	MOTOR IMPULSOR	ANTRIEBSMOTOR	MOTEUR, ENTRA
VB0129	BATTERY (EU/AU/UK/NZ)	BATERIA	BATTERIE	BATTERIE
VB0130	CHARGER (EURO)	CARAGADOR	LADEGERÄT	CHARGEUR
VB0131	CHARGER (AU/NZ)	CARAGADOR	LADEGERÄT	CHARGEUR
VB0132	CHARGER (U.K.)	CARAGADOR	LADEGERÄT	CHARGEUR
WC0187	CLAMP	ALOJAMIENTO	GEHÄUSE	CORPS
YK0795	DRIVE ASY(US)	MECHANISM DE PERCUSOR	TREIBEN-ZUSAMMENBAU	ENFONCER D'ASSEMBLÉE
YK0798	DRIVE ASY(EU)	MECHANISM DE PERCUSOR	TREIBEN-ZUSAMMENBAU	ENFONCER D'ASSEMBLÉE