

5 EXPLODED VIEW

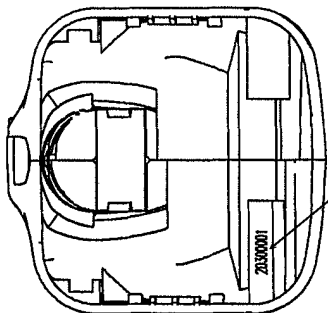
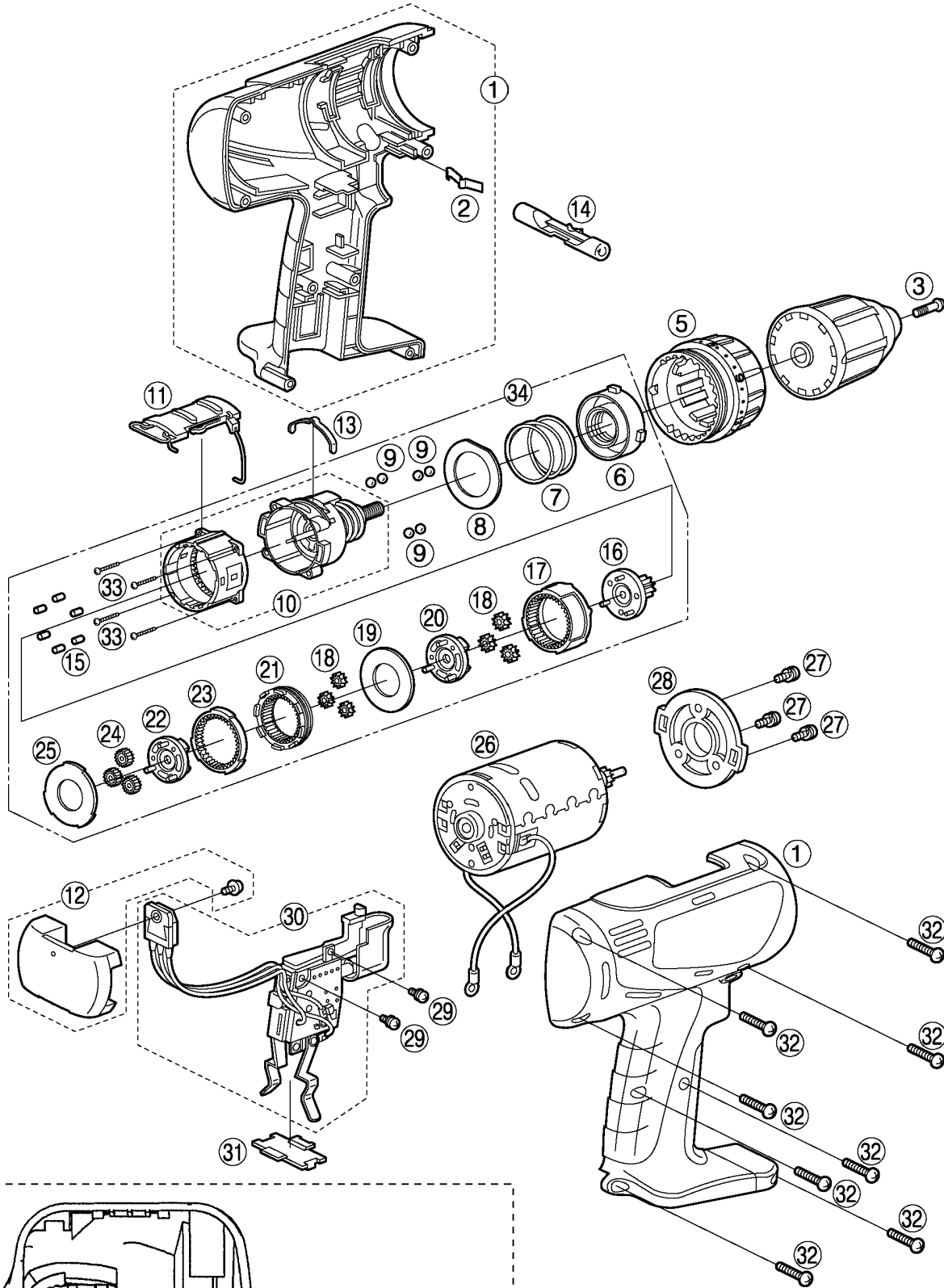

Production marking 8 digits.
 2 03 00001
 ↑ ↑ ↑
 Year Month Serial number

6.2. EY6409 REPLACEMENT PARTS LIST

NOTE:

*B=only available as set

*C=available individually

Ref.No.	Part No.	Part Name & Description	Remarks	Per Unit
1	WEY6409K3078	HOUSING AB SET	▲	1
2	EY6481L0177	CLICK SPRING		1
3	EYT103L6807	CHUCK FASTENING SCREW	▲	1
5	EY6406Y3228	CLUTCH HANDLE	▲	1
6	EY6406L0638	ADJUSTING SCREW	▲	1
7	EY6406L0168	CLUTCH SPRING	▲	1
8	EY6406L0578	CLUTCH PLATE	▲	1
9	EY560B6967	STEEL BALL	*B (12pcs/PK)	12
10	EY6406L1078	DRIVING BLOCK	▲	1
11	EY6406Y3238	H/L CHANGE HANDLE	▲	1
12	EY6406L2568	HEAT SINK	▲	1
13	EY6406L0178	CLICK SPRING A	▲	1
14	WEY6405Y3248	F/R SELECTOR HANDLE	▲	1
15	EY6283L0377	ROLLER PIN	*B (6pcs/PK)	6
16	EY6406L1118	CARRIER	▲	1
17	EY6406L1488	RING GEAR	▲	1
18	EY6406L1348	PLANET GEAR	*B (3pcs/PK)	6
19	EY6406L0858	THRUST PLATE	▲	1
20	EY6406L1128	CARRIER A	▲	1
21	EY6406L1468	RING GEAR A	▲	1
22	EY6406L1108	CARRIER B	▲	1
23	EY6406L1478	RING GEAR B	▲	1
24	EY6406L1358	PLANET GEAR B	*B (3pcs/PK)	3
25	EY6406L0888	THRUST PLATE	▲	1
26	WEY6405L1008	DC MOTOR	▲	1
27	EY6230L6027	SCREW	*C K3*6	3
28	EY6406L0028	MOTOR MOUNTING PLATE	▲	1
29	EY6207Y6027	SCREW	*C K3*5	2
30	WEY6405Y2008	SWITCH	▲	1
31	EY6230L0207	DUST PREVENTIVE PLATE	▲	1
32	EY6230K9218	TAPPING SCREW	*C K3*20	8
33	EY6406K9038	TORX TAPPING SCREW	*C K3*12	4
34	EY6406L1458	GEAR BOX BLOCK	▲	1
-	WEY6405K8108	OPERATING INSTRUCTIONS	▲	1

**Battery Pack, Keyless Chuck, Quick Change Chuck and Tool Case are available as an optional accessory. See the nearest sales dealer for details.

***For replacement parts of charger, see the charger service manual.

Charger complete set is available as an optional accessory. See the nearest sales dealer for details.