



# SERVICE PARTS LIST

**BULLETIN NO.**  
**55-40-1602**

SPECIFY CATALOG NO. AND SERIAL NO. WHEN ORDERING PARTS		REVISED BULLETIN	DATE
<b>CORDLESS SAWZALL®</b>		55-40-1601	Jan. 2007
CATALOG NO.	6515-50	STARTING SERIAL NO.	971C
		WIRING INSTRUCTION	
		<b>58-01-0790</b>	

**EXAMPLE:**

Component Parts (Small #)  
Are Included When Ordering  
The Assembly (Large #).

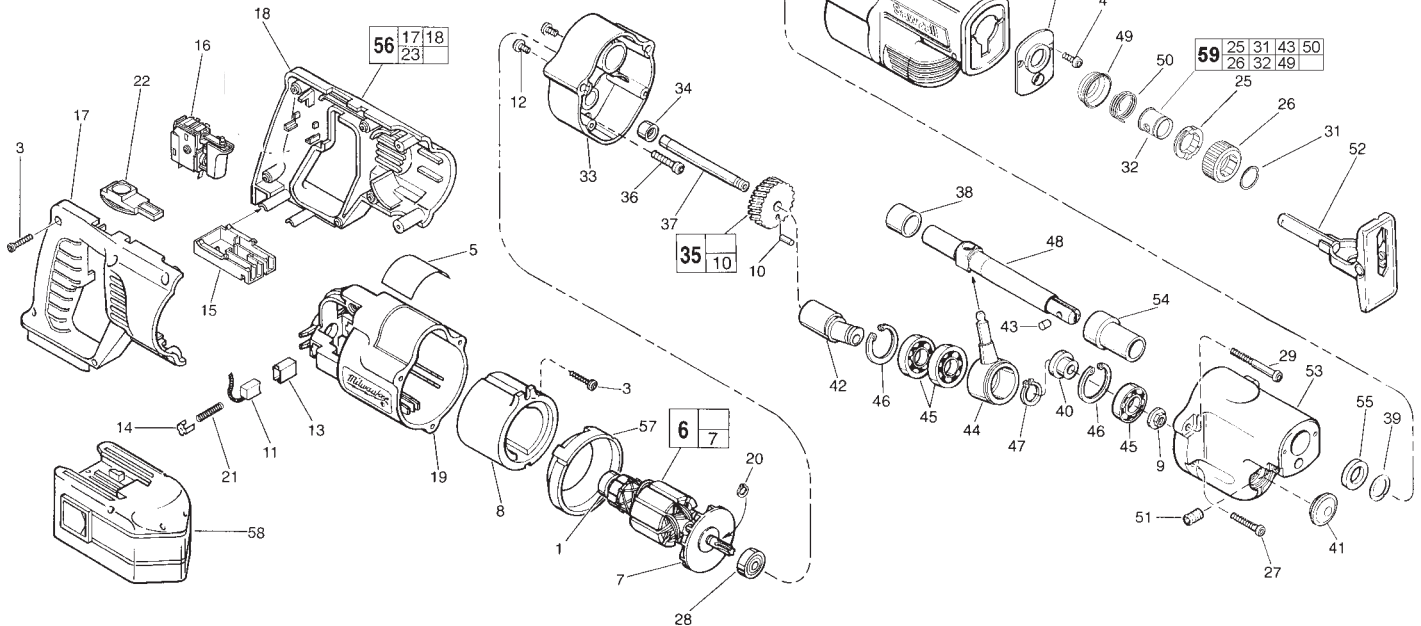

FIG.	PART NO.	DESCRIPTION OF PART	NO. REQ.
1	02-04-5130	Ball Bearing	(1)
3	06-82-7261	6-19 x 11/16" Pan Hd. Slit. Plastite T-15	(8)
4	06-95-0080	6-32 x 1/2" Truss Hd. Taptite T-10 Screw	(2)
★ 5	12-20-3420	Service Nameplate Kit	(1)
★ 6	16-01-1140	Armature	(1)
★ 7	22-84-0950	Fan Assembly	(1)
★ 8	18-01-0070	Field	(1)
9	06-55-3790	5/16-24 Spinlock Hex Nut	(1)
10	06-65-0606	3/16" x 1/2" Drivelok Pin	(1)
11	22-18-0975	Carbon Brush Assy.-Right	(1)
11A	22-18-0970	Carbon Brush Assy.-Left (Not Shown)	(1)
12	06-82-7252	8-32 x 3/8" Pan Hd. Taptite T-20	(2)
13	22-20-0860	Brush Tube	(2)
14	22-32-0400	Brush Spring Clip	(2)
15	22-56-0230	Connector Block	(1)
16	23-66-2351	Switch Assembly	(1)
17	31-44-0750	Handle Half-Right	(1)
18	31-44-0755	Handle Half-Left	(1)
19	31-50-0961	Motor Housing	(1)
★ 20	34-60-0810	External Retaining Ring	(1)
21	40-50-8840	Brush Spring	(2)
22	45-24-0201	Lock Off Slide	(1)
24	44-86-0615	Seal Retainer	(1)
25	42-50-0077	Cam Collar	(1)
26	42-50-0076	Front Cam	(1)
27	06-82-5346	8-32 x 3/4" Pan Hd. Taptite T-20	(2)
★ 28	02-04-1017	Ball Bearing	(1)
29	05-88-8301	K50 x 60mm Pan Hd. PT T-20	(2)
30	45-12-0510	Gear Case Insulator	(1)
31	34-60-3680	External Retaining Ring	(1)
32	45-22-0081	Sleeve	(2)
33	28-28-2080	Diaphragm	(1)
34	02-50-2150	Needle Bearing	(1)
★ 35	32-40-2365	Intermediate Gear Assembly	(1)
36	05-88-8307	K50 x 22mm Pan Hd. PT T-20	(1)
37	42-12-0180	Axle-Wobble Shaft	(1)
38	42-24-0620	Rear Spindle Bearing	(1)
39	45-88-8577	Washer	(1)
40	45-36-1450	Spacer	(1)
41	42-52-0380	Bearing Cap	(1)

FIG.	PART NO.	DESCRIPTION OF PART	NO. REQ.
42	36-92-0740	Wobble Shaft	(1)
43	44-60-0626	Pin	(1)
44	30-72-0111	Wobble Plate	(1)
45	02-04-1510	Ball Bearing	(3)
46	34-80-2600	Internal Retaining Ring	(2)
47	34-60-1315	External Retaining Ring	(1)
48	38-50-6005	Reciprocating Spindle	(1)
49	31-15-0511	Spring Cover	(1)
50	40-50-0161	Torsion Spring	(1)
51	06-83-3151	5/16-18 x 1/2" Hex Socket Hd. Set Screw	(1)
52	45-16-0615	Pivot Shoe Assembly	(1)
53	28-14-2180	Gear Case	(1)
54	42-24-0615	Forward Spindle Bearing	(1)
★ 55	45-06-0501	Felt Seal	(1)
56	31-44-0775	Handle Kit	(1)
57	31-05-0080	Baffle	(1)
58	-----	Battery (Accessory)	(1)
59	14-46-1011	Steel Quik-Lok Blade Clamp Kit	(1)
	49-96-0070	5/32" Hex Key	(1)
	23-94-5890	Leadwire Assy.-Black (See 58-01-0790)	(1)
	23-94-5895	Leadwire Assy.-White (See 58-01-0790)	(1)

**FIG. 11, 11A, 13 NOTES:**  
Remove Brushes And Brush Tubes To Prevent Damage  
When Installing Or Removing Armature From Motor Hsg.

**SEE REVERSE SIDE FOR  
IMPORTANT SERVICE NOTES**

**MILWAUKEE ELECTRIC TOOL CORPORATION**  
13135 W. LISBON RD., BROOKFIELD, WI 53005

**FIG. LUBRICATION**

- 33 Place 3/4 oz. of type "L" grease, No. 49-08-4175, in diaphragm cavity near needle bearing.
- 53 Place 2-3/4 oz. of type "L" grease, No. 49-08-4175, in mechanism cavity of gear case.
- 55 Saturate with lightweight oil before assembly.

**FIG. NOTES**

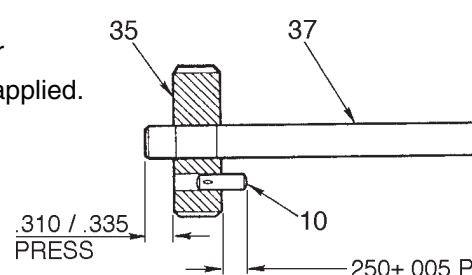
- 9 Apply thread locking compound to threads of spinlock hex nut. Torque to 145in./lbs.-185 in./lbs.
- 9,10,35,37 Axle should extend .285 min. beyond intermediate gear after seating torque to spinlock hex nut (not shown) is applied.  
Pin is to be pressed into gear as shown.
- 20 Seal side faces commutator.  

- 20,28,45 Press bearings to shaft shoulders.
- 33,38 Press rear spindle bearing flush to .030 below bearing boss of diaphragm.
- 34 Press bearing flush ( $\pm .005$ ) to diaphragm surface.
- 39 O-ring of seal towards rear of tool.
- 45,46 Retaining rings are to be installed with the beveled side away from the bearings.
- 53,54 Press forward spindle bearing flush to .030 below bearing boss of gear case.

**REMOVING THE STEEL QUIK-LOK® BLADE CLAMP**

- Remove external retaining ring (31) and pull front cam (26) off.
- Pull lock pin (43) out and remove remainder of parts and discard.

**REASSEMBLY OF THE STEEL QUIK-LOK® BLADE CLAMP**

- Coat new lock pin with powdered graphite.
- Hold tool in a vertical position.
- Place spring cover (49) onto spindle.
- Slide torsion spring (50) onto spindle with spring leg on hole side of spindle.
- Slide sleeve (32) onto spindle aligning hole on sleeve with hole in spindle.
- Slide rear cam (25) over sleeve until it bottoms on sleeve shoulder, ensure spring leg inserts into hole in rear cam.
- Rotate rear cam in the direction of the arrows located on spring cover until there is clearance for lock pin (43) to be inserted into sleeve/spindle holes. Insert lock pin.
- Align front cam (26) inner ribs with rear cam outer slots and slide front cam onto sleeve until it bottoms. Retaining ring (31) groove should be completely visible.
- Attach retaining ring by separating coils and inserting end of ring into groove, then wind remainder of ring into groove. Ensure ring is seated in groove.
- Blade clamp should rotate freely. During normal usage, debris may not allow blade clamp to rotate freely. The use of spray lubricant can help free blade clamp. In extreme conditions, follow these instructions to remove, clean and reassemble blade clamp.

