



SERVICE PARTS LIST

BULLETIN NO.
54-40-0731

SPECIFY CATALOG NO. AND SERIAL NO. WHEN ORDERING PARTS		REVISED BULLETIN 54-40-0730	DATE Feb.'99
SAWZALL PLUS®			
CATALOG NO.	6518	STARTING SERIAL NO.	859G
		WIRING INSTRUCTION 58-01-0781	

EXAMPLE:
00/0 Component Parts (Small #) Are Included
When Ordering The Assembly (Large #).

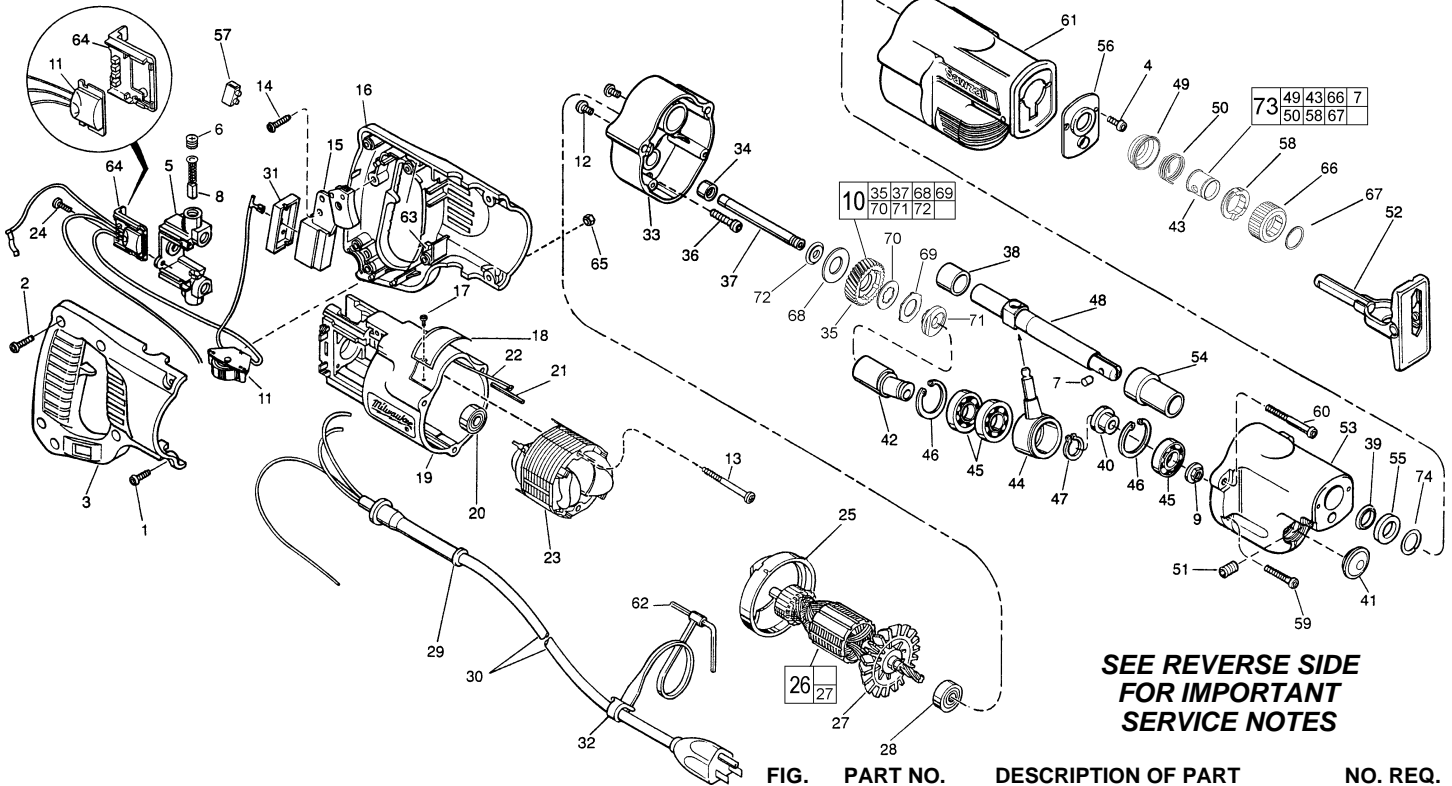

**SEE REVERSE SIDE
FOR IMPORTANT
SERVICE NOTES**

FIG.	PART NO.	DESCRIPTION OF PART	NO. REQ.
1	06-82-2390	8-32 x 1-1/4" Slotted Pan Hd. T-20	(2)
2	06-82-7270	8-16 x 5/8" Pan Hd. Plastite T-20	(5)
3	31-44-1651	Right Handle Half	(1)
★4	06-95-0080	6-32 x 1/2" Truss Hd. Taptite T-10	(2)
5	22-22-1380	Brush Holder Assembly	(1)
6	23-44-0190	Brush Retaining Cap	(2)
★7	44-60-0626	Lock Pin	(1)
8	22-18-0910	Carbon Brush Assembly	(2)
9	06-55-3790	5/16-24 Spinlock Hex Nut	(1)
10	32-40-2310	IPS Gear Assembly	(1)
11	14-20-3020	Dial Assembly	(1)
12	06-82-7252	8-32 x 3/8" Pan Hd. Taptite T-20	(2)
13	06-82-7410	8-16 x 1-7/8" Pan Hd. Slit. Plastite T-20	(2)
14	06-82-7270	8-16 x 5/8" Pan Hd. Plastite T-20	(1)
15	23-66-1490	Switch	(1)
16	31-44-1656	Left Handle Half	(1)
17	06-72-1720	Nameplate Rivet	(2)
18	12-99-1735	Service Nameplate	(1)
19	31-50-0020	Motor Housing	(1)
20	02-04-0845	Ball Bearing	(1)
21	44-60-0530	Ground Pin	(1)
22	23-94-6100	Ground Wire Assembly	(1)
23	18-31-0600	120 V. Field	(1)
24	06-82-7240	6-19 x 1/2" Pan Hd. Slot. Plastite T-15	(2)
25	31-05-0055	Baffle	(1)
26	16-30-0560	120 V. Armature	(1)
27	22-84-0531	Fan Assembly	(1)
28	02-04-0911	Ball Bearing	(1)
29	44-76-0210	Cord Protector	(1)
30	22-64-3190	Cord Set	(1)
31	45-12-0470	Dust Shield	(1)
32	48-66-4080	Key Holder	(1)
33	28-28-2080	Diaphragm	(1)
34	02-50-2150	Needle Bearing	(1)
35	32-40-2095	Gear	(1)
36	05-88-8307	K50 x 22mm Pan Hd. PT T-20	(1)
37	42-12-0180	Axle-Wobble Shaft	(1)

FIG.	PART NO.	DESCRIPTION OF PART	NO. REQ.
38	42-24-0620	Rear Spindle Bearing	(1)
39	45-06-0475	Poly-Pak Seal	(1)
40	45-36-1450	Spacer	(1)
41	42-52-0380	Bearing Cap	(1)
42	36-92-0750	Wobble Shaft	(1)
★43	45-22-0081	Sleeve	(1)
44	30-72-0111	Wobble Plate	(1)
45	02-04-1510	Ball Bearing	(3)
46	34-80-2600	Internal Retaining Ring	(2)
47	34-60-1315	External Retaining Ring	(1)
48	38-50-6005	Reciprocating Spindle	(1)
★49	31-15-0511	Spring Cover	(1)
★50	40-50-0161	Torsion Spring	(1)
51	06-83-3150	5/16-18 x 1/2" Hex Socket Hd. Set Screw	(1)
52	45-16-0615	Pivot Shoe Assembly	(1)
53	28-14-2180	Gear Case	(1)
54	42-24-0615	Forward Spindle Bearing	(1)
55	45-06-0500	Felt Seal	(1)
56	44-86-0615	Seal Retainer	(1)
57	22-56-0456	Terminal Block	(1)
★58	42-50-0077	Rear Cam	(1)
59	06-82-5346	8-32 x 3/4" Pan Hd. Taptite T-20	(2)
60	05-88-8301	K50 x 60mm Pan Hd. PT T-20	(2)
61	45-12-0510	Gear Case Insulator	(1)
62	49-96-0070	5/32" Hex Key	(1)
63	14-46-1001	Foam Slug Kit (10 Slugs)	(2)
64	43-72-0176	Heat Sink Holder	(1)
65	06-55-0835	8-32 Hex Nut	(2)
★66	42-50-0076	Front Cam	(1)
★67	34-60-3680	External Retaining Ring	(1)
68	40-50-8850	Disc Spring	(1)
69	43-06-0675	Bronze Disc	(1)
70	43-06-0685	Metal Disc	(1)
71	43-78-0525	Drive Hub	(1)
72	43-78-0530	Spring Retainer	(1)
★73	14-46-1011	Steel Quik-Lok Blade Clamp Kit	(1)
★74	45-88-8577	Washer	(1)

MILWAUKEE ELECTRIC TOOL CORPORATION
13135 W. LISBON RD., BROOKFIELD, WI 53005