



SERVICE PARTS LIST

BULLETIN NO.
55-40-7026

SPECIFY CATALOG NO. AND SERIAL NO. WHEN ORDERING PARTS		REVISED BULLETIN 55-40-7025	DATE Dec. 2002
SUPER SAWZALL®		WIRING INSTRUCTION 58-03-1701	
CATALOG NO. 6528-55	STARTING SERIAL NUMBER 948C or 948D		

EXAMPLE:

Component Parts (Small #)
Are Included When Ordering
The Assembly (Large #).

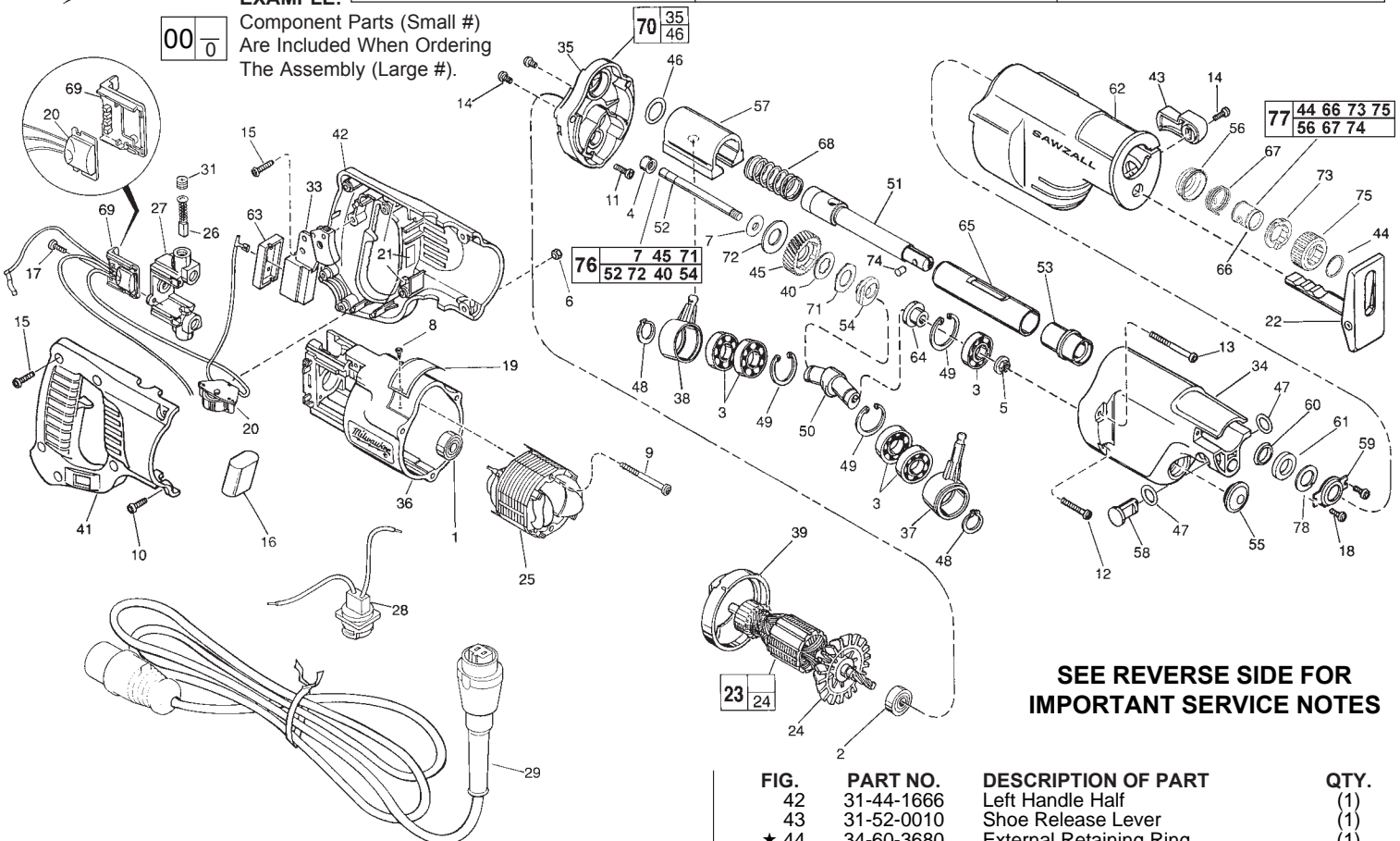

**SEE REVERSE SIDE FOR
IMPORTANT SERVICE NOTES**

FIG.	PART NO.	DESCRIPTION OF PART	QTY.
1	02-04-0845	Ball Bearing	(1)
2	02-04-0911	Ball Bearing	(1)
3	02-04-1510	Ball Bearing	(5)
4	02-50-2150	Needle Bearing	(1)
5	06-55-3790	Spinlock Hex Nut 5/16-24	(1)
6	06-55-0835	8-32 Hex Nut	(2)
★ 7	45-88-1555	Washer	(1)
8	06-72-1720	Nameplate Rivet	(2)
9	06-82-7410	8-16 x 1-7/8" Pan Hd. Slit. Plastite T-20	(2)
10	06-82-2390	8-32 x 1-1/4" Pan Hd. Slit. T-20	(2)
11	05-88-8307	Pan Hd. PT T-20	(1)
12	06-82-5390	8-32 x 1-1/4" Pan Hd. Slit. Tapt. T-20	(2)
13	05-88-8301	Pan Hd. PT T-20	(2)
14	06-82-7252	8-32 x 3/8" Pan Hd. Slit. Tapt. T-20	(3)
15	06-82-7270	8-16 x 5/8" Pan Hd. Slit. Plas. T-20	(6)
16	14-20-0580	Suppressor Assembly	(1)
17	06-82-7240	6-19 x 1/2" Pan Hd. Plastite T-15	(2)
18	06-95-0075	6-32 x 3/8" Truss Hd. Taptite T-10	(2)
19	12-99-2090	Service Nameplate	(1)
20	14-20-3051	Remote Dial Assembly	(1)
21	14-46-1001	Foam Slug Kit - 10 Slugs	(3)
22	14-74-0270	Shoe Assembly	(1)
23	16-30-1460	Armature	(1)
24	22-84-0531	Fan Assembly	(1)
25	18-31-0500	Field	(1)
26	22-18-0910	Carbon Brush Assembly	(2)
27	22-22-1380	Brush Holder Assembly	(1)
28	22-56-0697	Pin Housing Assembly	(1)
★ 29	22-64-0676	Quik-Lok Cord Set	(1)
31	23-44-0190	Brush Retaining Cap	(2)
33	23-66-1975	Switch	(1)
34	28-14-2176	Gear Case	(1)
35	28-28-1876	Diaphragm	(1)
36	31-50-0020	Motor Housing	(1)
★ 37	30-72-0085	Primary Wobble Plate	(1)
★ 38	30-72-0093	Secondary Wobble Plate	(1)
39	31-05-0055	Baffle	(1)
40	43-06-0685	Metal Disc	(1)
41	31-44-1661	Right Handle Half	(1)

FIG.	PART NO.	DESCRIPTION OF PART	QTY.
42	31-44-1666	Left Handle Half	(1)
43	31-52-0010	Shoe Release Lever	(1)
★ 44	34-60-3680	External Retaining Ring	(1)
45	32-40-2095	Gear	(1)
46	34-40-1280	O-Ring	(1)
47	34-40-4200	O-Ring	(2)
48	34-60-1315	Ext. Retaining Ring	(2)
49	34-80-2600	Internal Retaining Ring	(3)
50	36-92-0701	Wobble Shaft	(1)
51	38-50-5835	Reciprocating Spindle	(1)
52	42-12-0150	Axle - Wobble Shaft	(1)
53	42-24-0430	Spindle Bearing	(1)
54	43-78-0525	Drive Hub	(1)
55	42-52-0380	Bearing Cap	(1)
★ 56	31-15-0511	Spring Cover	(1)
57	42-87-0090	Counter Balance	(1)
58	44-60-1200	Lock Pin	(1)
59	44-86-0375	Seal Retainer	(1)
60	45-06-0475	Polypak Seal	(1)
★ 61	45-06-0501	Felt Seal	(1)
★ 62	45-12-0462	Gear Case Insulator	(1)
63	45-12-0470	Dust Shield	(1)
64	45-36-1450	Spacer	(1)
65	45-76-0320	Tube Chassis	(1)
★ 66	45-22-0081	Sleeve	(1)
★ 67	40-50-0161	Torsion Spring	(1)
68	40-50-0165	Compression Spring	(1)
69	43-72-0176	Heat Sink Holder	(1)
70	28-28-2000	Diaphragm Assembly	(1)
71	43-06-0675	Bronze Disc	(1)
72	40-50-8850	Disc Spring	(1)
73	42-50-0077	Rear Cam	(1)
★ 74	44-60-0626	Lock Pin	(1)
★ 75	42-50-0076	Front Cam	(1)
76	32-40-2101	IPS Gear Assembly	(1)
★ 77	14-46-1011	Steel Quik-Lok Blade Clamp Kit	(1)
★ 78	45-88-8577	Washer	(1)
	22-56-0400	Lead Splice Connector (Not Shown)	(1)

- FIG. NOTES:**
- 1 Seal side faces commutator.
 - 2 Seal side faces fan.
 - 4 Press flush to diaphragm surface - Mechanism side.
 - 40, 45 Apply a thin coat of type "L" grease (Cat. No. 49-08-4175) between gear and metal disc.
 - 40 Tabs engage drive hub.
 - 71 Tabs engage gear.
 - 72 Concave towards gear.
 - 45, 52 See sketch for press specifications.

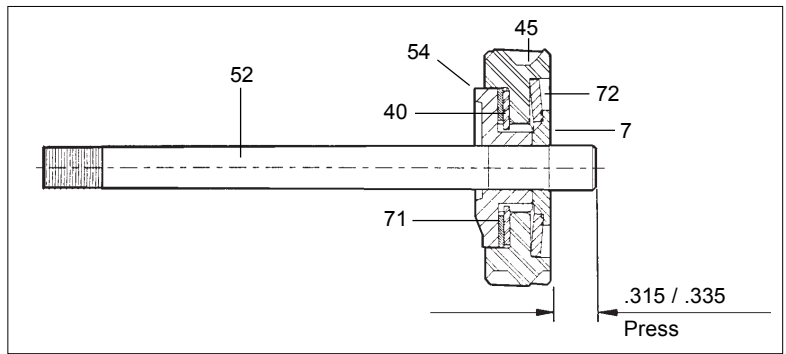

- 5 Apply thread locking compound to threads of spinlock hex nut. Torque to 145 in./lbs. to 185 in./lbs.
- 5, 45 Hold the gear still with a large pair of pliers and a piece of rubber hose (or other tough, but pliable material to protect the gear from the jaws of the pliers) and remove the 5/16" spinlock hex nut with a wrench, as shown.
- 50, 54 Make sure that the end of the wobble shaft fits into the offset (eccentric) recess, as shown.

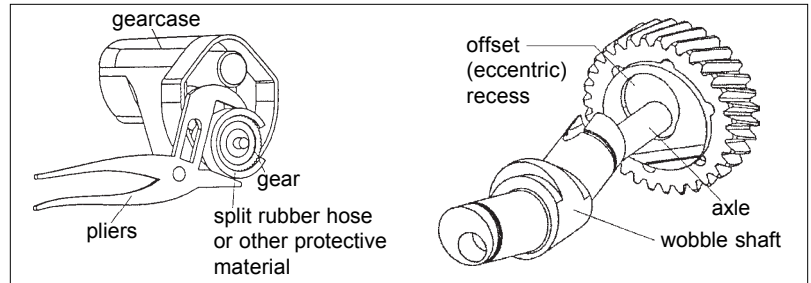

- 34 Place 2-3/4 oz. of type "L" grease (Cat. No. 49-08-4175), in mechanism cavity of gear case.
- 35 Place 3/4 oz. of type "T" grease (Cat. No. 49-08-4290), in lower needle bearing-gear train cavity of diaphragm.
- 37,38,49 Internal retaining ring side faces center hub of wobble shaft.
- 46 Replace each time gear case mechanism is serviced. O-ring opening of diaphragm and rear of tube chassis must be free of all grease prior to o-ring installation.
- 49 Sharp side of retaining ring faces ball bearing.
- 60 O-ring of polypak seal faces mechanism - toward rear of tool.
- 61 Soak in lightweight lubricating oil prior to assembly.
- 63 Non-conductive insulation of wires must pass through rubber dust shield; Provides proper sealing of switch from contamination.
- 65 Assembled with large O.D. chamfered end facing diaphragm- can be slip or press fit on spindle bearing.

REMOVING THE STEEL QUIK-LOK® BLADE CLAMP

- Remove external retaining ring (44) and pull front cam (75) off.
- Pull lock pin (74) out and remove remainder of parts and discard.

REASSEMBLY OF THE STEEL QUIK-LOK® BLADE CLAMP

- Coat new lock pin with powdered graphite.
- Hold tool in a vertical position.
- Place spring cover (56) onto spindle.
- Slide torsion spring (67) onto spindle with spring leg on hole side of spindle.
- Slide sleeve (66) onto spindle aligning hole on sleeve with hole in spindle.
- Slide rear cam (73) over sleeve until it bottoms on sleeve shoulder, ensure spring leg inserts into hole in rear cam.
- Rotate rear cam in the direction of the arrows located on spring cover until there is clearance for lock pin (74) to be inserted into sleeve/spindle holes. Insert lock pin.
- Align front cam (75) inner ribs with rear cam outer slots and slide front cam onto sleeve until it bottoms. Retaining ring (44) groove should be completely visible.
- Attach retaining ring by separating coils and inserting end of ring into groove, then wind remainder of ring into groove. Ensure ring is seated in groove.
- Blade clamp should rotate freely. During normal usage, debris may not allow blade clamp to rotate freely. The use of spray lubricant can help free blade clamp. In extreme conditions, follow these instructions to remove, clean and reassemble blade clamp.

