

Type:  
Part no.:

KBM 32 Q (60Hz,120V)  
72702709368



Item	Part no.	Designation	Quantity	Price RPR excl. VAT (USD)	AT
0010	31901107022	Motor housing	1	on req.	-
0020	51271003369	Stator	1	on req.	-
0030	43070004001	Screw	2	on req.	-
0040	31428112006	Air guide ring	1	on req.	-
0050	53271007360	Armature	1	on req.	-
0052	41701001172	Grooved ball bearing	1	on req.	-
0053	32416100000	Plate	1	on req.	-
0054	41701007050	Grooved ball bearing	1	on req.	-
0055	32612062001	Sealing ring	1	on req.	-
0100	31506370018	Intermediate bearing	1	on req.	-
0102	40608066005	Sealing ring	1	on req.	-
0103	41705038005	Needle sleeve	1	on req.	-
0104	41701001010	Grooved ball bearing	1	on req.	-
0140	43070007002	Screw	6	on req.	-
0145	40611007008	Sealing ring	4	on req.	-
0150	30712095020	Brush holder 110-120V 50/60Hz	2	on req.	-
0160	30711131000	Carbon brush	2	on req.	-
0170	31428138005	Holder	1	on req.	-
0180	30717189002	Connector	2	on req.	-
0190	31201114002	Cover	1	on req.	-
0200	30723046019	Screw connection	1	on req.	-
0205	40612024009	Sealing ring	1	on req.	-
0210	31414060012	Protective hose	1	on req.	-
0220	30719593011	Connecting cable	2	on req.	-
0240	31509083002	Gearbox housing	1	on req.	-
0245	31509083011	Gearbox housing	1	on req.	-
0250	41701204010	Grooved ball bearing	1	on req.	-
0260	41701017059	Grooved ball bearing	1	on req.	-
0270	42616004000	Circlip	1	on req.	-
0280	33403105002	Shaft	1	on req.	-
0290	40238065002	Clamping sleeve	1	on req.	-
0300	30901353006	Spiral spring	1	on req.	-
0305	30901353015	Spiral spring	1	on req.	-
0310	30503145006	Sleeve	1	on req.	-
0320	32408389000	Disc	1	on req.	-
0330	42616075007	Circlip	1	on req.	-
0340	41708025004	Ball	4	on req.	-
0350	30907063003	Spiral spring	1	on req.	-
0360	30232045005	Clamping sleeve	1	on req.	-
0380	42643009005	Circlip	1	on req.	-
0390	42616014009	Circlip	1	on req.	-
0400	40221028001	Feather key	1	on req.	-
0410	33663166008	Gear-wheel	1	on req.	-
0420	42616009003	Circlip	1	on req.	-
0430	33763060007	Shaft, toothed	1	on req.	-
0440	33657159006	Gear-wheel	1	on req.	-
0450	42443003043	Circlip M4	4	on req.	-
0460	43035009044	Cylinder head screw M4X20	2	on req.	-
0470	43035096049	Cylinder head screw	2	on req.	-

Type:  
Part no.:

KBM 32 Q (60Hz,120V)  
72702709368



Item	Part no.	Designation	Quantity	Price RPR excl. VAT (USD)	AT
0480	30240240007	Pressure piece	1	on req.	-
0490	32170017007	Lever	1	on req.	-
0500	41138025006	Hose socket	1	on req.	-
0602	31602081001	Bush	1	on req.	-
0603	31602092003	Bush	1	on req.	-
0605	31207277020	Housing	1	on req.	-
0610	33216047000	Pressure piece	1	on req.	-
0620	33218117000	Guide strip	2	on req.	-
0630	43035076041	Cylinder head screw M4X16	6	on req.	-
0640	30904041001	Leaf spring	1	on req.	-
0650	43041026994	Fillister head screw	1	on req.	-
0660	43058008051	Set screw	3	on req.	-
0670	42443004057	Circlip M5	6	on req.	-
0680	33812007004	Gear rack	1	on req.	-
0690	43035017057	Cylinder head screw M5X20	2	on req.	-
0700	33218116006	Guide	1	on req.	-
0710	43013048041	Flat headed screw	2	on req.	-
0740	33713068008	Shaft	1	on req.	-
0750	33213008009	Scale	1	on req.	-
0760	32119114014	Handle	3	on req.	-
0770	42401019085	Disc	2	on req.	-
0780	30905055000	Cup spring	2	on req.	-
0790	42019006080	Nut	1	on req.	-
0800	33216046021	Magnetic foot	1	on req.	-
0810	43035021050	Cylinder head screw M5X45	4	on req.	-
0825	30707333018	Cable with plug	1	on req.	-
0830	31413007007	Cable grommet	1	on req.	-
0840	30723044003	Screw connection	1	on req.	-
0845	30610034008	Seal	1	on req.	-
0850	32422317010	Plate	1	on req.	-
0860	31408086007	Plate	1	on req.	-
0870	30723043005	Nut	1	on req.	-
0875	30719647010	Connecting cable	2	on req.	-
0880	30701281000	Switch	1	on req.	-
0885	31412063000	Terminal	2	on req.	-
0888	30701281010	Switch Umbausatz / repair kit	1	on req.	-
0890	30762245990	Electronics	1	on req.	-
0900	30719572019	Connecting cable	4	on req.	-
0910	30701242009	Switch	1	on req.	-
0911	32816059009	Cap	1	on req.	-
0920	42439013046	Lock washer	1	on req.	-
0930	42404005048	Disc	2	on req.	-
0940	40612024009	Sealing ring	1	on req.	-
0950	32429135010	Cover	1	on req.	-
0960	30723046019	Screw connection	1	on req.	-
0970	30723045007	Nut	1	on req.	-
0975	30234026008	Cable tie	2	on req.	-
0980	43064023045	Fillister head screw	8	on req.	-
1000	32217406002	Information sign	1	on req.	-
5000	33901126020	Tool box ass.	1	on req.	-

Type:  
Part no.:

KBM 32 Q (60Hz,120V)  
72702709368



Item	Part no.	Designation	Quantity	Price RPR excl. VAT (USD)	AT
5010	30240247002	Bottle holder	1	on req.	-
5020	32132022007	Pump	1	on req.	-
5030	31414054008	Replacement hose	1	on req.	-
5040	64201001000	Hook f. chip removal	1	on req.	-
5050	32174008007	Lashing strap	1	on req.	-
5060	63203050014	Key-type drill chucks	1	on req.	-
5065	62914002005	Chuck key	1	on req.	-
5070	63901020006	QuickIN-adaptor	1	on req.	-
5080	30217332009	Centering pins	1	on req.	-
5095	30217355000	Centering pins	1	on req.	-
5100	43041008045	Fillister head screw	4	on req.	-
5110	63901037010	Contact and swarf protection	1	on req.	-
5130	63901021014	QuickIN-adaptor	1	on req.	-
5140	63901024019	QuickIN-adaptor	1	on req.	-
5150	30217337002	Centering pins	1	on req.	-
5160	30217338000	Centering pins	1	on req.	-
5210	30232050000	Wire clamp	2	on req.	-
6000	32160003182	Lubricant tube 0,085 kg	1	on req.	-
9000	34101011210	Operating instructions	1	on req.	-
9010	34151011000	List of spare parts KBM 32Q	1	on req.	-

Type:  
Part no.:

KBM 32 Q (60Hz,120V)  
72702709368

7 270 27 - KBM 32 Q

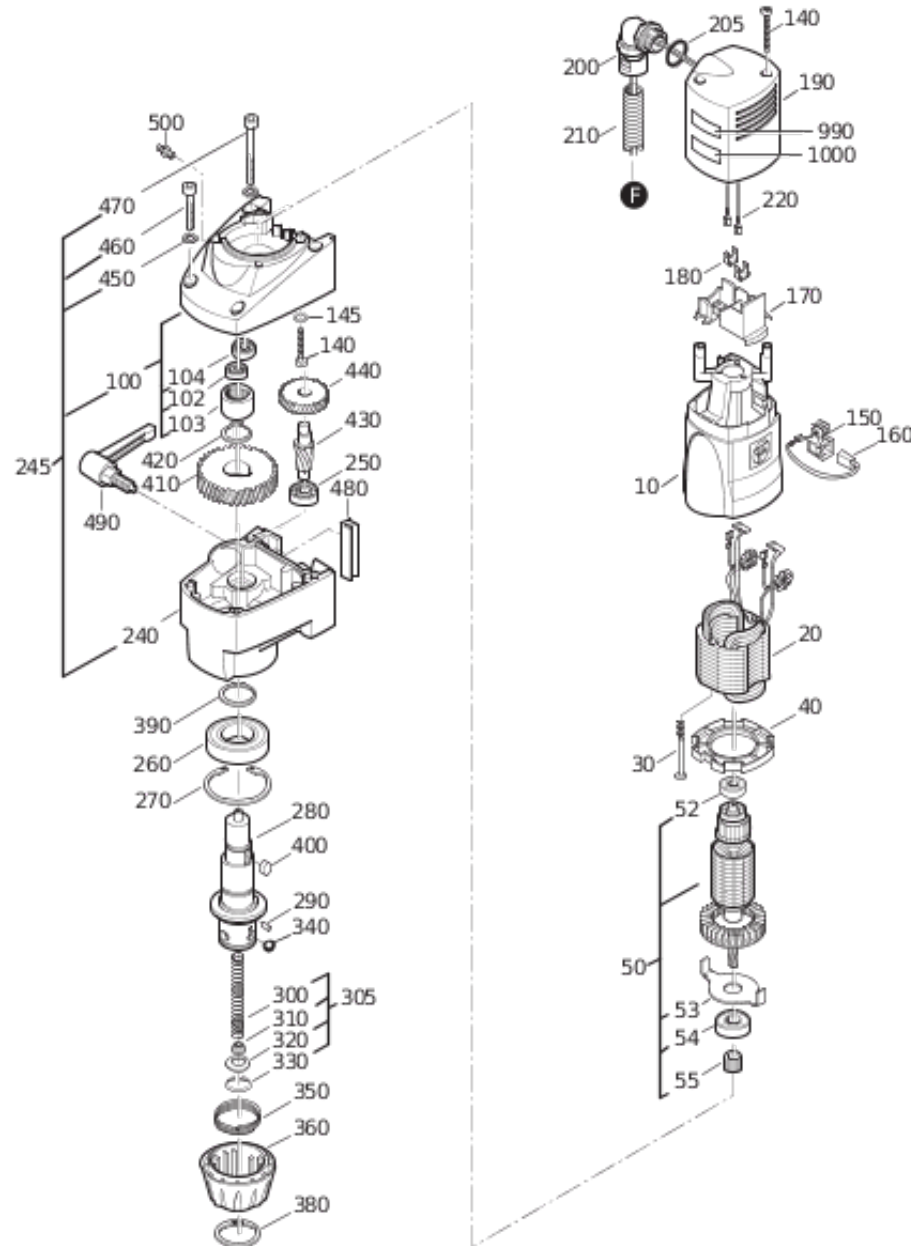

Type:  
Part no.:

KBM 32 Q (60Hz,120V)  
72702709368

7 270 27 - KBM 32 Q

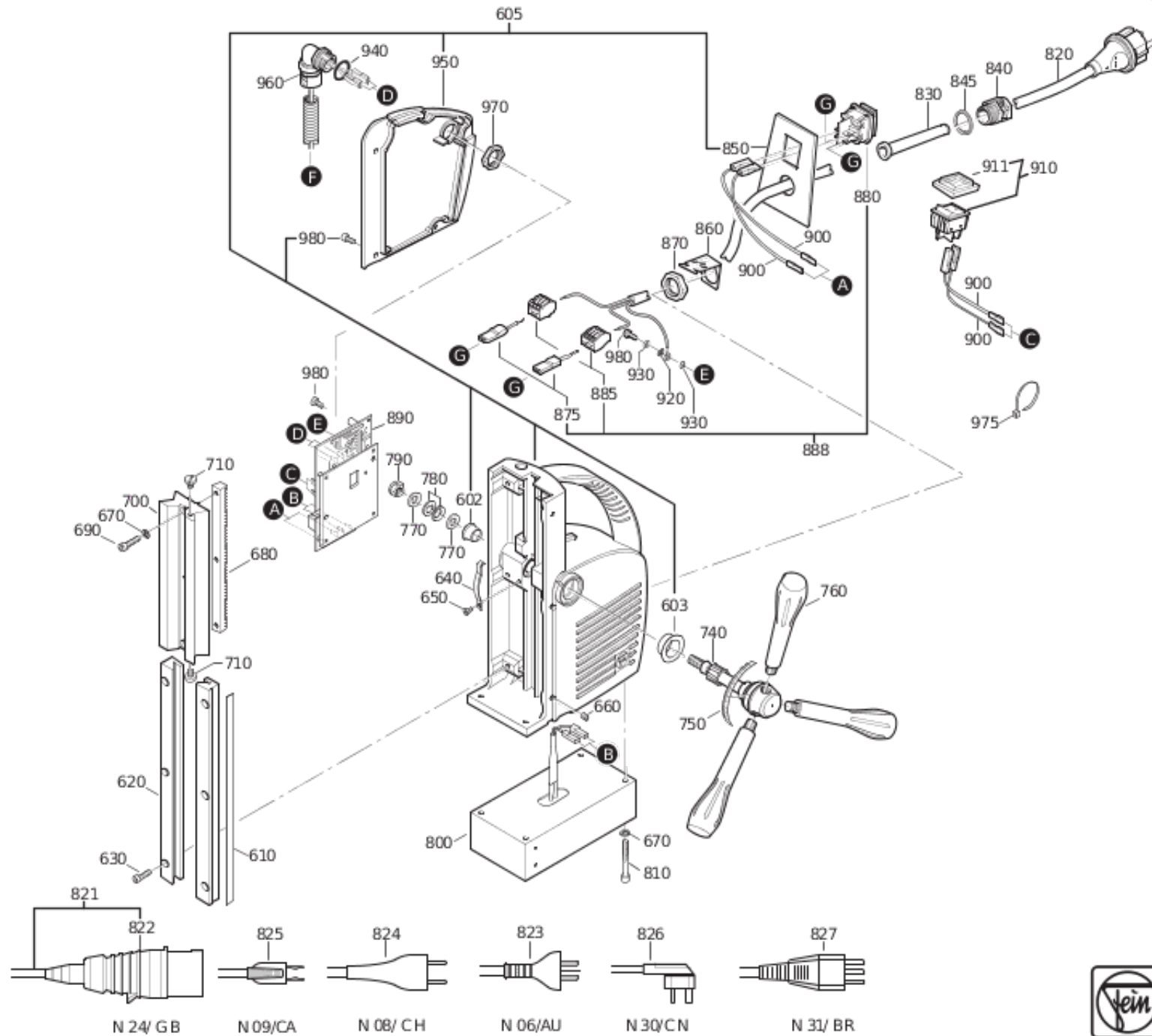

Type:  
Part no.:

KBM 32 Q (60Hz,120V)  
72702709368

7 270 27 - KBM 32 Q

