

**Bauart:**  
**Best.-Nr.:**

**JCM 200 Q (60Hz,120V)**  
**72703612360**



Pos.	Best.-Nr.	Benennung	Stk	Preis UVP o. MwSt. (USD)	AT
0010	31901165010	Motor housing	1	a. A.	-
0025	51273004110	Stator	1	a. A.	-
0030	31428118007	Air guide ring	1	a. A.	-
0040	53273007113	Armature 50/60Hz110-120V Z=6	1	a. A.	-
0050	41701001172	Grooved ball bearing	1	a. A.	-
0060	32416098005	Plate	1	a. A.	-
0070	41701007050	Grooved ball bearing	1	a. A.	-
0080	32612124006	Sealing ring	1	a. A.	-
0090	31506365008	Intermediate bearing	1	a. A.	-
0100	41701204010	Grooved ball bearing	3	a. A.	-
0110	40608066005	Sealing ring	1	a. A.	-
0120	41701012056	Grooved ball bearing	1	a. A.	-
0130	32805187009	Cap	1	a. A.	-
0135	42639028003	Sealing ring	1	a. A.	-
0140	43070005005	Screw	4	a. A.	-
0145	40611007008	Sealing ring	4	a. A.	-
0150	31406053007	Sleeve	1	a. A.	-
0160	32172010005	Ring magnet	1	a. A.	-
0170	30762259017	Electronics	1	a. A.	-
0190	30712088029	Brush holder	2	a. A.	-
0191	30711136002	Carbon brush	2	a. A.	-
0200	43070018009	Screw	2	a. A.	-
0210	31201121006	Cover	1	a. A.	-
0220	30723054002	Screw connection	2	a. A.	-
0230	40612115003	Sealing ring	3	a. A.	-
0240	31414061002	Protective hose	2	a. A.	-
0250	30719609014	Connecting cable	1	a. A.	-
0260	30719649010	Connecting cable	1	a. A.	-
0265	30719635010	Connecting cable	1	a. A.	-
0270	43070012008	Screw	2	a. A.	-
0280	31508248007	Gearbox housing	1	a. A.	-
0290	41701010010	Grooved ball bearing	1	a. A.	-
0300	41701017059	Grooved ball bearing	1	a. A.	-
0310	42616004000	Circlip	1	a. A.	-
0320	33403108007	Shaft	1	a. A.	-
0330	30901341000	Spiral spring	1	a. A.	-
0335	30901341019	Spiral spring	1	a. A.	-
0340	30503145006	Sleeve	1	a. A.	-
0350	32408389000	Disc	1	a. A.	-
0360	42616075007	Circlip	1	a. A.	-
0370	40238065002	Clamping sleeve	1	a. A.	-
0380	30907063003	Spiral spring	1	a. A.	-
0390	41708025004	Ball	4	a. A.	-
0400	30232045005	Clamping sleeve	1	a. A.	-
0410	42643009005	Circlip	1	a. A.	-
0420	42616014009	Circlip	1	a. A.	-
0430	40221040006	Feather key	1	a. A.	-
0440	33665055005	Gear-wheel Z=51	1	a. A.	-
0450	42616009003	Circlip	1	a. A.	-

**Bauart:**  
**Best.-Nr.:**

**JCM 200 Q (60Hz,120V)**  
**72703612360**



Pos.	Best.-Nr.	Benennung	Stk	Preis UVP o. MwSt. (USD)	AT
0460	33765019007	Shaft, toothed Z=13	1	a. A.	-
0470	40221067009	Feather key	1	a. A.	-
0480	33613128002	Gear-wheel Z=35	1	a. A.	-
0490	33613127004	Gear-wheel Z=43	1	a. A.	-
0500	42616007001	Circlip	1	a. A.	-
0510	33811068002	Shaft, toothed Z=21/13	1	a. A.	-
0520	33657169005	Gear-wheel Z=49	1	a. A.	-
0530	32805189001	Switch pushbutton	1	a. A.	-
0540	40242062002	Straight pin	1	a. A.	-
0560	30905059009	Cup spring	1	a. A.	-
0570	42616016006	Circlip	1	a. A.	-
0580	42443004057	Circlip M5	4	a. A.	-
0590	43035073052	Cylinder head screw M5X16	4	a. A.	-
0600	41138025006	Hose socket	1	a. A.	-
0610	30240240007	Pressure piece	1	a. A.	-
0620	32170017007	Lever	1	a. A.	-
0630	30719646010	Connecting cable	1	a. A.	-
0700	31207287010	Housing	1	a. A.	-
0702	31602081001	Bush	1	a. A.	-
0703	31602092003	Bush	1	a. A.	-
0710	33216047000	Pressure piece	1	a. A.	-
0720	33218117000	Guide strip	2	a. A.	-
0730	43035076041	Cylinder head screw M4X16	6	a. A.	-
0740	30904041001	Leaf spring	1	a. A.	-
0750	43041026994	Fillister head screw	1	a. A.	-
0760	43058008051	Set screw	3	a. A.	-
0770	42443004057	Circlip M5	7	a. A.	-
0780	33812007004	Gear rack	1	a. A.	-
0790	43035017057	Cylinder head screw M5X20	2	a. A.	-
0800	33218118008	Guide	1	a. A.	-
0810	43013048041	Flat headed screw	2	a. A.	-
0820	33713068008	Shaft	1	a. A.	-
0830	33213008009	Scale	1	a. A.	-
0840	32119114014	Handle	3	a. A.	-
0850	42401019085	Disc	2	a. A.	-
0860	30905055000	Cup spring	2	a. A.	-
0870	42019006080	Nut	1	a. A.	-
0880	33216049002	Magnetic foot	1	a. A.	-
0890	43035097059	Cylinder head screw	4	a. A.	-
0900	30707333018	Cable with plug	1	a. A.	-
0910	31413007007	Cable grommet	1	a. A.	-
0920	30723044003	Screw connection	1	a. A.	-
0930	30610034008	Seal	1	a. A.	-
0940	32422317000	Plate	1	a. A.	-
0950	31408086007	Plate	1	a. A.	-
0960	30723043005	Nut	1	a. A.	-
0970	30701281000	Switch	1	a. A.	-
0972	30719647010	Connecting cable	2	a. A.	-
0973	31412063000	Terminal	2	a. A.	-
0975	30701281010	Switch Umbausatz / repair kit	1	a. A.	-

**Bauart:**  
**Best.-Nr.:**

**JCM 200 Q (60Hz,120V)**  
**72703612360**



Pos.	Best.-Nr.	Benennung	Stk	Preis UVP o. MwSt. (USD)	AT
0990	30762274980	Electronics	1	a. A.	-
1000	30719614010	Connecting cable	2	a. A.	-
1010	30701280010	Switch	1	a. A.	-
1020	42404005048	Disc	2	a. A.	-
1030	42439013046	Lock washer	1	a. A.	-
1050	32429136000	Cover	1	a. A.	-
1070	30723055006	Nut	1	a. A.	-
1075	30234026008	Cable tie	2	a. A.	-
1080	43064023045	Fillister head screw	8	a. A.	-
1110	32217429060	Information sign	1	a. A.	-
5000	33901134040	Tool box ass.	1	a. A.	-
5010	30240247002	Bottle holder	1	a. A.	-
5020	32132022007	Pump	1	a. A.	-
5030	31414054008	Replacement hose	1	a. A.	-
5040	64201001000	Hook f. chip removal	1	a. A.	-
5050	32174008007	Lashing strap	1	a. A.	-
5080	30217332009	Centering pins	1	a. A.	-
5090	30217333003	Centering pins	1	a. A.	-
5110	63901037010	Contact and swarf protection	1	a. A.	-
5130	63901023002	QuickIN-adaptor	1	a. A.	-
5140	63901021014	QuickIN-adaptor	1	a. A.	-
5150	30217337002	Centering pins	1	a. A.	-
5160	30217338000	Centering pins	1	a. A.	-
5200	63202037010	Key-type drill chucks	1	a. A.	-
5205	62914004007	Chuck key	1	a. A.	-
5220	63901023011	Key-type drill chuck with QuickIN holder	1	a. A.	-
6000	32160003182	Lubricant tube 0,085 kg	1	a. A.	-
9000	34101166210	Operating instructions JCM 200Q/206Q	1	a. A.	-
9010	34151166000	List of spare parts JCM 200Q	1	a. A.	-

Bauart:  
Best.-Nr.:

JCM 200 Q (60Hz,120V)  
72703612360

7 270 36 - JCM 200 Q

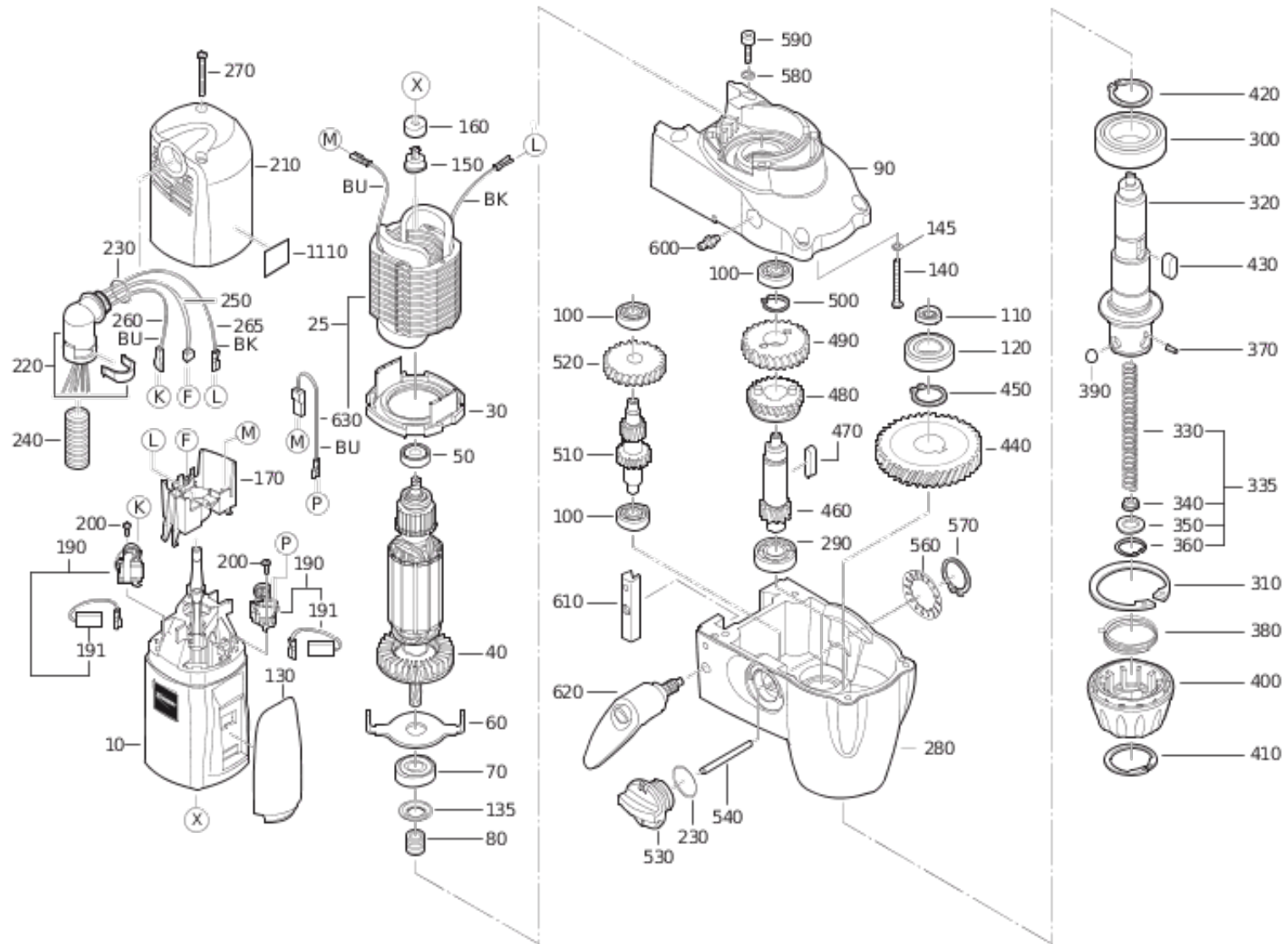

Bauart:  
Best.-Nr.:

JCM 200 Q (60Hz,120V)  
72703612360

7 270 36 - JCM 200 Q

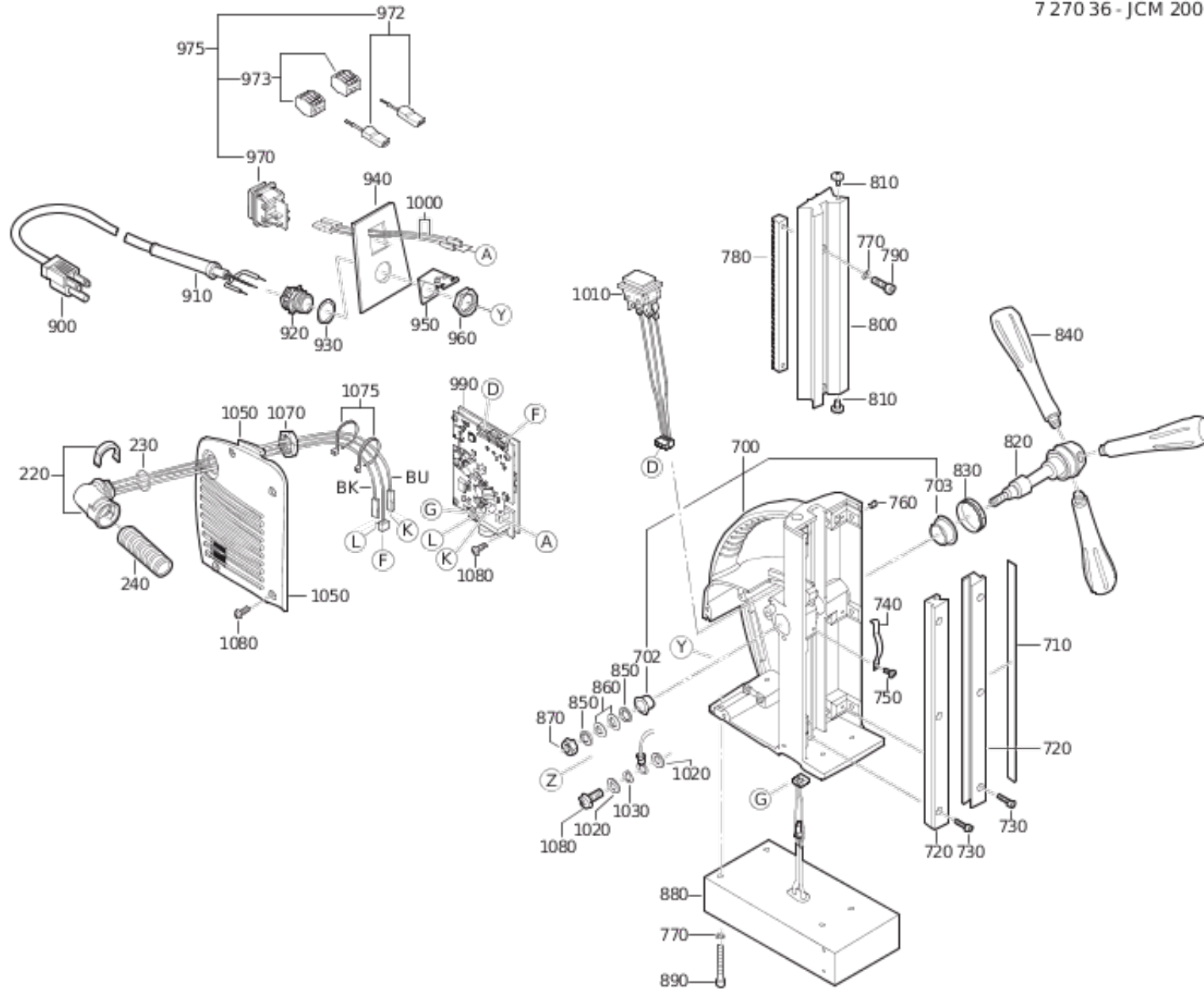

Bauart:  
Best.-Nr.:

JCM 200 Q (60Hz,120V)  
72703612360

7 270 36 - JCM 200 Q

