

AC-0782

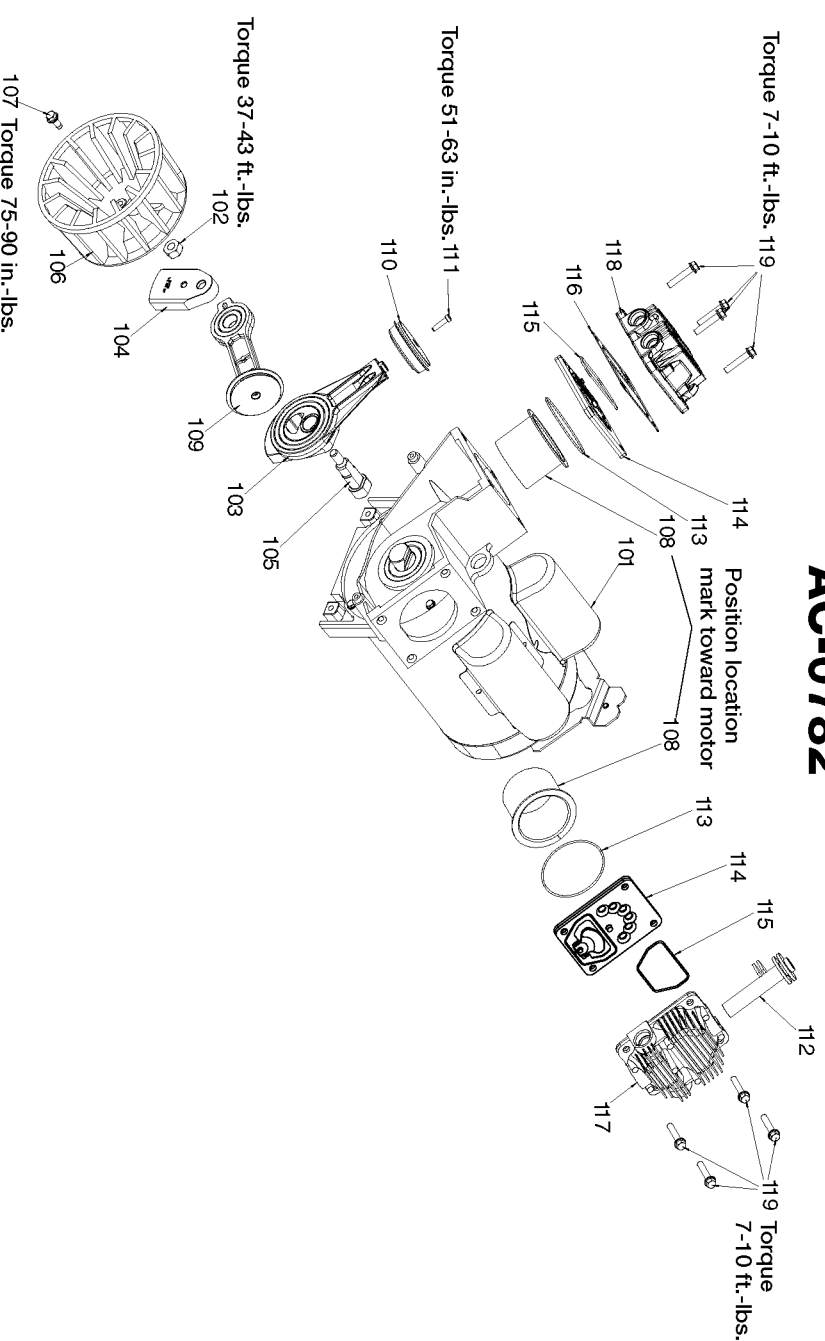

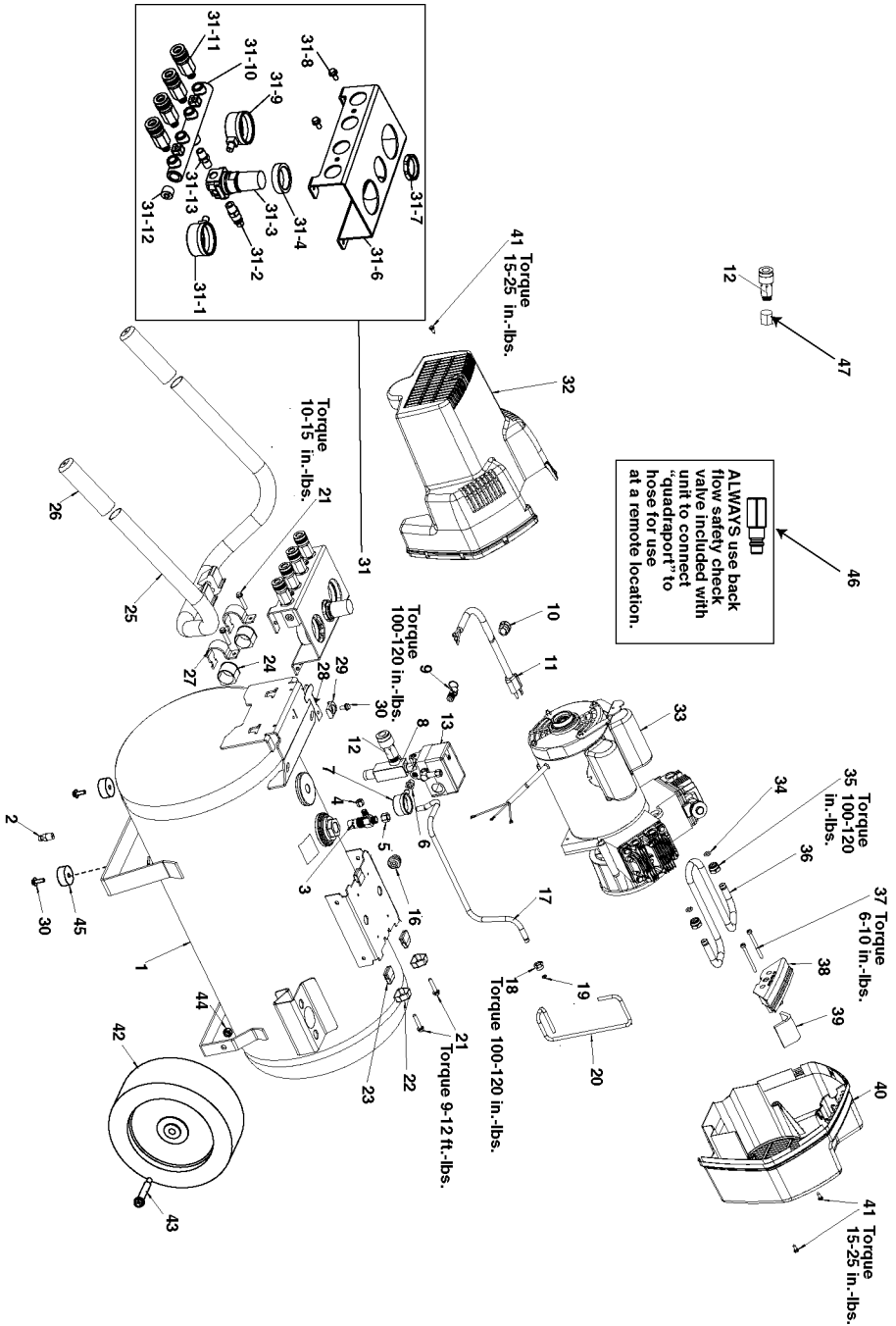

Parts List for CPFC2TV3520W Type 0

Item Number	Part Number	Description	Qty Required
1	000000-00	No Longer Available	1
2	A17038	DRAIN VALVE	1
3	A19712	VALVE CHECK 1/2NPT X	1
4	SSP-7811	ASSY NUT SLEEVE 1/4	1
5	SSP-7813	ASSY NUT SLEEVE 3/8	1
6	SSP-6021	BUSHING REDUCER 1/8-	1
7	D23019	GAUGE	1
8	D22849	STANDPIPE BRASS MALE	1
9	TIA-4200	VALVE SAFETY 200 .25	1
10	SSW-7482	CONNECTOR CONDUIT 3/	1
11	D21173	ASSY CORD POWER 10 S	1
12	D23066	BODY QC .375 UNIV .3	2
13	Z-D21136	SWITCH PRES 3PORT 14	1
16	438010040063	HEYCO BUSHINGS	1
16	SSW-7367	BUSHING STRAIN RELIE	1
17	000000-00	No Longer Available	1
18	SSP-7821-1	NUT .563-18 UNF HEX	1
19	SSG-3105	ORING 306/296ID 073/	1
20	D22165	TUBE PRESSURE RELIEF	1
21	SSF-990	SCREW .250-20X1.25 U	1
22	ACG-18	CUP SADDLE MOUNT	1
23	ACG-19	ISOLATOR 3 POINT MOU	1
24	D21190	BUSHING NYLON HANDLE	1
25	000000-00	No Longer Available	1
26	A17036	GRIP HANDLE HORZ WB	1
27	D21621	STRAP HANDLE HORZ WB	1
28	D22974	TAB LOCKING HANDLE H	1

Parts List for CPFC2TV3520W Type 0

Item Number	Part Number	Description	Qty Required
29	000000-00	No Longer Available	1
30	91895680	SCREW .250-20X.750 H	10
31	Z-D20158	GAUGE TANK 2 P-C 300	1
31	D21425	BLOCK MANIFOLD HORZ	1
31	A19513	BODY QC .250 IND .25	1
31	D21432	PLUG PIPE 3/8 HEX SO	2
31	N053094	NIPPLE	1
31	D21140	PLUG QC .375 IND .25	1
31	N008792	REGULATOR RPR KIT	1
31	D27256	REGULATOR 4PORT P1P2	1
31	D21479	SPACER REGULATOR	1
31	000000-00	No Longer Available	1
31	D20155	RING REGULATOR HI-FL	1
31	D21172	SCREW .250-20X.500 H	10
31	Z-D20157	GAUGE REGULATOR 2 P-	1
32	D21026	SHROUD REAR NS VERT	1
33	Z-D24959	ASSY PUMP 2STG TWV 1	1
34	AC-0781	O-RING .362ID X.103W	1
35	AC-0780	NUT .750-16 UNF HEX	1
36	AC-0802	TUBE INTERCONNECTING	1
37	SSF-554	SCREW #10-14X2.50 PA	10
38	D21028	COVER INTAKE MUFFLER	1
39	ACG-12	ELEMENT FILTER INTAK	1
40	D21030	SHROUD FRONT NS TWIN	1
41	ACG-408	ASSY FASTENER	1
42	D23067	WHEEL PNEUMATIC 10IN	1
43	D23574	BOLT .375-16X3.40 UN	1

Parts List for CPFC2TV3520W Type 0

Item Number	Part Number	Description	Qty Required
44	SSF-8080-ZN	NUT .375-16 UNC-2B H	1
45	D24721	KIT ISOLATOR W/SCREW	1
47	000000-00	No Longer Available	1
101	K-0298	KIT CAPACITOR	1
102	000000-00	No Longer Available	1
103	K-0649	KIT CONNECTING ROD H	1
104	AC-0793	ECCENTRIC OUTER 2 ST	1
105	AC-0794	ECCENTRIC PIN 2 STAG	1
106	ACG-22	FAN RADIAL 6.0 OD	1
107	39124607	SCREW .250-20X.625 H	10
108	KK-4835	KIT CONNECTING ROD L	1
108	K-0648	KIT COMP RING HP REP	1
109	A02743	KIT CONNECTING ROD	1
110	K-0648	KIT COMP RING HP REP	1
111	000000-00	No Longer Available	10
112	ACG-11	MUFFLER INTAKE 2 CYL	1
113	SSG-8156	ORING 2.759/2.719ID	1
114	Z-AC-0032	ASSY VALVE PLATE	1
115	ACG-45	ORING P/L HEAD	1
116	N015593	HEAD GASKET	1
117	AC-0805	HEAD MACHINING 1/2	1
118	AC-0784	HEAD MACHINE HIGH PR	1
119	AC-0798	SCREW .250-20X1.25 H	10
856	D21560	WARNING LABEL	1
856	000000-00	No Longer Available	1
856	N008806	LABEL HOT SURFACE TR	1
856	LA-2832	LABEL	1

Parts List for CPFC2TV3520W Type 0

Item Number	Part Number	Description	Qty Required
856	D21562	LABEL WARNING MANIFO	1
856	D21564	LABEL WARNING MANIFO	1
856	LA-2650-3	LABEL WARNING ENG/FR	1