

Tanaka

Parts Catalog

■

■

Chain Saw

Model: ECS-3500

FIG.1 ENGINE

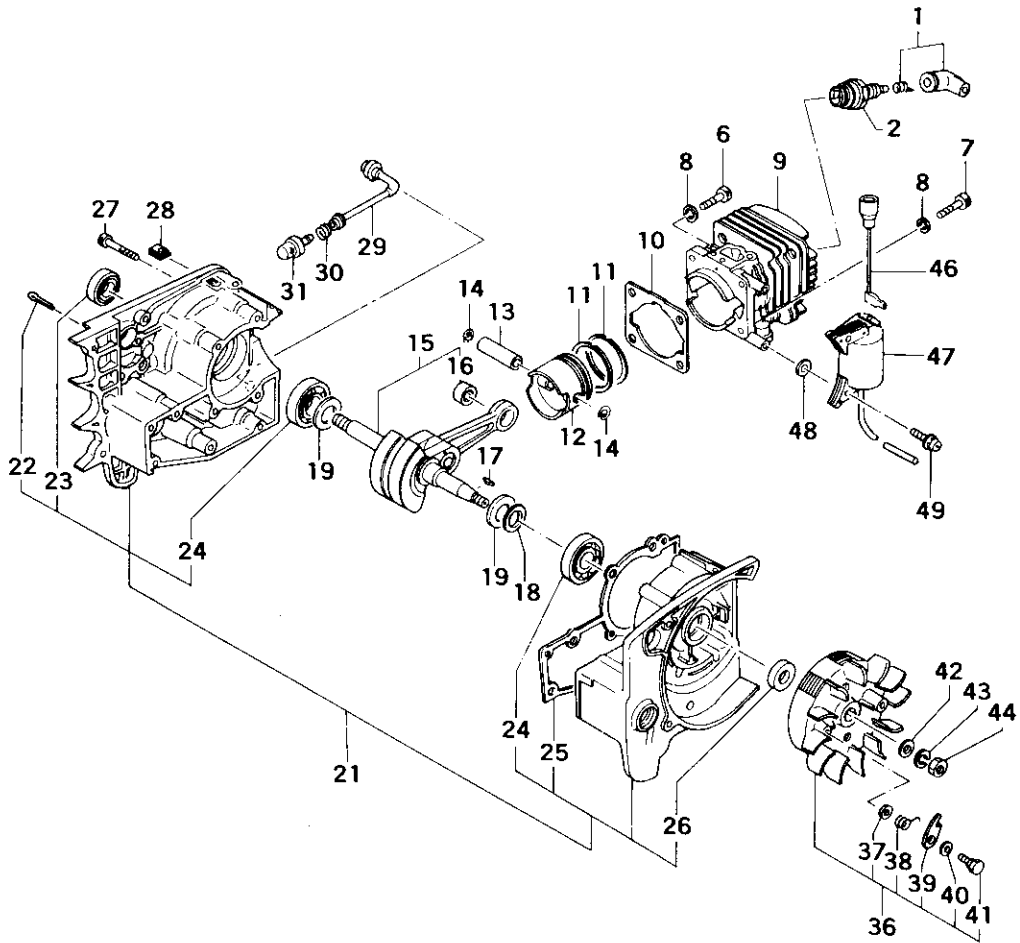

REF. NBR	PART NBR	PART NAME	QTY	SERIAL NBR	REMARKS
1-001	157-11666-900	SPARK PLUG CAP ASS'Y	1		
1-002	018-04075-200	SPARK PLUG CJ8Y	1		
1-006	990-51050-183	HEX. HOLE BOLT 5X18	2		
1-007	990-51050-223	HEX. HOLE BOLT 5X22	2		
1-008	992-10050-012	S.WASHER 5	4		
1-009	002-04075-201	CYLINDER	1		
1-010	017-04060-200	CYLINDER GASKET	1		
1-011	041-04000-200	PISTON RING	2		
1-012	031-01800-200	PISTON	1		
1-013	037-01400-200	PISTON PIN	1		
1-014	039-00000-201	PISTON PIN CIRCLIP	2		
1-015	048-04075-800	CRANK SHAFT COMP.	1		
1-016	999-62091-325	NEEDLE BEARING F-910	1		
1-017	068-10100-200	WOOD-RUFF KEY 3X13X4.5	1		
1-018	071-02007-200	CRANK SHAFT SHIM 0.05	V		
1-018	071-02007-210	CRANK SHAFT SHIM 0.10	V		
1-018	071-02007-220	CRANK SHAFT SHIM 0.15	V		
1-018	071-02007-230	CRANK SHAFT SHIM 0.20	V		
1-018	071-02007-240	CRANK SHAFT SHIM 0.30	V		
1-019	070-02401-201	CRANK SHAFT WASHER 15.2X22	2		
1-021	072-04069-912	CRANK CASE ASS'Y	1		
1-022	992-90200-104	SPLIT PIN 2X10	1		
1-023	999-66152-500	OIL SEAL 15257	1		
1-024	999-61620-200	BALL BEARING #6202	2		

-To be cont'd-

FIG.1 ENGINE

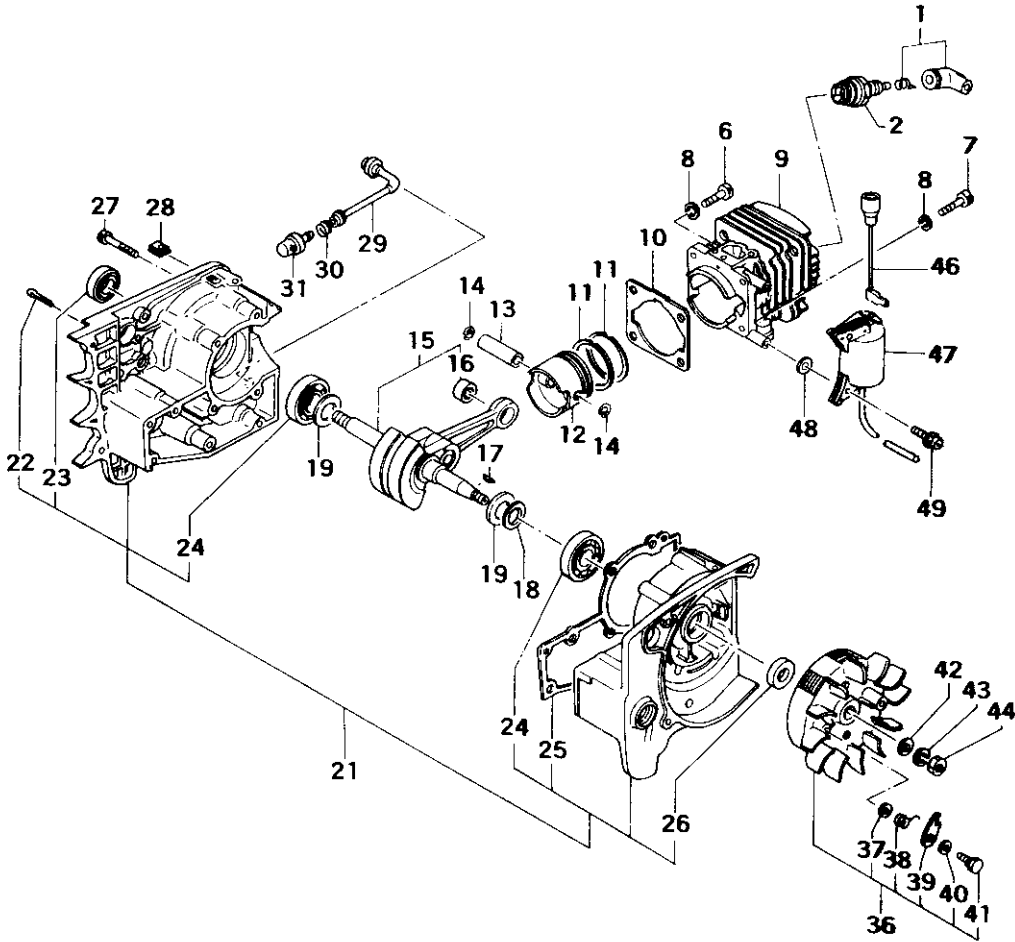

REF. NBR	PART NBR	PART NAME	QTY	SERIAL NBR	REMARKS
1-024	999-61620-200	BALL BEARING #6202	2		
1-025	090-04060-202	CRANK CASE GASKET	1		
1-026	999-66122-200	OIL SEAL 12227	1		
1-027	990-51050-303	HEX. HOLE BOLT 5X30	8		
1-028	488-32530-202	OIL ADJUST GROMMET	1		
1-029	505-32530-210	OIL PIPE B	1		
1-030	680-04019-210	CLIP 7	1		
1-031	488-32530-800	OIL FILTER BODY COMP.	1		
1-036	155-21719-900	MAGNETO ROTOR ASS'Y	1		
1-037	786-00601-200	STARTER PAWL WASHER	2		
1-038	790-01800-200	STARTER PAWL SPRING	2		
1-039	788-00601-203	STARTER PAWL	2		
1-040	822-00601-200	STARTER PAWL SHIM 0.8T	2		
1-041	793-10200-201	STEP BOLT	2		
1-042	992-01070-011	WASHER 7	1		
1-043	992-10070-012	S. WASHER 7	1		
1-044	066-01800-200	FLYWHEEL NUT	1		
1-046	173-04070-810	PRIMARY CORD COMP.	1		
1-047	167-21852-800	IGNITION COIL COMP.	1		
1-048	182-0186A-200	WASHER	2		
1-049	994-16040-226	SCREW 4X22/WS	2		

FIG.2 ENGINE COMPONENTS

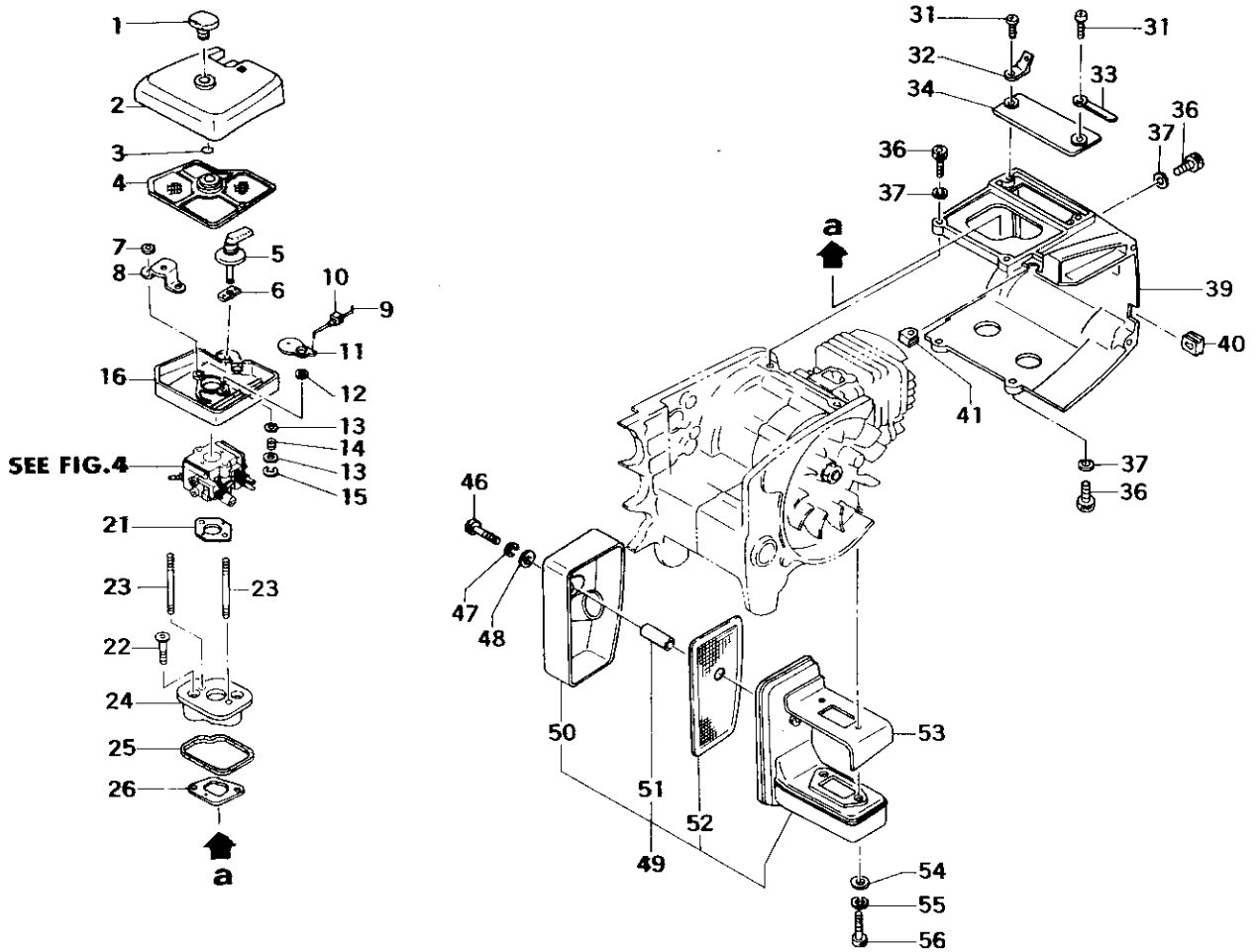

REF. NBR	PART NBR	PART NAME	QTY	SERIAL NBR	REMARKS
2-001	175-32530-800	CLEANER KNOB COMP.	1		
2-002	051-32530-211	CLEANER COVER	1		
2-003	999-67003-000	O-RING P-3	1		
2-004	420-04080-800	CLEANER ELEMENT COMP.	1		
2-005	704-32810-800	CHOKE BUTTON COMP.	1		
2-006	710-32600-201	CHOKE SET PLATE	1		
2-007	991-74050-010	U-NUT 5	2		
2-008	476-04080-200	BLOW OVER CHECK BOARD	1		
2-009	706-32530-200	CHOKE ROD	1		
2-010	707-32530-200	CHOKE ROD HOLDER RUBBER	1		
2-011	700-32800-211	CHOKE VALVE	1		
2-012	708-32350-200	CHOKE VALVE SHIM	1		
2-013	992-00060-011	SMALL WASHER 6	2		
2-014	308-36100-201	ADJUSTER SPRING A	1		
2-015	993-55040-001	STOP RING	1		
2-016	423-04080-200	CLEANER BODY	1		
2-021	402-11650-200	CARBURETOR GASKET	1		
2-022	990-52050-253	HEX. HOLE D.H. SCREW 5X25	2		
2-023	100-11600-210	STUD BOLT 5X53	2		
2-024	404-04080-800	CARBURETOR INSULATOR COMP.	1		
2-025	409-04080-200	CARBURETOR INSULATOR RUBBER	1		

-To be cont'd-

FIG.2 ENGINE COMPONENTS

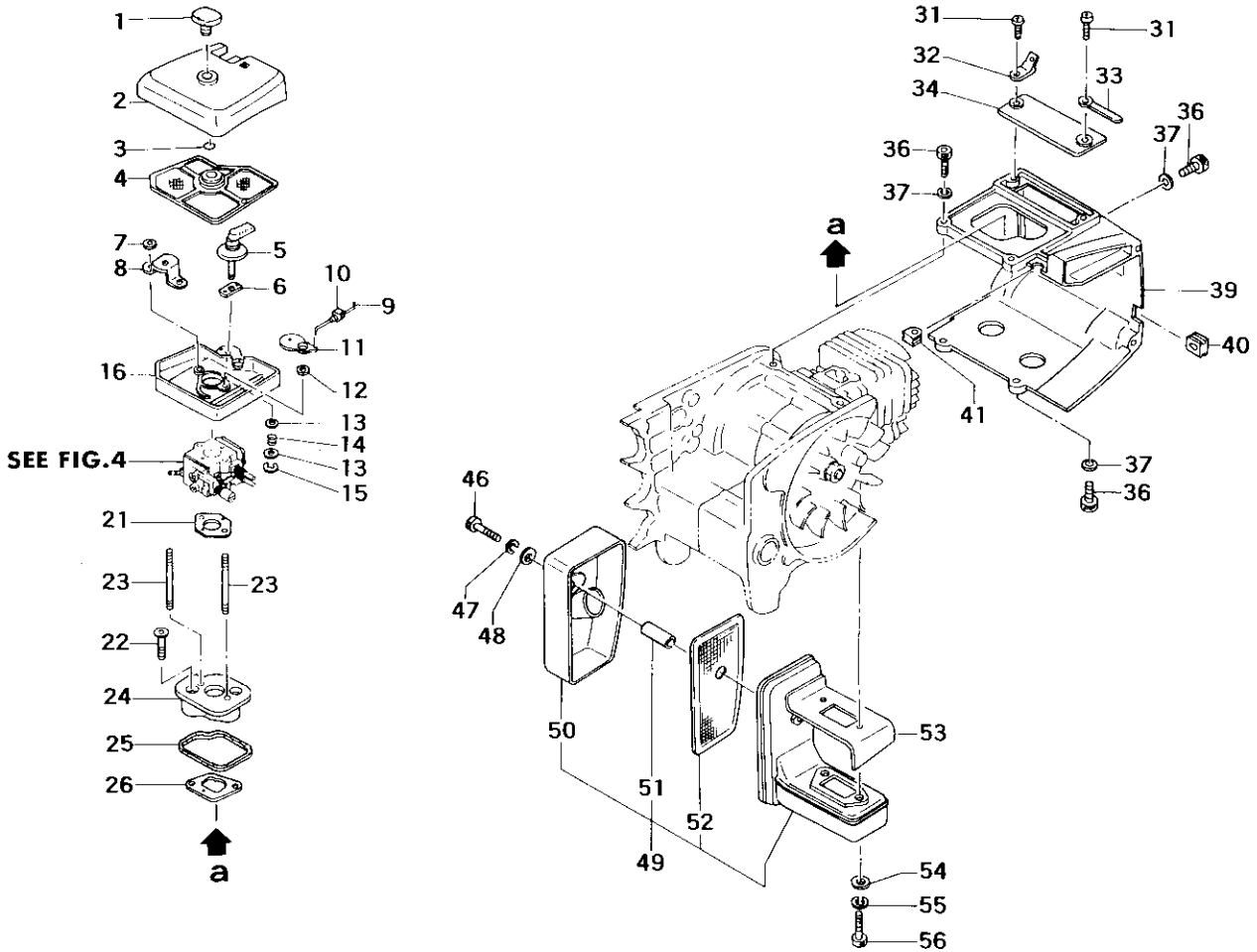

REF. NBR	PART NBR	PART NAME	QTY	SERIAL NBR	REMARKS
2-028	403-04080-201	INLET MANIFOLD GASKET	1		
2-031	990-11040-101	SCREW 4X10	2		
2-032	205-11800-201	TERMINAL TAB	1		
2-033	581-0077T-800	PIPE HOLDER COMP.	1		
2-034	188-32530-200	SHUTTER PLATE	1		
2-036	990-51050-153	HEX. HOLE BOLT 5X15	6		
2-037	992-00050-011	SMALL WASHER 5	6		
2-039	018-04079-200	CYLINDER COVER	1		
2-040	203-10000-200	PRIMARY CORD GROMMET	1		
2-041	203-08000-200	PRIMARY CORD GROMMET	1		
2-046	990-51050-353	HEX. HOLE BOLT 5X35	1		
2-047	992-10050-012	S. WASHER 5	1		
2-048	992-01050-011	WASHER 5	1		
2-049	705-04079-900	MUFFLER ASS'Y	1		
2-050	717-04075-800	MUFFLER BODY B COMP.	1		
2-051	740-01802-200	MUFFLER COLLAR	1		
2-052	732-04079-200	SPARK ARRESTOR	1		
2-053	737-04080-200	MUFFLER GASKET	1		
2-054	992-00050-011	SMALL WASHER 5	2		
2-055	992-10050-012	S. WASHER 5	2		
2-056	990-51050-353	HEX. HOLE BOLT 5X35	2		

FIG.3 RECOIL STARTER

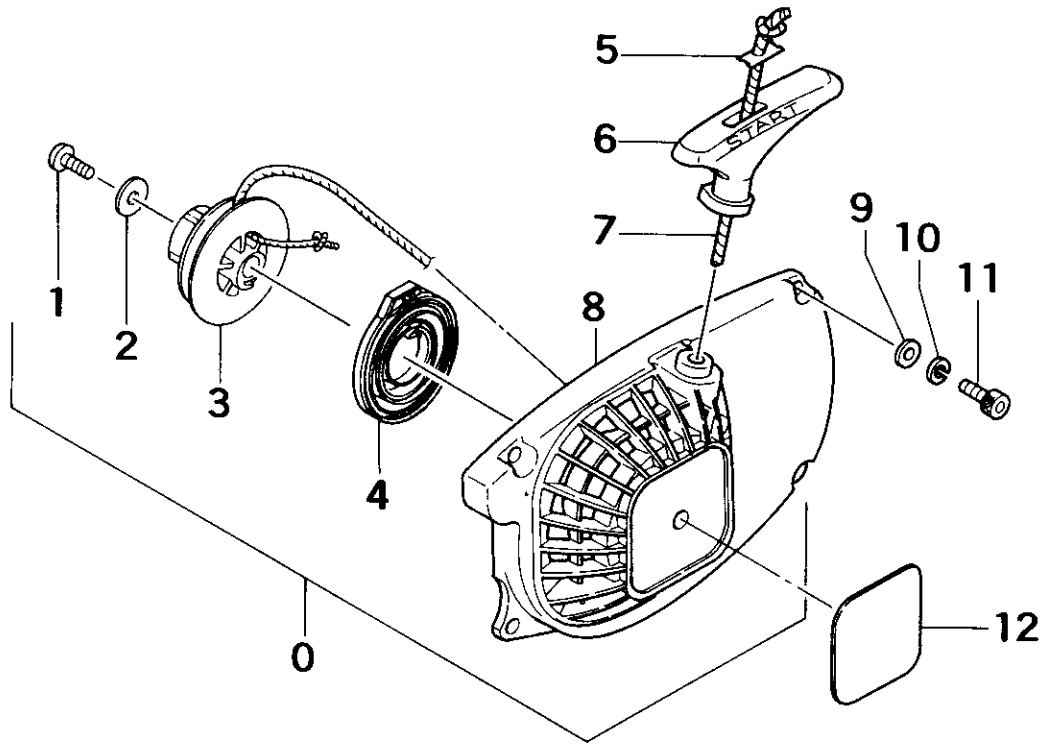

REF. NBR	PART NBR	PART NAME	QTY	SERIAL NBR	REMARKS
3-000	758-04079-900	RECOIL STARTER ASS'Y	1		
3-001	990-15050-126	SCREW 5X12	1		
3-002	786-04063-200	STARTER WASHER	1		
3-003	774-04063-800	STARTER ROPE REEL COMP.	1		
3-004	778-00601-900	RECOIL SPRING CASE ASS'Y	1		
3-005	795-04063-200	ROPE STOPPER	1		
3-006	785-04063-200	STARTER HANDLE	1		
3-007	783-04075-200	STARTER ROPE	1		
3-008	112-04079-800	FAN CASE COMP.	1		
3-009	992-00050-011	SMALL WASHER 5	4		
3-010	992-10050-012	S. WASHER 5	4		
3-011	990-51050-183	HEX. HOLE BOLT 5X18	4		
3-012	915-32529-200	STARTER MARK	1		

FIG.4 CARBURETOR

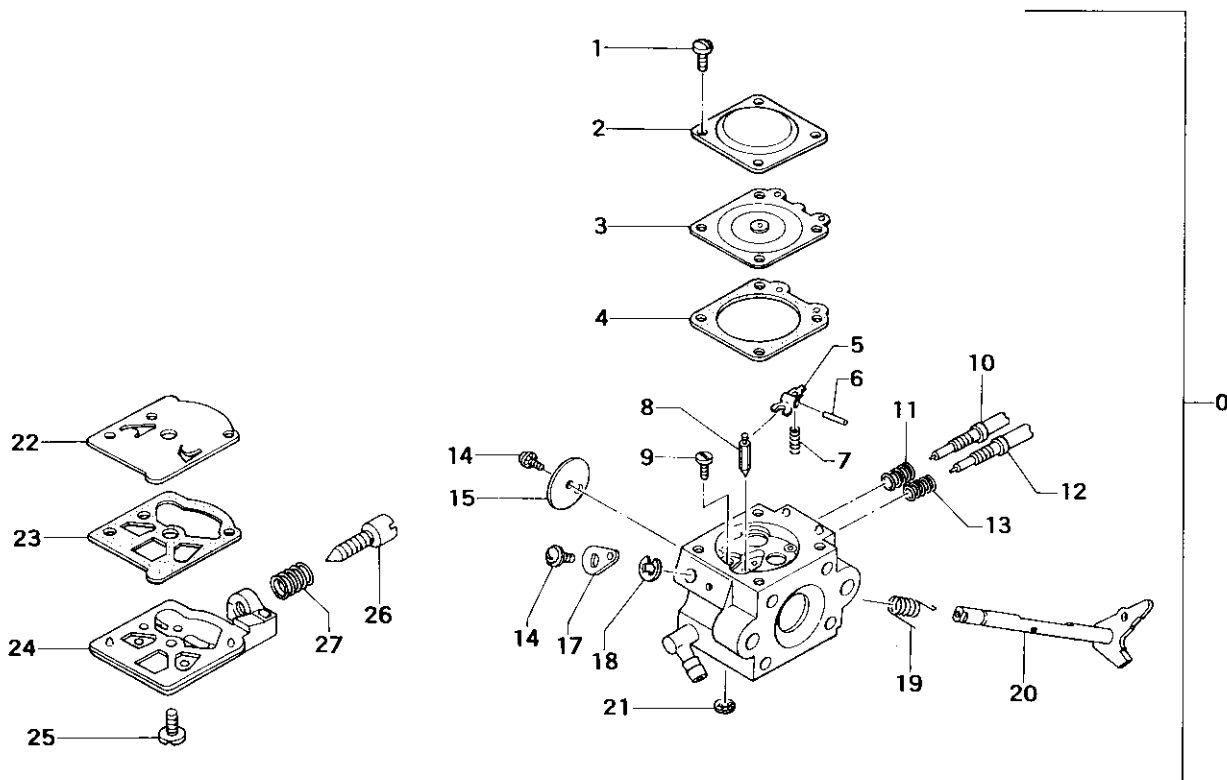

REF. NBR	PART NBR	PART NAME	QTY	SERIAL NBR	REMARKS
4-000	455-25019-901	CARBURETOR ASS'Y	1		
4-001	548-25012-200	SET SCREW	4		
4-002	476-25004-200	DIAPHRAGM COVER	1		
4-003	474-25001-800	METERING DIAPHRAGM COMP.	1		
4-004	475-25001-200	DIAPHRAGM GASKET	1		
4-005	473-25001-200	VALVE HINGE	1		
4-006	605-25001-200	HINGE PIN	1		
4-007	477-25003-200	VALVE SPRING	1		
4-008	603-25001-200	NEEDLE VALVE	1		
4-009	548-25001-200	HINGE PIN SET SCREW	1		
4-010	481-25016-200	LOW ADJUST SCREW	1		
4-011	623-25001-200	HIGH/LOW ADJUST SPRING	1		
4-012	480-25016-200	HIGH ADJUST SCREW	1		
4-013	485-25003-200	HIGH ADJUST SPRING	1		
5-014	487-25003-200	SHUTTER SCREW	2		
4-015	488-25001-200	THROTTLE VALVE	1		
4-017	491-25007-200	THROTTLE LEVER	1		
4-018	489-25007-200	STOP RING	1		
4-019	486-25015-200	THROTTLE SPRING	1		
4-020	464-25016-800	THROTTLE SHAFT COMP.	1		
4-021	578-25007-200	INLET SCREEN	1		
4-022	576-25006-200	PUMP DIAPHRAGM	1		
4-023	577-25007-200	PUMP GASKET	1		
4-024	575-25010-200	PUMP BODY	1		
4-025	514-25001-200	SET SCREW	1		
4-026	462-25016-200	IDLE ADJUST SCREW	1		
4-027	463-25006-200	IDLE ADJUST SPRING	1		

FIG.5 HANDLE

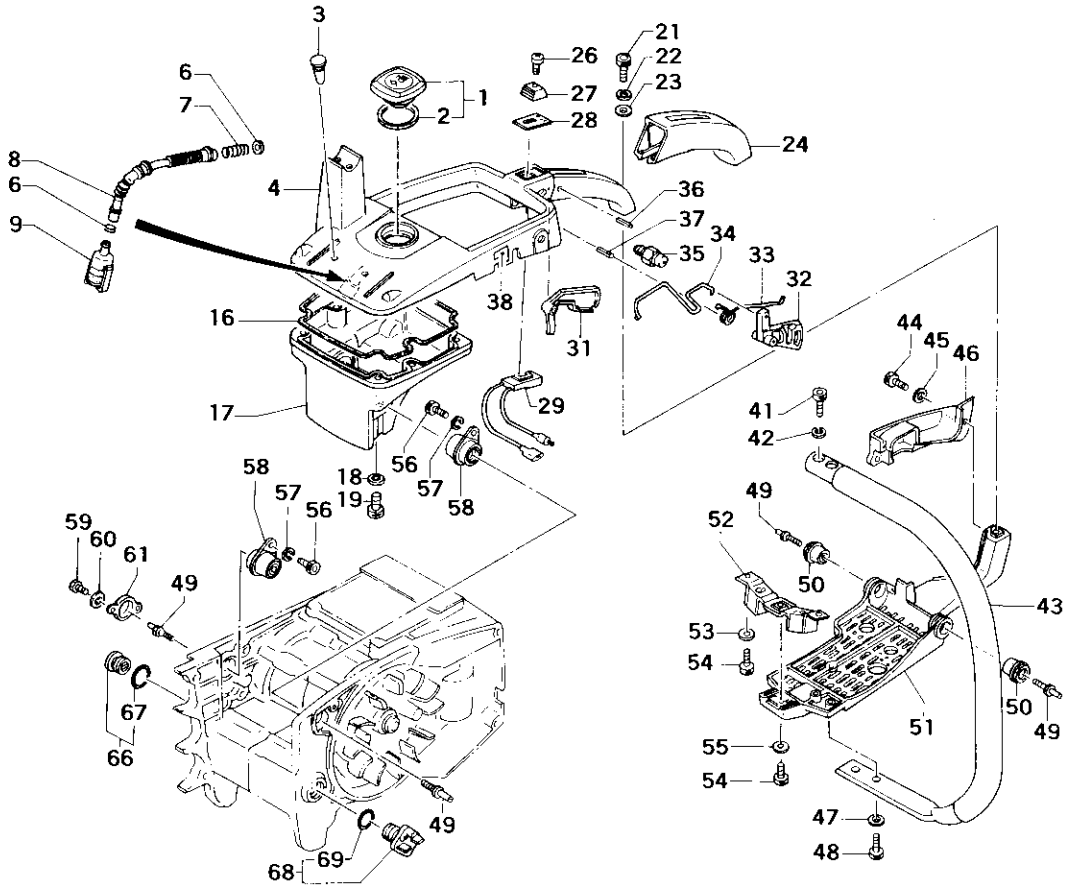

REF. NBR	PART NBR	PART NAME	QTY	SERIAL NBR	REMARKS
5-001	635-32600-912	TANK CAP ASS'Y	1		
5-002	642-11600-200	TANK CAP GASKET	1		
5-003	086-32530-200	GROMMET A	2		
5-004	010-32530-201	REAR HANDLE A	1		
5-006	880-04019-210	CLIP 7	2		
5-007	512-11600-200	PROTECTION COIL	1		
5-008	678-04060-210	RUBBER PIPE	1		
5-009	675-11610-901	PUMP FILTER BODY ASS'Y	1		
5-016	605-32530-200	TANK GASKET	1		
5-017	600-32530-200	TANK COVER	1		
5-018	992-10050-012	S.WASHER 5	4		
5-019	990-51050-153	HEX. HOLE BOLT 5X15	4		
5-021	990-51050-253	HEX. HOLE BOLT 5X25	1		
5-022	992-10050-012	S.WASHER 5	1		
5-023	992-00050-011	SMALL WASHER 5	1		
5-024	227-32530-200	REAR HANDLE GRIP	1		
5-026	994-31030-101	SCREW 3X10	1		
5-027	258-11600-200	BUTTON STOP	1		
5-028	925-32530-200	STOP BUTTON MARK	1		
5-029	170-04060-801	STOP BUTTON COMP.	1		
5-031	257-32530-201	SAFETY LEVER	1		
5-032	080-32530-200	THROTTLE LEVER	1		
5-033	061-32530-200	THROTTLE LEVER SPRING	1		
5-034	490-32530-201	THROTTLE ROD	1		
5-035	064-32530-800	PUSH PIN COMP.	1		
5-036	993-24004-180	SPRING PIN 4X18	1		
5-037	993-26005-254	SPRING PIN 5X25	1		

-To be cont'd-

FIG.5 HANDLE

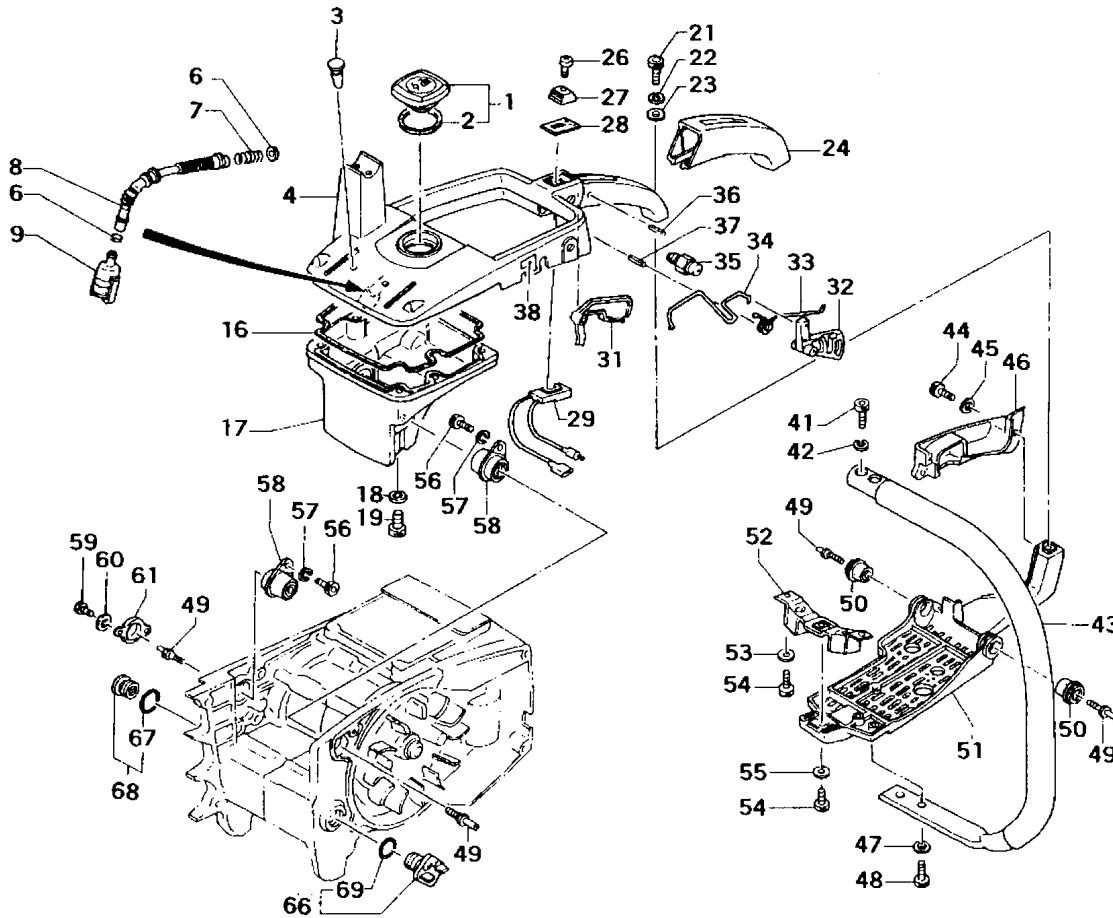

REF. NBR	PART NBR	PART NAME	QTY	SERIAL NBR	REMARKS
5-038	910-32600-200	CARBURETOR CAUTION MARK	1		
5-041	990-51050-253	HEX. HOLE BOLT 5X25	2		
5-042	992-01050-011	WASHER 5	2		
5-043	209-32525-800	FRONT HANDLE COMP.	1		
5-044	990-51050-153	HEX. HOLE BOLT 5X15	2		
5-045	992-00050-011	SMALL WASHER 5	2		
5-046	800-32530-800	REAR HAND GUARD COMP.	1		
5-047	992-01050-011	WASHER 5	2		
5-048	990-51050-153	HEX. HOLE BOLT 5X15	2		
5-049	295-32600-202	DAMPER SET BOLT A	4		
5-050	219-32600-821	DAMPER COMP.	2		
5-051	002-32530-201	ENGINE BASE	1		
5-052	266-32530-801	DAMPER B COMP.	1		
5-053	992-10050-012	S. WASHER 5	2		
5-054	990-51050-123	HEX. HOLE BOLT 5X12	3		
5-055	992-01050-011	WASHER 5	1		
5-056	990-51050-123	HEX. HOLE BOLT 5X12	2		
5-057	992-10050-012	S. WASHER 5	2		
5-058	219-32530-800	DAMPER COMP.	2		
5-059	990-51040-083	HEX. HOLE BOLT 4X8	2		
5-060	992-00040-011	SMALL WASHER 4	2		
5-061	224-32600-200	DAMPER CAP	1		
5-066	642-32800-902	OIL TANK CAP ASS'Y	1		
5-067	999-67020-000	O-RING P-20	1		
5-068	525-32530-900	OIL LEVEL CAP ASS'Y	1		
5-069	999-67020-000	O-RING P-20	1		

FIG.6 SIDE CASE

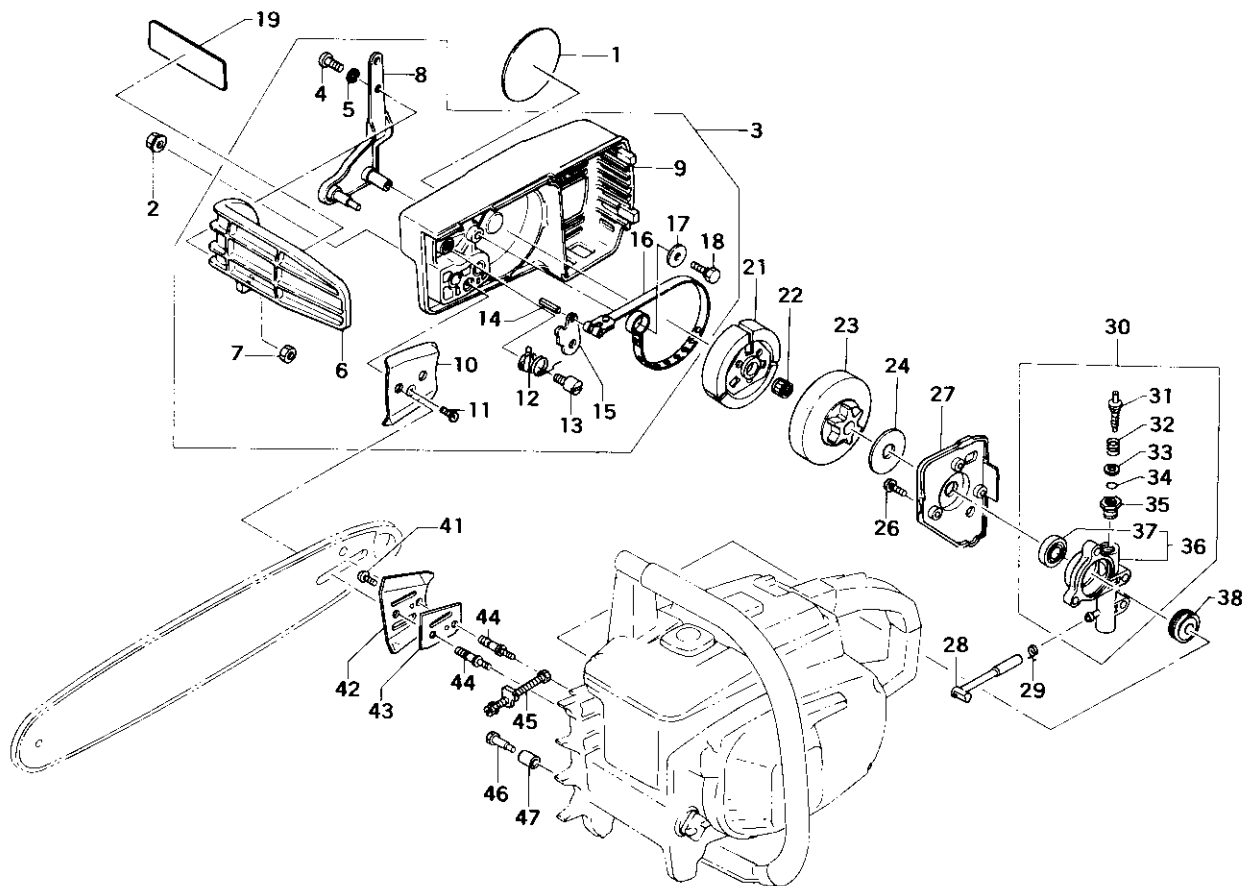

REF. NBR	PART NBR	PART NAME	QTY	SERIAL NBR	REMARKS
6-001	906-32529-200	NAME PLATE	1		
6-002	121-32530-200	CHAIN BAR CLAMP NUT	2		
6-003	040-32529-900	SIDE CASE ASS'Y	1		
6-004	990-51050-153	HEX. HOLE BOLT 5X15	2		
6-005	992-10050-012	S. WASHER 5	2		
6-006	380-32529-200	BRAKE HANDLE	1		
6-007	991-74050-010	U-NUT 5	2		
6-008	361-32750-801	BRAKE LEVER COMP.	1		
6-009	040-32529-800	SIDE CASE COMP.	1		
6-010	462-32525-200	GUIDE PLATE B	1		
6-011	993-41040-101	SCREW 4X10	1		
6-012	374-32367-210	BRAKE SPRING	1		
6-013	382-32750-200	STEP BOLT A	1		
6-014	993-24040-120	SPRING PIN 4X12	1		
6-015	373-32367-201	BRAKE ARM	1		
6-016	378-32529-800	BRAKE BAND COMP.	1		
6-017	368-32057-200	BRAKE SHAFT WASHER	1		
6-018	383-32367-210	STEP BOLT B	1		
6-019	907-3236F-200	CAUTION MARK	1		
6-021	287-04070-800	CLUTCH COMP.	1		
6-022	999-62101-301	NEEDLE BEARING 101310	1		
6-023	310-04079-200	CLUTCH HOUSING 3/8"	1		

-To be cont'd-

FIG.6 SIDE CASE

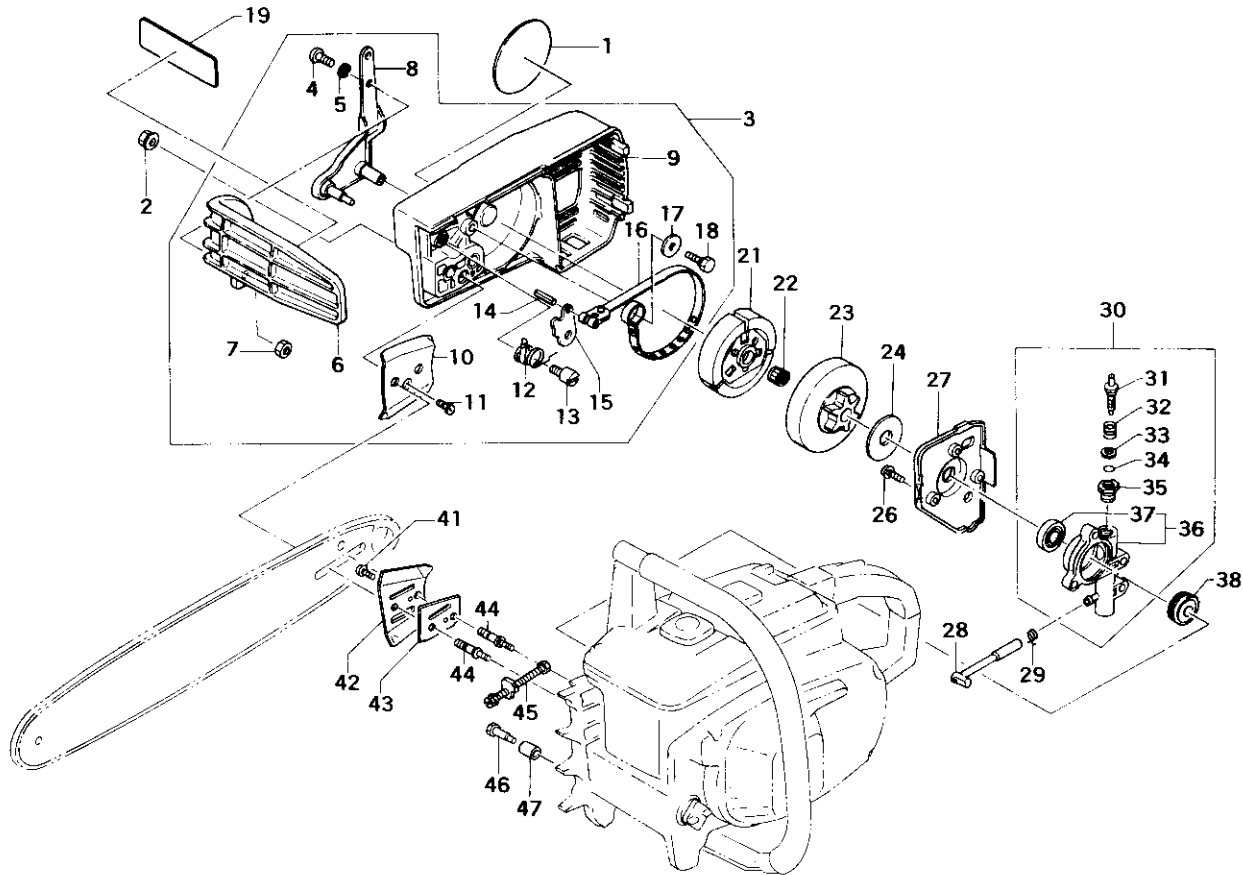

REF. NBR	PART NBR	PART NAME	QTY	SERIAL NBR	REMARKS
6-024	358-04050-201	CLUTCH WASHER	1		
6-026	990-11050-221	SCREW 5X22	3		
6-027	097-32530-800	OIL PUMP COVER COMP.	1		
6-028	515-32530-220	OIL PIPE A	1		
6-029	680-04080-200	CLIP 6.8	1		
6-030	088-32530-900	OIL PUMP CASE ASS'Y	1		
6-031	501-32530-200	OIL PUMP ADJUSTER	1		
6-032	502-32550-200	ADJUSTER SPRING	1		
6-033	992-01050-011	WASHER 5	1		
6-034	999-67005-000	O-RING P-5	1		
6-035	503-32550-200	OIL PUMP ADJUST CAP	1		
6-036	145-32550-800	OIL PUMP COMP.	1		
6-037	999-66132-420	OIL SEAL AC13246	1		
6-038	084-32350-200	SCREW GEAR	1		
6-041	990-11040-081	SCREW 4X8	1		
6-042	461-32530-200	GUIDE PLATE A	1		
6-043	466-32520-200	PLATE	1		
6-044	101-32530-200	CHAIN BAR STUD BOLT	2		
6-045	116-32382-900	TENSION ADJUSTMENT BOLT ASS'Y	1		
6-046	125-32530-200	CHAIN CATCHER	1		
6-047	700-18012-020	RUBBER PIPE	1		

FIG.7 TOOLS & OPTIONAL PARTS

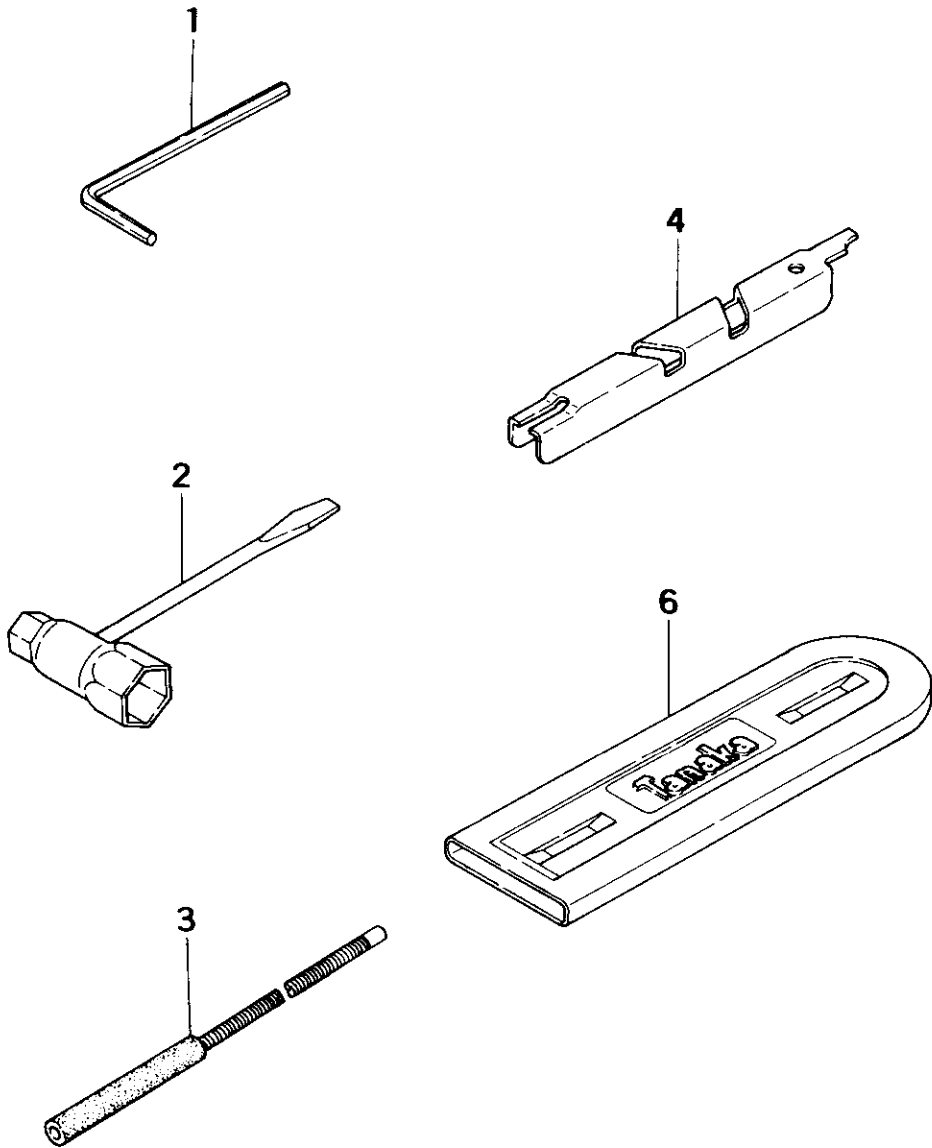

REF. NBR	PART NBR	PART NAME	QTY	SERIAL NBR	REMARKS
7-001	813-20000-200	HEX. WRENCH 4	1		
7-002	013-29323-501	COMBI. BOX SPANNER 10X19	1		
7-003	936-20000-900	FILE ASS'Y 5/32"	1		
7-004	930-32057-200	DEPTH GAUGE	1		
7-006	947-32055-202	CHAIN COVER 16"	1		