



This Manual is Bookmarked

## Owner's Manual Cold Saw

Models: FK350-2, FK350-2SX, FK350-4, FK350-4SX



*FK350*

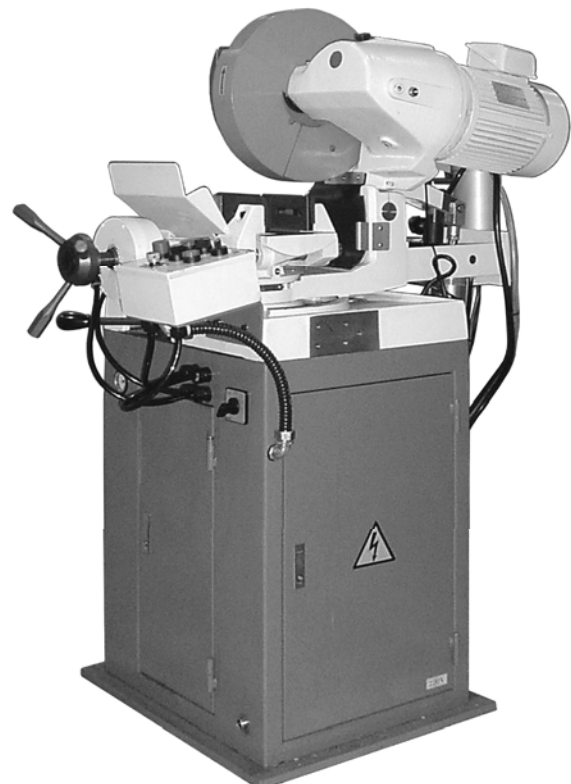

*FK350-SX*

**WMH TOOL GROUP**  
2420 Vantage Drive  
Elgin, Illinois 60124  
Ph.: 800-274-6848  
[www.wmhtoolgroup.com](http://www.wmhtoolgroup.com)

**Part No. M-FK350-2**  
Revision B 02/07  
Copyright © WMH Tool Group

## Head Assembly – FK350 & FK350-SX

Index No.	Part No.	Description	Size	Qty
1	FK350-201	Head Body		1
2	FK350-202	Spindle		1
3	FK350-203	Spindle Housing		1
4	FK350-204	Cutter Cap		1
5	FK350-205	Cutter Cap Pin		2
6	FK350-206	Stopper Ring		1
7	FK350-207	Spring Block		1
8	FK350-208	Tension Bolt		1
9	FK350-209	Belleville Spring		4
10	FK350-210	Taper Shaft		1
11	FK350-211	Worm Wheel		1
12	FK350-212	Worm Shaft		1
13	FK350-213	36NTGear		1
14	FK350-214	21NTGear		1
15	FK350-215	Collar A		1
16	FK350-216	Collar B		1
17	FK350-217	Bearing Cover		1
18	FK350-218	Handle		1
19	FK350-219	Handle Switch		1
21	BB-32007	Tapered Roller Bearing	#32007	1
22	BB-32008	Tapered Roller Bearing	#32008	1
23	FK350-223	Retainer		1
24	FK350-224	Tooth Washer		1
25	FK350-225	Retainer Nut		1
26	FK350-226	Retainer Nut		1
27	FK350-227	Tooth Washer		1
28	FK350-228	Tooth Washer		1
29	FK350-229	Retainer Nut		1
30	FK350-230	Flat Key	8x7x42mm	1
31	FK350-231	Flat Key	8x7x27mm	1
32	FK350-232	O-Ring		1
33	FK350-233	O-Ring	P8	1
34	FK350-234	Pin	5mm Dia. x 28	2
35	TS-1540071	Hex Nut	M10	2
36	FK350-236	Needle Roller Bearing	BK3026	1
37	BB-51206	Thrust Bearing	#51206	1
38	BB-6206	Deep Groove Ball Bearing	#6206	1
39	FK350-239	Motor 220V		1
	FK350-239-4	Motor 440V		1
40		Saw Blade		1
41	FK350-241	Stopper		1
42	FK350-242	Oil Sight Glass		1
43	TS-1504051	Socket Head Cap Screw M8x25		2
44	TS-1504041	Socket Head Cap Screw M8x20		4
45	TS-1504131	Socket Head Cap Screw M8x70		1
46	FK350-246	Oil Plug		1
47	TS-223E451	Socket Head Cap Screw M20x45		1
48	FK350-248	Oil Plug		1
49	FK350-249	Oil Plug		1
50	TS-1504061	Socket Head Cap Screw M8x30		2
51	TS-1492051	Hex Cap Screw M12x50		4
52	TS-154012	Hex Nut M20		1
53	TS-1540061	Hex Nut M8		1
54	TS-2361201	Lock Washer M20		1
55	TS-2361121	Lock Washer M12		4

# Head Assembly – FK350 & FK350-SX

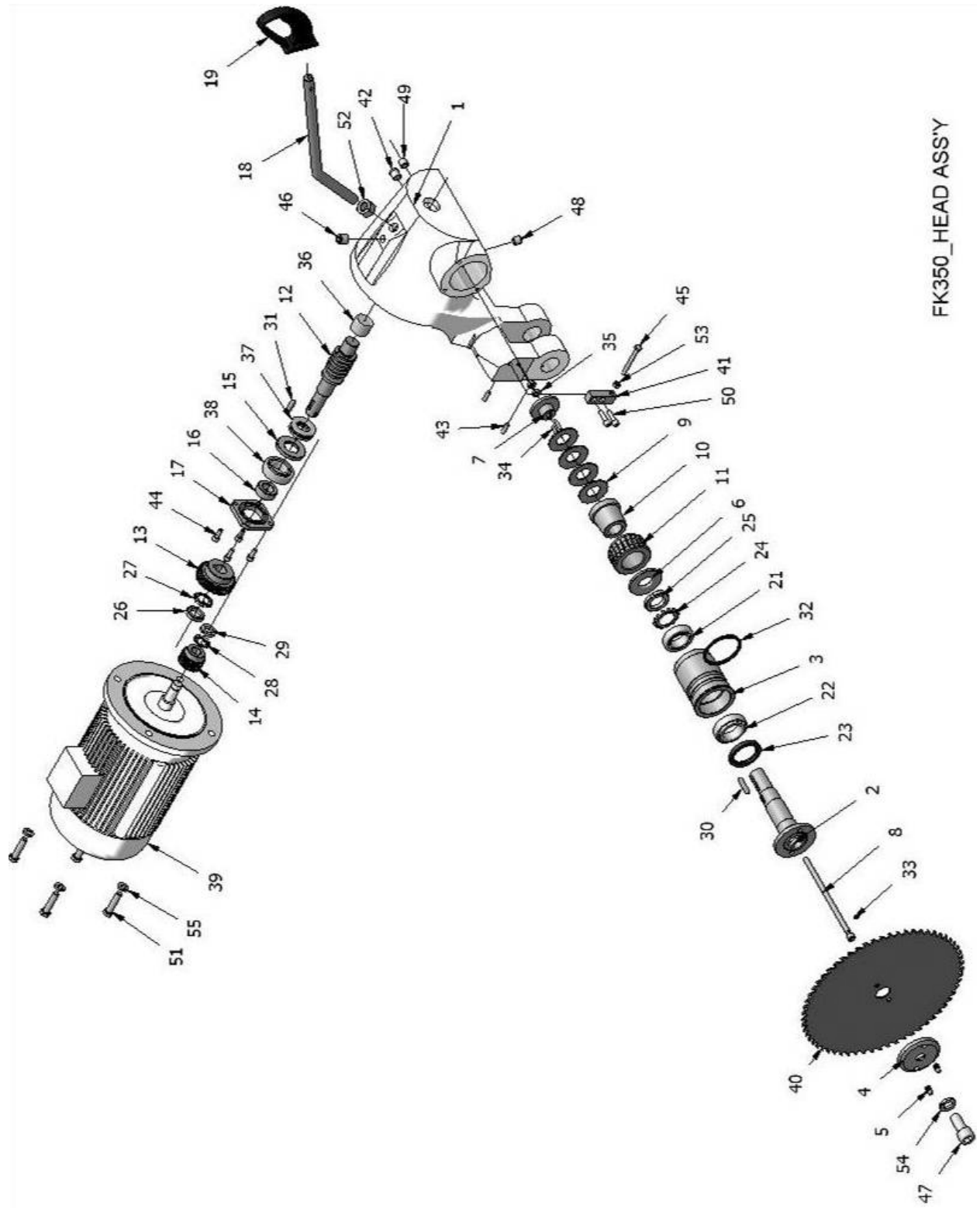

FK350\_HEAD ASS'Y

## Stock Stop Assembly

Index No.	Part No.	Description	Size	Qty
1	FK350-501	Block		1
2	FK350-502	Shaft		1
3	FK350-503	Stop Rod		1
4	FK350-504	Scale (Inch)		1
6	FK350-506	Handle	M8x30	2
7	FK350-505	Rivet		2

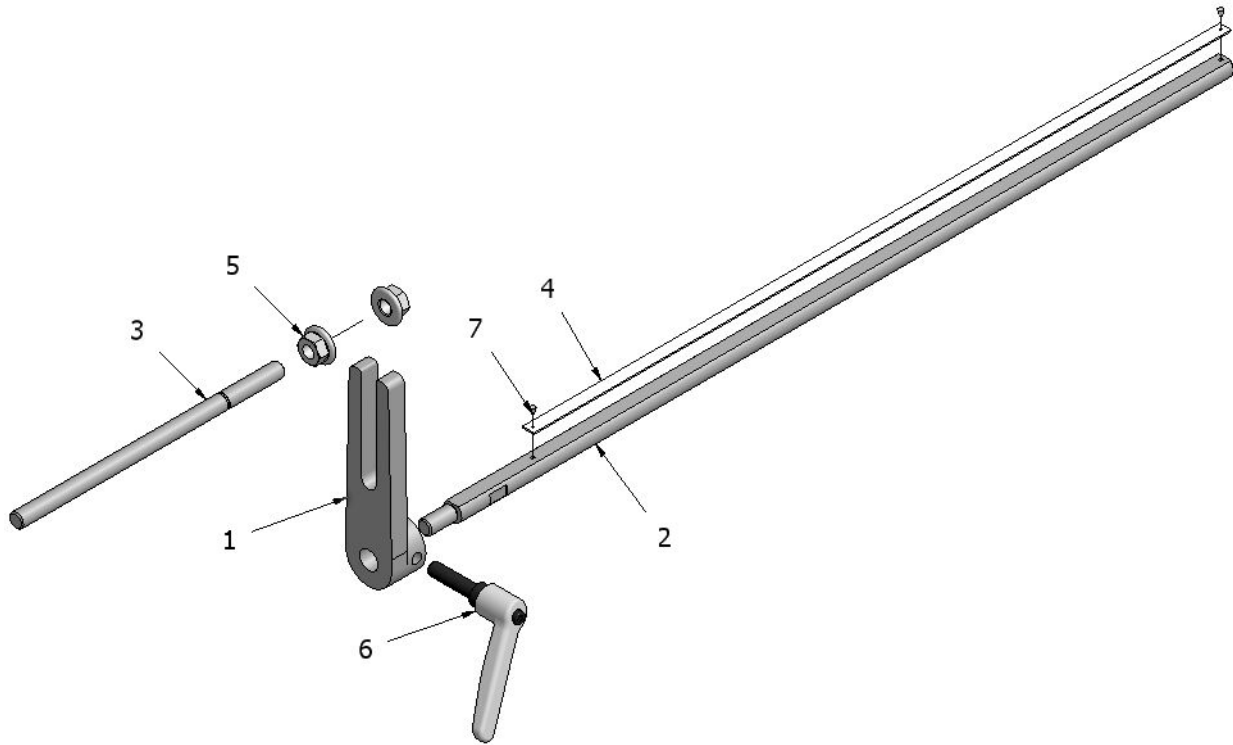

## Stand Assembly – FK350

Index No.	Part No.	Description	Size	Qty
1	FK350-601	Cabinet Stand		1
2	FK350-602	Coolant Pump		1
3	FK350-603	Cam Switch		1
4	FK350-604	Magnetic Switch		1
5	FK350-605	Overload Relay		1
6	FK350-606	Lighted Selector Switch		1
7	TS-1502051	Socket Head Cap Screw	M5x20	4
8	TS-1551031	Lock Washer	M5	4
9	FK350-609	Cable Lock		3
10	FK350-610	Rear Cover		1
11	TS-1503021	Socket Head Cap Screw	M6x10	4
12	FK350-612	Tapered Plug	PT1/4	1
13	FK350-613	Coolant Gauge		1
14	TS-1502051	Socket Head Cap Screw	M5x20	2

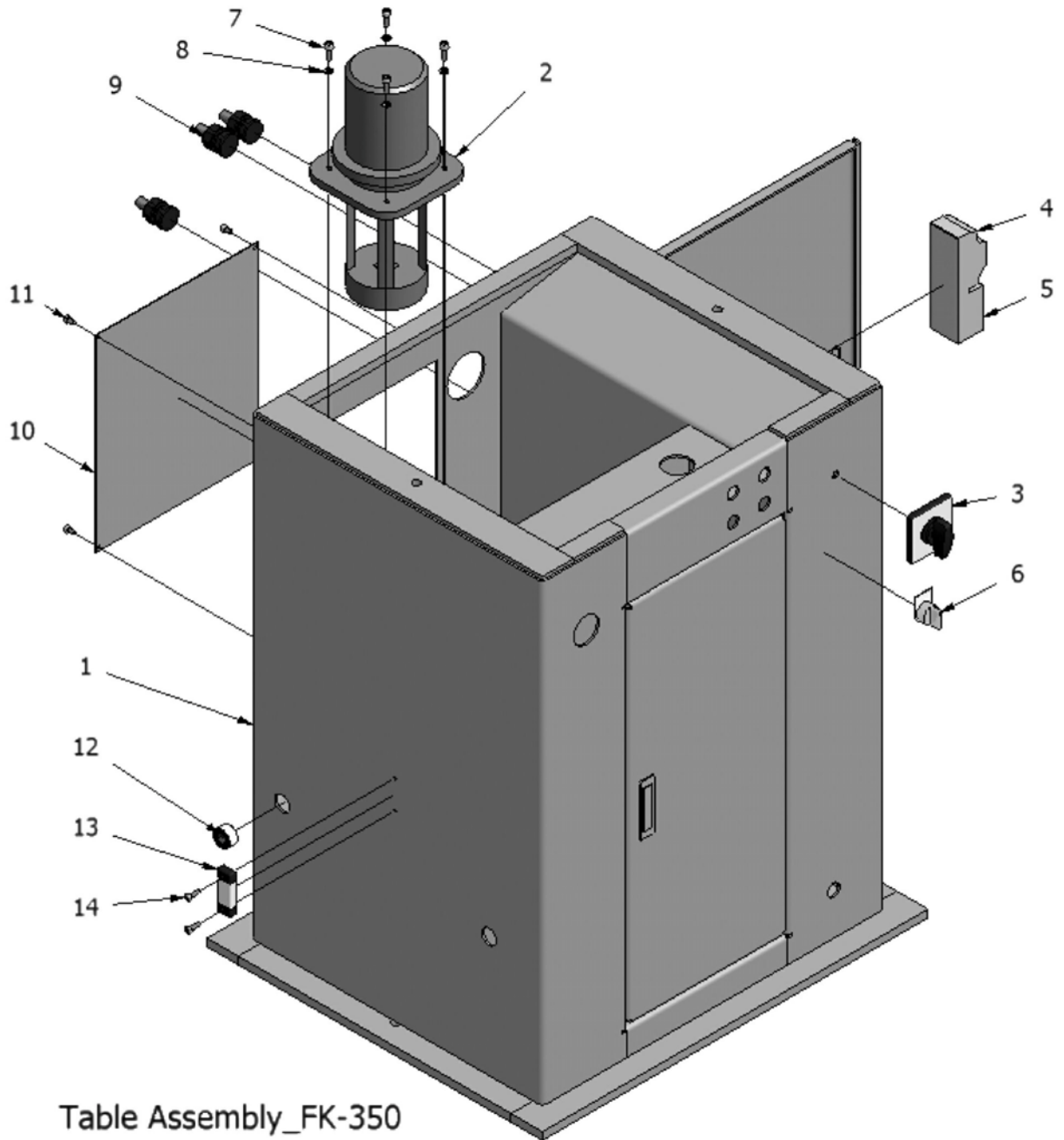
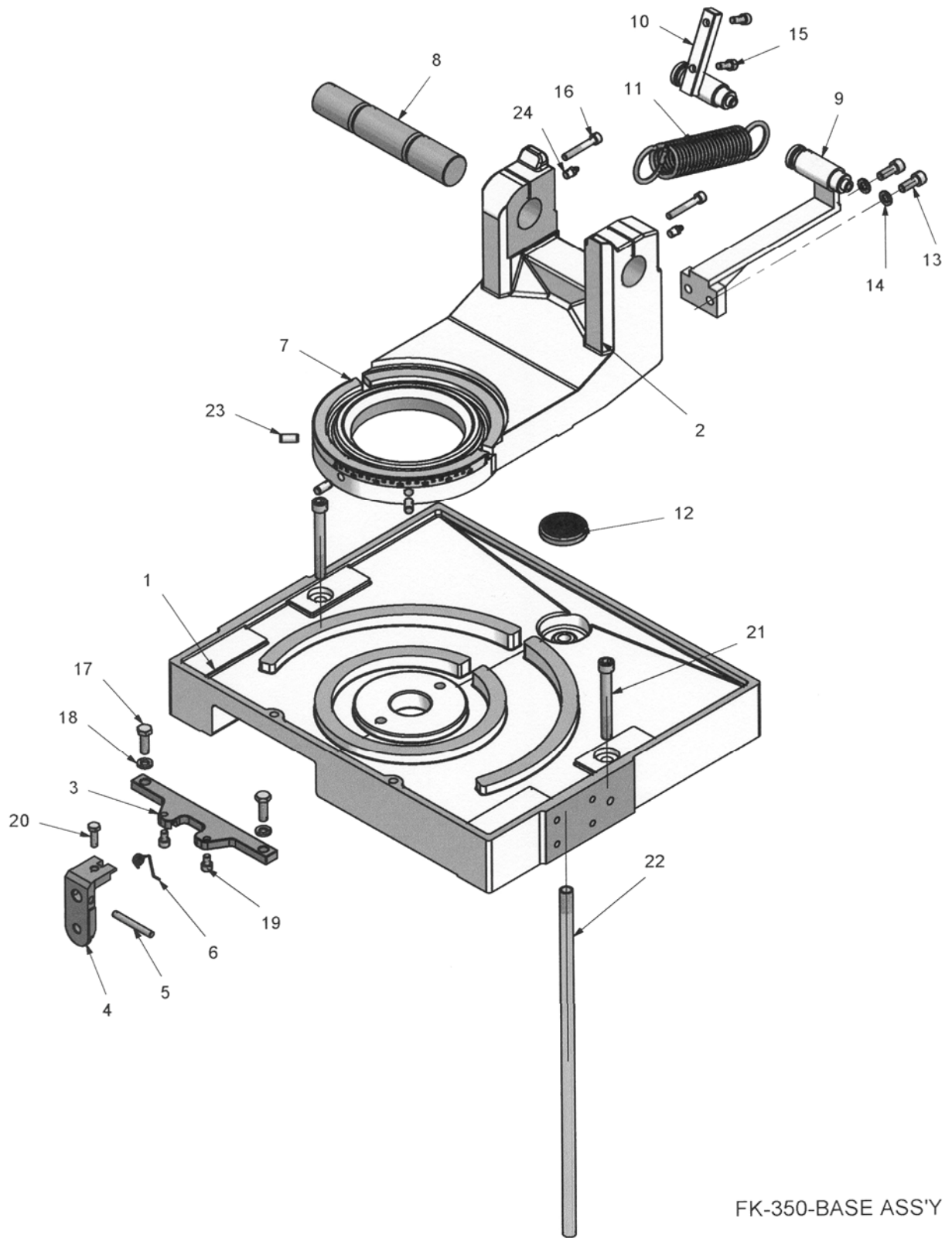

Table Assembly\_FK-350

## Base Assembly – FK350

Index No.	Part No.	Description	Size	Qty
1	FK350-101	Base		1
2	FK350-102	Hinge Body		1
3	FK350-103	Locking Mount		1
4	FK350-104	Release Handle		1
5	FK350-105	Pin		1
6	FK350-106	Coil Spring		1
7	FK350-107	Scale		1
8	FK350-108	Pivot Shaft		1
9	FK350-109	Spring Bracket A		1
10	FK350-110	Spring Bracket B		1
11	FK350-111	Return Spring		1
12	FK350-112	Chip Screen		1
13	TS-1505031	Socket Head Cap Screw	M10x25	2
14	TS-1551071	Lock Washer	M10	2
15	TS-1504041	Socket Head Cap Screw	M8x20	2
16	TS-1504101	Socket Head Cap Screw	M8x50	2
17	TS-1491041	Hex Cap Screw	M10x30	2
18	TS-2361101	Lock Washer	M10	2
19	TS-1504021	Socket Head Cap Screw	M8x12	2
20	TS-1490041	Hex Cap Screw	M8x25	1
21	TS-223A911	Socket Head Cap Screw	M12x100	2
22	FK350-122	Pipe		1
23	FK350-123	Pin	10mm Dia. x 22	3
24	FK350-124	Grease Fitting	PT 1/8	2

# Base Assembly – FK350



FK-350-BASE ASS'Y

## Manual Vise Assembly – FK350

Index No.	Part No.	Description	Size	Qty
1	FK350-301	Base		1
2	FK350-302	Vise Jaw		2
3	FK350-303	Tip		1
4	FK350-304	Vise Screw		1
5	FK350-305	Jaw Insert A (Steel, Smooth)		2
	FK350-305ST	Jaw Insert A (Steel, Serrated)		2
6	FK350-306	Jaw Insert B (Steel, Smooth)		2
	FK350-306ST	Jaw Insert B (Steel, Serrated)		2
7	FK350-307	Guide Rod		2
8	FK350-308	Handle Hub		1
9	FK350-309	Handle		3
10	FK350-310	Filling Block		1
12	FK350-312	Cap		1
13	FK350-313	Setting Screw		1
14	FK350-314	Hex Nut	M20x1.5P	1
15	FK350-315	Cover		1
16	FK350-316	Tension Handle		1
17	FK350-317	Tension Nut		1
18	FK350-318	Pressure Plate		1
19	FK350-319	Scale Centering		1
20	FK350-320	Pin	10mm Dia. x 30	2
21	FK350-321	Retainer		2
22	TS-1505051	Socket Head Cap Screw	M10x35	4
23	TS-1540071	Hex Nut	M10	4
25	TS-1502031	Socket Head Cap Screw	M5x12	2
26	TS-1550031	Flat Washer	M5	2
27	TS-1490091	Hex Cap Screw	M8x50	3
28	TS-1540061	Hex Nut	M8	3
29	TS-1505041	Socket Head Cap Screw	M10x30	2
30	TS-1505011	Socket Head Cap Screw	M10x16	2
31	FK350-331	Rivet	2mm Dia. x 4	2



# Manual Vise Assembly – FK350

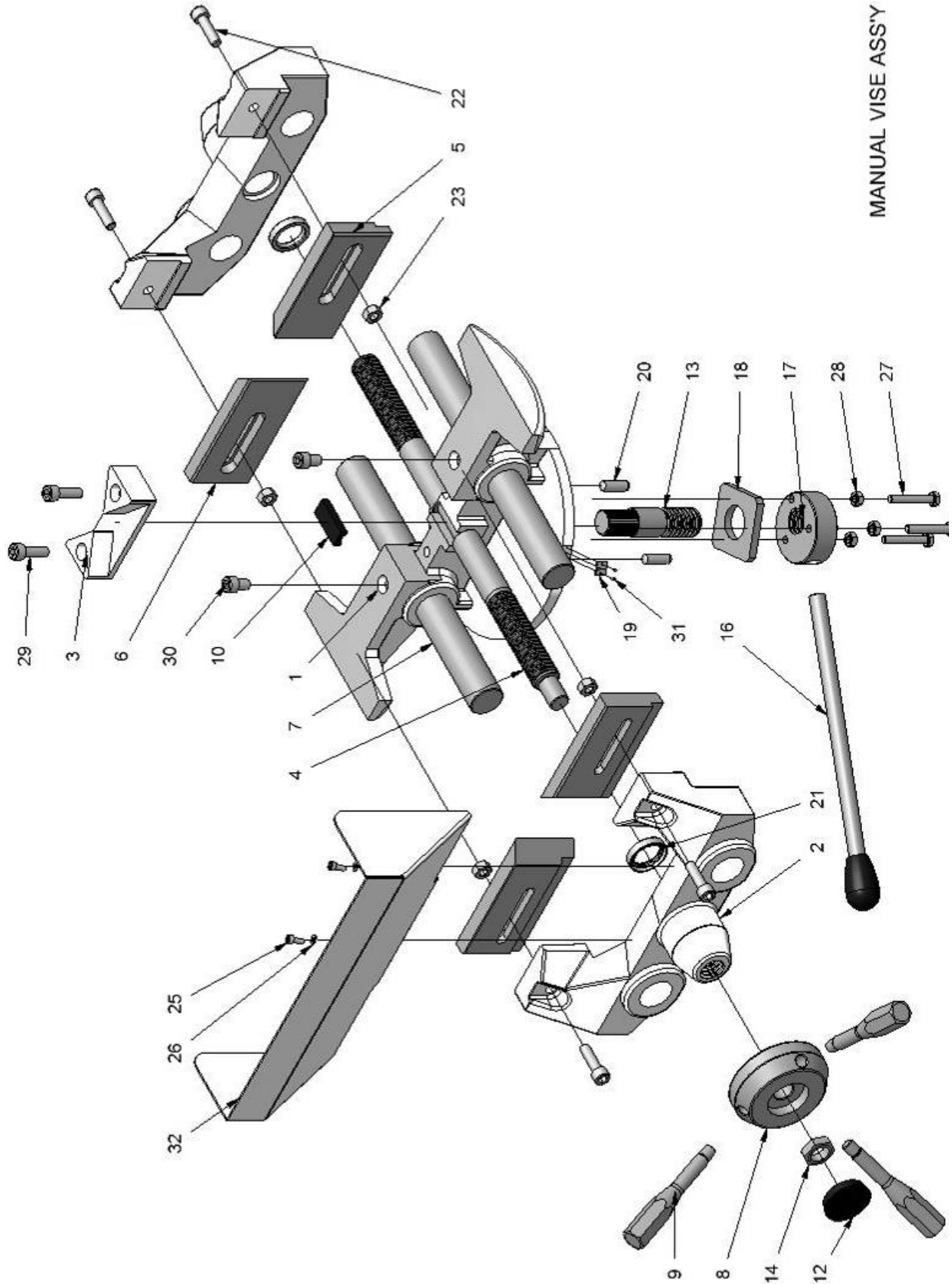

## Guard Assembly – FK350 & FK350-SX

Index No.	Part No.	Description	Size	Qty
1	FK350-401	Guard A		1
2	FK350-402	Guard B		1
3	FK350-403	Guard C		1
4	FK350-404	Link A		1
5	FK350-405	Nylon Spacer A		6
6	FK350-406	Nylon Spacer B		3
7	FK350-407	Nylon Spacer C		2
8	FK350-408	Link B		1
9	FK350-409	Link C		1
10	FK350-410	Link Ring		1
11	FK350-411	Link Pin		1
12	FK350-412	Link Bracket		1
13	FK350-413	Link D		1
14	FK350-414	Link D Ring		1
15	TS-1504031	Socket Head Cap Screw	M8x16	3
16	TS-1550061	Flat Washer	M8	3
17	TS-1504061	Socket Head Cap Screw	M8x30	2
18	TS-1551061	Lock Washer	M8	2
19	TS-1521021	Set Screw	M4x6	1
20	FK350-420	Snap Ring	S48	1
21	FK350-421	Snap Ring	S10	2
22	FK350-422	Bushing		1
23	FK350-423	Knob	M8x30	1
24	FK350-424	Shut off Valve		1
25	FK350-425	Hose Band		1
26	FK350-426	Hose		1

# Guard Assembly – FK350, FK350-2SX

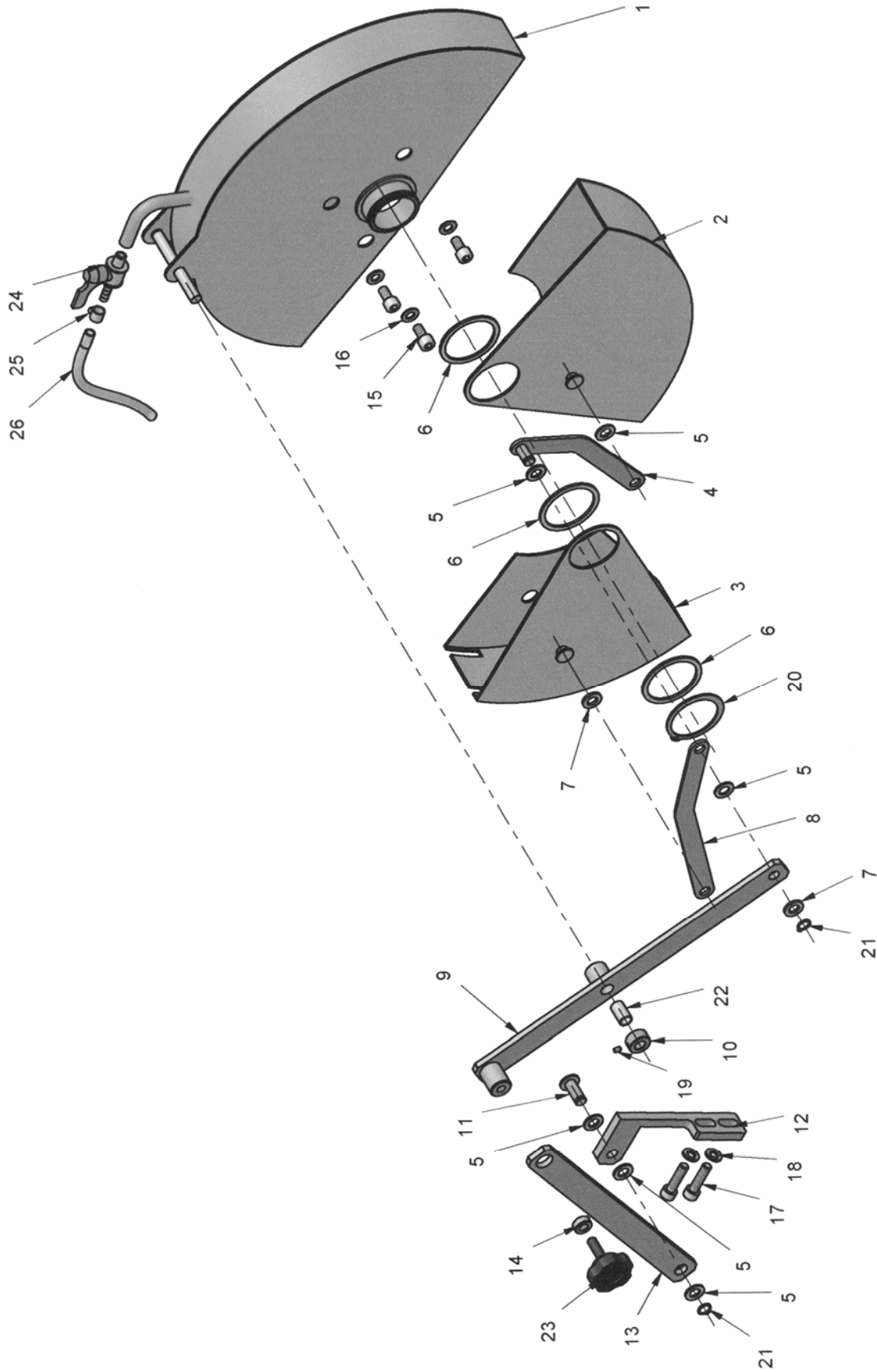

FK-350, FK-350-2SX\_GUARD ASS'Y

## In-Feed Table Assembly

Index No.	Part No.	Description	Size	Qty
1	FK350-701	Bracket		1
2	FK350-702	Stand		1
3	FK350-703	Leveling Foot		2
4	TS-154010	Hex Nut M16		2
5	FK350-705	Angle Rail		2
6	FK350-706	Base A		1
7	FK350-707	Base B		1
8	TS-1491041	Hex Cap Screw	M10x30	8
9	TS-1491061	Hex Cap Screw	M10x40	2
10	TS-1491121	Hex Cap Screw	M10x70	2
11	TS-2361101	Lock Washer	M10	12
12	TS-1540071	Hex Nut	M10	16
13	FK350-713	Roller		6
14	FK350-714	Roller Bracket		12
15	TS-1502021	Socket Head Cap Screw	M5x10	12
16	FK350-716	Cover A		2
17	FK350-717	Cover B		5
18	TS-1533032	Pan Head Screw	M5x10	7

### In & Out Supply Track Assembly

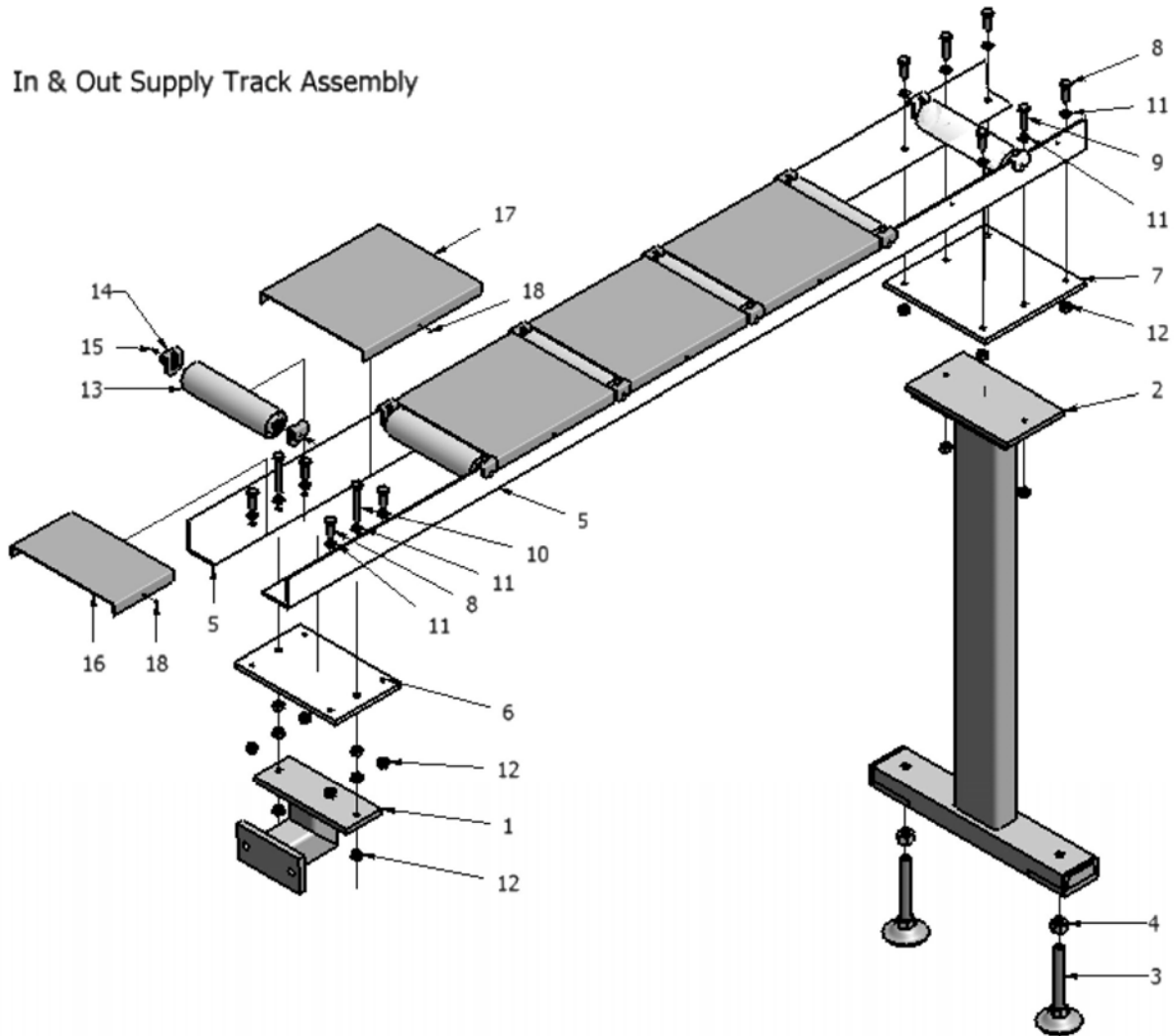

## Out-Feed Table

1	FK350-801	Guide Block		EA
2	FK350-802	Guide Rail		EA
3	TS-1502051	Socket Head Cap Screw	M5x20	EA
4	FK350-804	Stopper Base		EA
5	TS-1502051	Socket Head Cap Screw	M5x20	EA
6	FK350-806	Connecting Plate		EA
7	TS-1502071	Socket Head Cap Screw	M5x30	EA
8	FK350-808	Lock Block A		EA
9	FK350-809	Lock Block B		EA
10	FK350-818	Spring		EA
11	FK350-811	Stopper		EA
12	TS-1503051	Socket Head Cap Screw	M6x20	EA
13	FK350-813	Stopper Pad		EA
14	TS-1502041	Socket Head Cap Screw	M5x16	EA
15	FK350-815	Scale Indicator		EA
16	FK350-816	Rivet		EA
17	FK350-817	Inch Scale		EA
18	FK350-810	Handle		EA

### Out Line Track Scale Stopper Assembly

