

SN883RH2

EXPLODED
VIEW AND SPARE PARTS LIST

SCHEMA ECLATE ET LISTE DES
PIECES DE RECHANGE

DESPIECE DE LA MAQUINA Y LISTA
DE RECAMBIOS

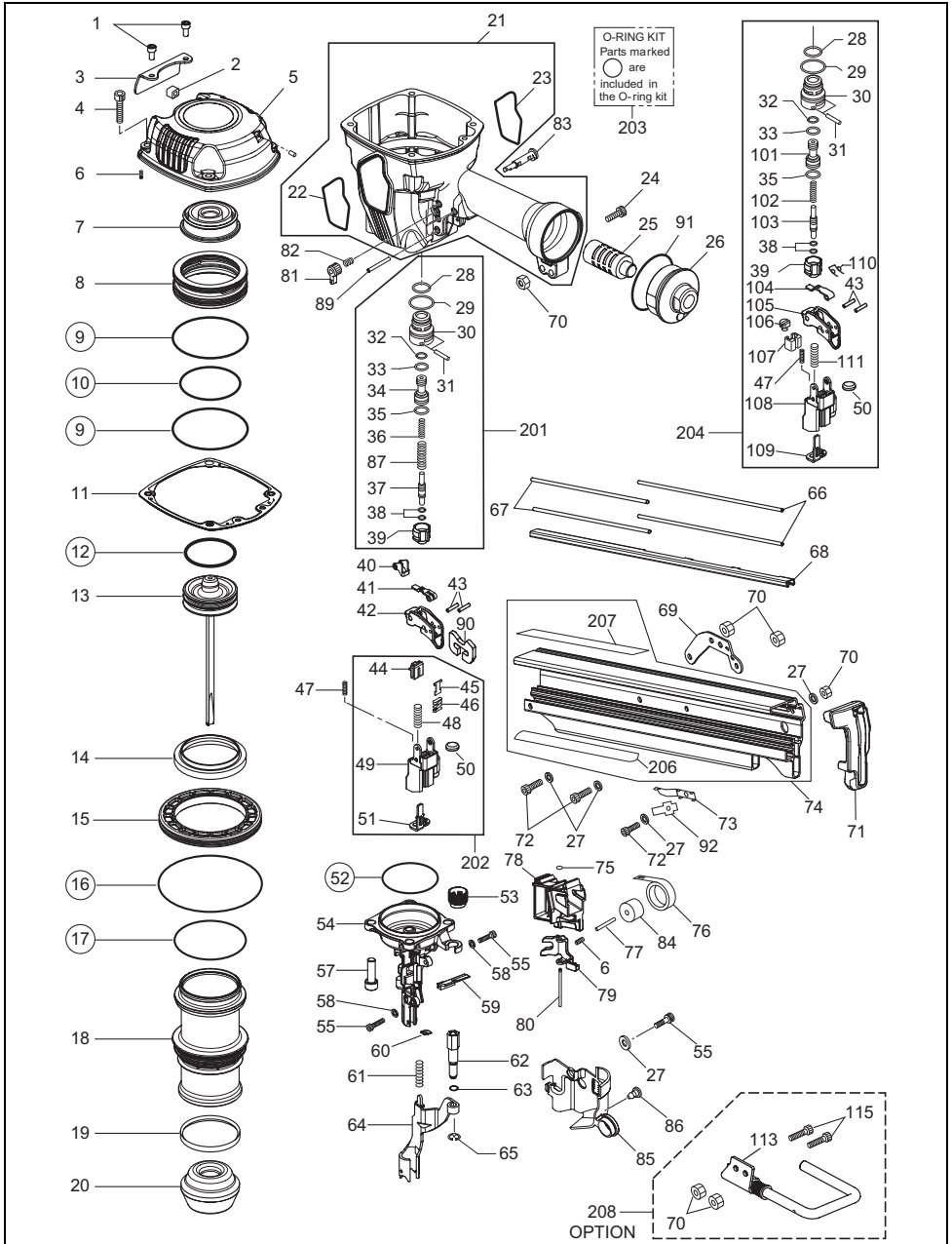

SN883RH2

ITEM NO.	PART NO.	MATERIAL	ENGLISH	FRANÇAIS	ESPAÑOL
1	KN12666	Steel	SCREW 5X12	VIS 5X12	TORNILLO 5X12
2	KN12678	Rubber	EXHAUST GUIDE	FILTRE ECHAPPEMENT	FILTRO DE ESCAPE
3	KN12194	Steel	EXHAUST COVER	CAPOT D'ASPIRATION	CAMPANA DE ASPIRACIÓN
4	KN12669	Steel	SCREW 6X28	VIS 6X28	TORNILLO 6X28
5	KN70168	Aluminum	CYLINDER CAP UNIT	COUVERCLE DE CYLINDRE COMPLET	CUBIERTA DE CILINDRO COMPL.
6	KN12653	Stainless steel	COMPRESSION SPRING 2653	RESSORT À PRESSION 2653	MUELLE DE COMPRESIÓN 2653
7	KN12627	Urethane	PISTON STOP	BUTÉE DE PISTON	TOPE EMBOLO
8	KN12656	Aluminum	HEAD VALVE PISTON	PISTON DE CLAPET DE TÊTE	EMBOLO VÁLVULA DEL CABEZAL
9	KN12650	Rubber	O-RING AS568-150	JOINT TORIQUE AS568-150	ANILLO TÓRICO AS568-150
10	KN12645	Rubber	O-RING AS568-142	JOINT TORIQUE AS568-142	ANILLO TÓRICO AS568-142
11	KN70142	Stainless steel, Rubber	CYLINDER CAP SEAL UNIT	UNITE DE RONDELLE DE COUVERCLE DE CYLINDRE	COMPL. DE CUBIERTA DE ARANDELA DE CILINDRO
12	KN12613	Rubber	O-RING 4.5X48.8	JOINT TORIQUE 4.5X48.8	ANILLO TÓRICO 4.5X48.8
13	KN70170	Magnesium, Steel	MAIN PISTON UNIT	PISTON DE TRAVAIL COMPLET	EMBOLO DE TRABAJO COMPL.
14	KN12628	Urethane	CYLINDER SEAL	RONDELLE DE CYLINDRE	ARANDELA DE CILINDRO
15	KN12190	Polyacetal	CYLINDER RING	JOINT DE CYLINDRE	ANILLO DE CILINDRO
16	KN12649	Rubber	O-RING 1AG100	JOINT TORIQUE 1AG100	ANILLO TÓRICO 1AG100
17	KN12648	Rubber	O-RING 1AG70	JOINT TORIQUE 1AG70	ANILLO TÓRICO 1AG70
18	KN12634	Aluminum	CYLINDER	CYLINDRE	CILINDRO
19	KN12614	Rubber	CHECK PAWL	CLIQUET D'ARRÊT	TRINQUETE
20	KN12193	Rubber	BUMPER	AMORTISSEUR	AMORTIGUADOR
21	KN81069	Aluminum	FRAME	BOÎTIER	CARCASA
22	KN12205	Aluminum	NAME LABEL A	JOINT DE NOM A	JUNTA DE NOMBRE A
23	KN12206	Aluminum	NAME LABEL B	JOINT DE NOM B	JUNTA DE NOMBRE B
24	KN12671	Steel	SCREW 5X28	VIS 5X28	TORNILLO 5X28
25	CN35685	Nylon	END CAP FILTER SA-10	FILTRE SA-10 DE CAPOT DE RECOUVREMENT	FILTRO DEL CAPPUCCIO DI CHIUSURA SA-10
26	KN12436	Aluminum	END CAP	CAPOT DE RECOUVREMENT	CAPERUZA DE CIERRE
27	EE31121	Steel	PLANE WASHER 1-5	RONDELLE LISSE 1-5	ARANDELA LISA 1-5
28	KN12643	Rubber	O-RING 1AP12	JOINT TORIQUE 1AP12	ANILLO TÓRICO 1AP12
29	KN12644	Rubber	O-RING 1AP20	JOINT TORIQUE 1AP20	ANILLO TÓRICO 1AP20
30	KN12636	Polyacetal	TRIGGER VALVE HOUSING	CARTER DE SOUPE DE DÉCLENCHEMENT	CUBIERTA DE VÁLVULA DEL DISPARADOR
31	KN12660	Stainless steel	PARALLEL PIN 2660	GOUPILLE PARALLELE 2660	PERNO PARALELO 2660
32	KN12642	Rubber	O-RING 1AP6	JOINT TORIQUE 1AP6	ANILLO TÓRICO 1AP6
33	KN12646	Rubber	O-RING 1BP7	JOINT TORIQUE 1BP7	ANILLO TÓRICO 1BP7
34	KN12664	Polyacetal	PILOT VALVE	VANNE-PILOTE	VÁLVULA DE CONTROL
35	KN12641	Rubber	O-RING 1AP9	JOINT TORIQUE 1AP9	ANILLO TÓRICO 1AP9
36	KN12654	Stainless steel	COMPRESSION SPRING 2654	RESSORT À PRESSION 2654	MUELLE DE COMPRESIÓN 2654
37	KN12658	Steel	TRIGGER VALVE STEM	TIGE DE SOUPE DE COMMANDE	VÁSTAGO VÁLVULA DE ACCIONAMIENTO
38	KN12647	Rubber	O-RING 1B 1.4X2.5	JOINT TORIQUE 1B 1.4X2.5	ANILLO TÓRICO 1B 1.4X2.5
39	KN12637	Polyacetal	TRIGGER VALVE CAP	CAPUCHON DE SOUPE DE COMMANDE	CAPERUZA VÁLVULA DE ACCIONAMIENTO
40	KN12635	Steel	CONTACT LEVER B	LEVIER DE CONTACT B	PALANCA DE CONTACTO B
41	KN12630	Steel	CONTACT LEVER A	LEVIER DE CONTACT A	PALANCA DE CONTACTO A
42	KN12401	Polyacetal	TRIGGER	LEVIER DE COMMANDE	PALANCA DE ACCIONAMIENTO
43	FF22402	Stainless steel	ROLL PIN 3X16	TOURILLON DE CYLINDRE 3X16	PERNO DE RODILLO 3X16
44	HS10145	Nylon	SWITCH LEVER A	LEVIER D'INTERRUPTEUR A	PALANCA DEL INTERRUPTOR A
45	KN12620	Steel	SWITCH LEVER B	LEVIER D'INTERRUPTEUR B	PALANCA DEL INTERRUPTOR B
46	CN34500	Stainless steel	SWITCH SPRING	RESSORT D'INTERRUPTEUR	MUELLE DEL INTERRUPTOR
47	KK23129	Stainless steel	COMPRESSION SPRING 3129	RESSORT À PRESSION 3129	MUELLE DE COMPRESIÓN 3129
48	KN23943	Stainless steel	COMPRESSION SPRING 3943	RESSORT À PRESSION 3943	MUELLE DE COMPRESIÓN 3943
49	KN12207	Nylon	ARM GUIDE	GUIDE DE BRAS DE CONTACT	GUÍA DEL BRAZO
50	KN12618	Rubber	EXHAUST SEAL	RONDELLE ECHAPPEMENT	ARANDELA DE ESCAPE
51	KN12212	Steel	CONTACT ARM A	BARRE DE CONTACT A	BRAZO DE CONTACTO A
52	KN12651	Rubber	O-RING AS568-144	JOINT TORIQUE AS568-144	ANILLO TÓRICO AS568-144
53	KN12200	Polyacetal	ADJUST DIAL	CADRAN DE RÉGLAGE	CUADRANTE DE AJUSTE
54	KN70172	Steel	NOSE UNIT	NEZ DU CLOUEUR COMPLET	PICO DEL CLAVADORCOMPL.
55	KN12668	Steel	SCREW 5X10	VIS 5X10	TORNILLO 5X10
56					
57	KN12670	Steel	SCREW 8X28	VIS 8X28	TORNILLO 8X28
58	KN12619	Steel	PLANE WASHER 5.1X12X1.2	RONDELLE LISSE 5.1X12X1.2	ARANDELA LISA 5.1X12X1.2
59	KN12617	Rubber	MAGAZINE GUIDE B	GUIDE DE MAGASIN B	GUÍA DE CARGADOR B

SN883RH2

ITEM NO.	PART NO.	MATERIAL	ENGLISH	FRAANÇAIS	ESPAÑOL
60	KN12616	Rubber	MAGAZINE GUIDE A	GUIDE DE MAGASIN A	GUÍA DE CARGADOR A
61	KK23694	Stainless steel	COMPRESSION SPRING 3964	RESSORT Á PRESSION 3964	MUELLE DE COMPRESIÓN 3964
62	KN12215	Steel	CONTACT BOLT	BOULON DE CONTACT	PERNO DE CONTACTO
63	KN12652	Rubber	O-RING 1A 1x6.2	JOINT TORIQUE 1A 1x6.2	ANILLO TÓRICO 1A 1x6.2
64	KN70171	Steel	CONTACT ARM B UNIT	BARRE DE CONTACT B	BRAZO DE CONTACTO B
65	KN12672	Stainless steel	E-RETAINING RING 5	BAGUE DE RETENUE E 5	ANILLO DE RETENCIÓN EN E 5
66	KN12624	Polycetal	NAIL GUIDE B	GUIDE DE CLOUS B	GUÍA DE CLAVOS B
67	KN12663	Stainless steel	NAIL GUIDE A	GUIDE DE CLOUS A	GUÍA DE CLAVOS A
68	KN12629	Stainless steel	NAIL COVER	COUVERCLE DE CLOUS	CUBIERTA DE CLAVOS
69	KN12203	Steel	TAIL HANGER	SUPPORT DE QUEUE	SOPORTE DE COLA
70	CC49411	Steel, Nylon	NUT M5	ECROU M5	TUERCA M5
71	KN12623	Nylon	TAIL COVER	COUVERCLE DE QUEUE	CUBIERTA DE COLA
72	KN12667	Steel	SCREW 5X14	VIS 5X14	TORNILLO 5X14
73	KN12419	Stainless steel	NAIL STOPPER	PIECE ARRET DE CLOUS	TOPE DE CLAVOS
74	KN81068	Aluminum	MAGAZINE	MAGASIN	CARGADOR
75	GN12070	Steel	RUBBER WASHER 1.8x6x2	DISQUE DE CAOUTCHOUC 1.8x6x2	ARANDELA DE CAUCHO 1.8x6x2
76	KN12640	Stainless steel	SPIRAL SPRING 2640	RESSORT SPIRAL 2640	MUELLE ESPIRAL 2640
77	KN12661	Stainless steel	PARALLEL PIN 2661	GOUPILLE PARALLELE 2661	PERNO PARALELO 2661
78	KN12625	Nylon	PUSHER HOLDER	SUPPORT DE POUSSOIR	SOPORTE DE EMPUJADOR
79	KN12633	Steel	PUSHER	POUSSOIR	EMPUJADOR
80	KN12662	Steel	PARALLEL PIN 2662	GOUPILLE PARALLELE 2662	PERNO PARALELO 2662
81	KN12622	Nylon	TRIGGER LOCK LEVER	LEVIER DE BLOCAGE DE LA COMMANDE	PALANCA, BLOQUEO DE ACCIONAMIENTO
82	KK23507	Stainless steel	COMPRESSION SPRING 3507	RESSORT Á PRESSION 3507	MUELLE DE COMPRESIÓN 3507
83	KN12621	Nylon	TRIGGER LOCK DIAL	DISQUE DE BLOCAGE DE LA COMMANDE	DISCO, BLOQUEO DE ACCIONAMIENTO
84	KN12626	Polycetal	SPRING COLLAR	COLLIER DE RESSORT	COLLAR DE MUELLE
85	KN12204	Nylon	ARM COVER	COUVERCLE DE BRAS	CUBIERTA DEL BRAZO
86	CN31083	Rubber	DUST COVER HOOK	CROCHET DE COUVERCLE ANTI-POUSSIÈRE	GANCHO DE LA TAPA GUARDAPOLVO
87	KN12655	Stainless steel	COMPRESSION SPRING 2655	RESSORT Á PRESSION 2655	MUELLE DE COMPRESIÓN 2655
88					
89	FF21235	Steel	ROLL PIN 3X30	TOURILLON DE CYLINDRE 3X30	PERNO DE RODILLO 3X30
90	KN12615	Steel	SWITCHING LEVER	LEVIER DE COMMUTATION	PALANCA DE CONMUTACIÓN
91	HH12111	Rubber	O-RING 1AG45	JOINT TORIQUE 1AG45	ANILLO TÓRICO 1AG45
92	KN12420	Stainless steel	NAIL STOPPER B	PIECE ARRET DE CLOUS B	TOPE DE CLAVOS B
101	CN32246	Polycetal	PILOT VALVE	VANNE-PILOTE	VÁLVULA DE CONTROL
102	KK24123	Stainless steel	COMPRESSION SPRING 4123	RESSORT Á PRESSION 4123	MUELLE DE COMPRESIÓN 4123
103	CN35128	Steel	TRIGGER VALVE STEM	TIGE DE SOUPAPE DE COMMANDE	VÁSTAGO VÁLVULA DE ACCIONAMIENTO
104	HN10100	Steel	CONTACT LEVER	LEVIER DE CONTACT	PALANCA DE CONTACTO
105	HS10118	Polycetal	TRIGGER	LEVIER DE COMMANDE	PALANCA DE ACCIONAMIENTO
106	HN10786	Stainless steel	ARM GUIDE PLATE	PLAQUE DE GUIDE DE BRAS	PLACA DE GUÍA DEL BRAZO
107	KN12277	Steel	CONTACT ARM A GUIDE	GUIDE DE BRAS DE CONTACT A	GUÍA DEL BRAZO DE CONTACTO A
108	KN12278	Nylon	ARM GUIDE	GUIDE DE BRAS DE CONTACT	GUÍA DEL BRAZO
109	KN12276	Steel	CONTACT ARM A	BARRE DE CONTACT A	BRAZO DE CONTACTO A
110	KK33300	Stainless steel	TORSION SPRING 3300	RESSORT DE TORSION 3300	MUELLE DE TORSIÓN 3300
111	KK23973	Stainless steel	COMPRESSION SPRING 3973	RESSORT Á PRESSION 3973	MUELLE DE COMPRESIÓN 3973
113	KN12405	Steel, Stainless steel	RAFTER HOOK	CROCHET DE COMBLE	GANCHO DE CIMA
115	BB40027	Steel	SCREW 5X30	VIS 5X30	TORNILLO 5X30
201	KN81070		TRIGGER VALVE KIT	KIT DE SOUPAPE DE COMMANDE	KIT VÁLVULA DE ACCIONAMIENTO
202	KN81071		ARM GUIDE KIT	KIT DE GUIDE DE BRAS	KIT DE LA GUÍA DEL BRAZO
203	KN81074		O-RING KIT	KIT DE JOINT TORIQUE	KIT DE ANILLO TÓRICO
204	KN81027		SEQUENTIAL TRIP KIT	KIT DE DÉCLENCHEMENT SÉQUENTIEL	KIT DE DISPARO SECUENCIAL
206	4009561	PET	NAME LABEL	JOINT DE NOM	JUNTA DE NOMBRE
207	4009560	PET	CAUTION LABEL	ÉTIQUETTE DE PRÉCAUTION	ETIQUETA DE PRECAUCIÓN
208	KN81035		RAFTER HOOK KIT	KIT DE CROCHET DE COMBLE	EQUIPO DE GANCHO DE CIMA