

Tanaka Illustrated Parts Manual

Model Number:

TPB-350GX

35cc PowerBoard

P/N 31640

Rev 000

Date 4-24-06



Supplier To The Outdoor Power Equipment Industry

ISM, Inc. • 1028 4th Street SW • Auburn, WA 98001 • Phone: (253) 333-1200 • Fax: (253) 333-1212

www.tanaka-usa.com

custsvc@tanaka-ism.com

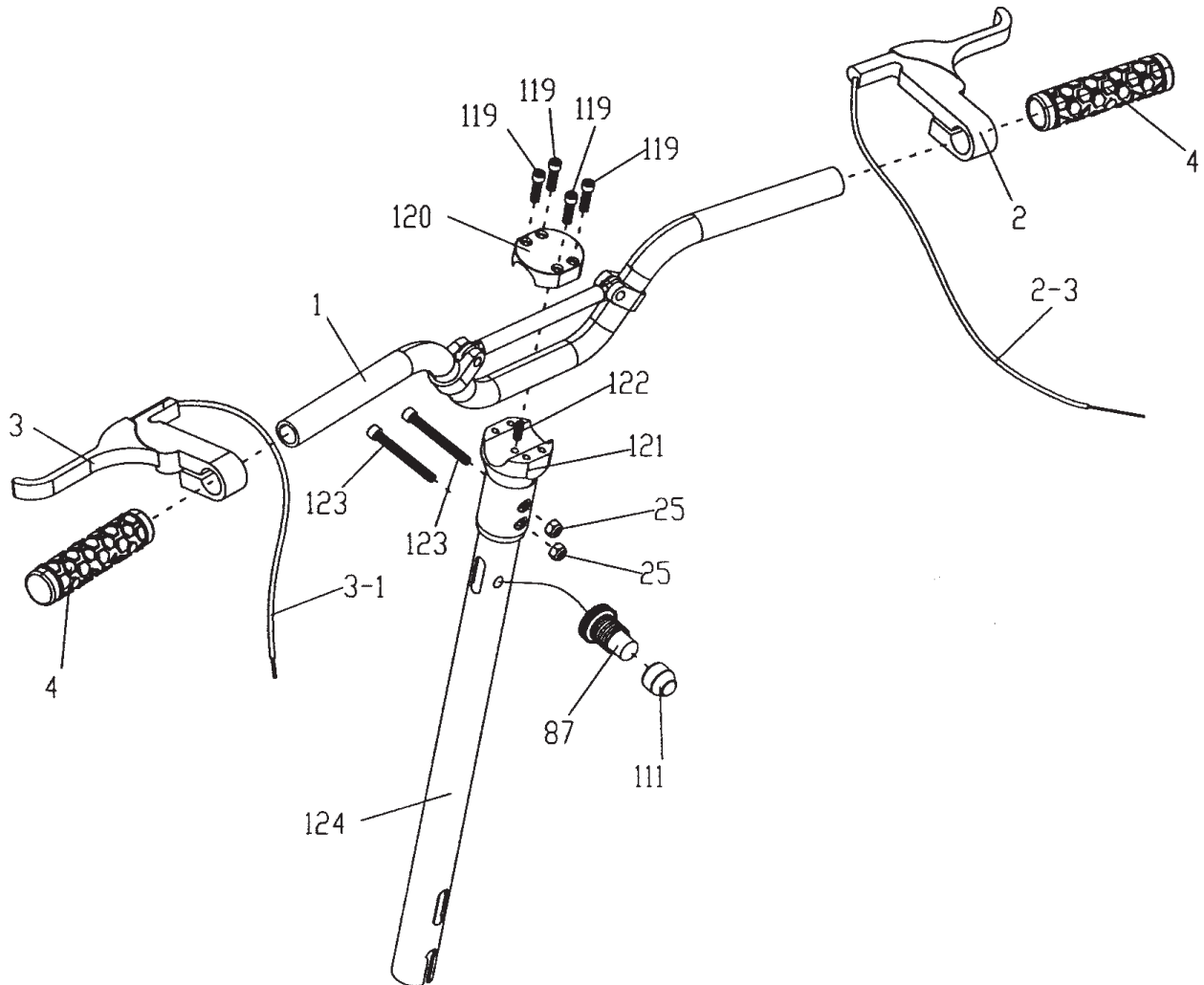

ITEM	PART NUMBER	DESCRIPTION	QTY	COMMENTS
1-1	31552	HANDLEBAR,RACING	1	
1-2	30799	THROTTLE LEVER ASSY	1	
1-2-3	31228	CABLE,THROTTLE	1	
1-3	30801	LEVER,BRAKE	1	Includes hardware - not sold separately
1-3-1	31229	CABLE,BRAKE	1	
1-4	30798	GRIP,HANDLE	2	
1-25	31658	NUT	2	
1-87	30806	SWITCH,BUTTON	1	
1-111	30938	COVER,STOP BUTTON	1	
1-119	31563	BOLT,M6xP1.0x20	4	
1-120	31564	STEERING STEM CAP	1	
1-121	31565	STEERING STEM	1	
1-122	31566	BOLT,M6xP1.0x15	1	
1-123	31567	BOLT,M6xP1.0x42	2	
1-124	31568	STEERING PIPE	1	

HEAD PIPE & FOLDING HANDLE • FIGURE 2

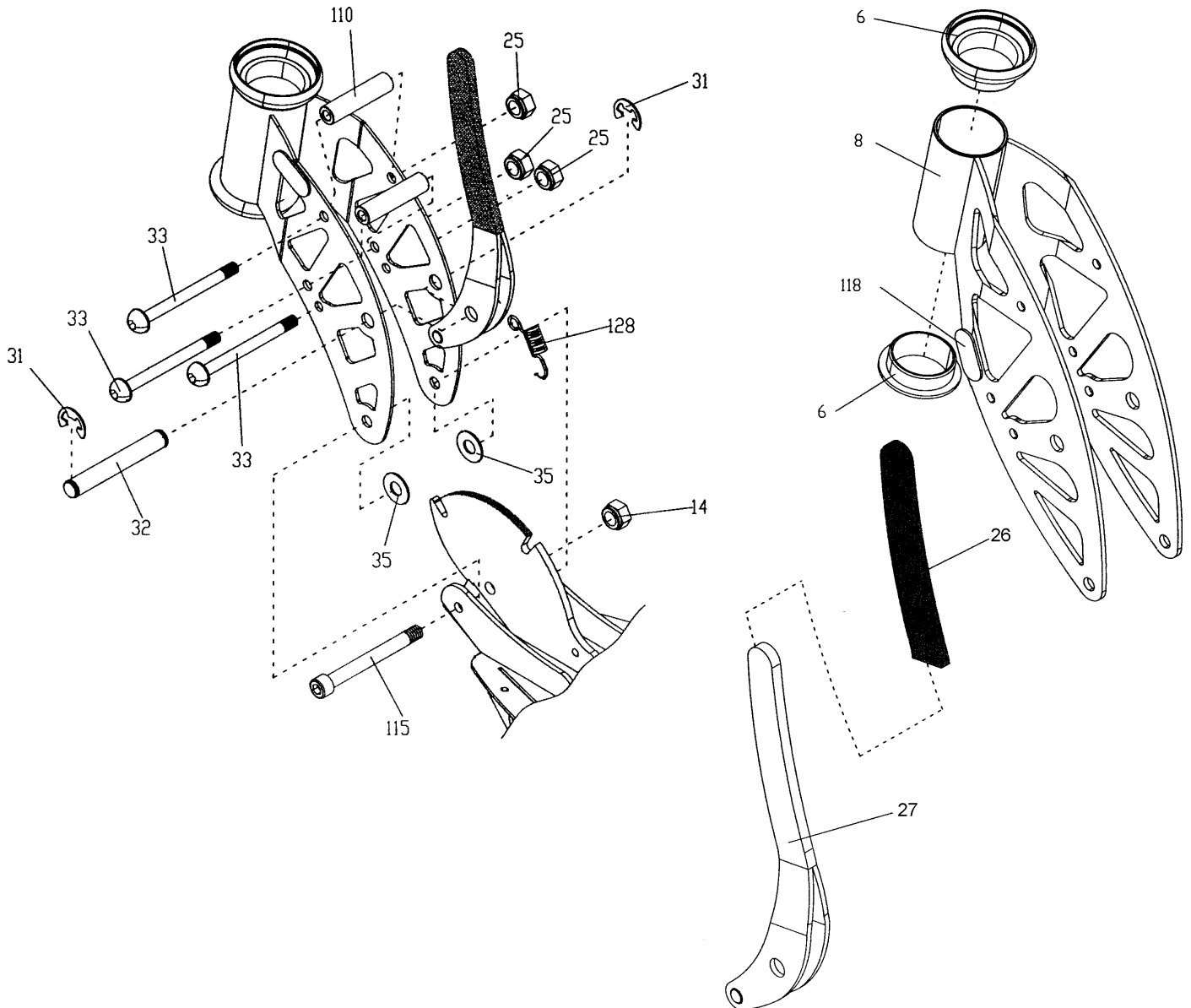

ITEM	PART NUMBER	DESCRIPTION	QTY	COMMENTS
2-6	30845	SPACER,FRONT HANDLE	1	
2-8	31659	TUBE,HEAD (GREY)	1	
2-14	30821	NUT,M8xP1.25	1	
2-25	30936	NUT,M6xP1.0	3	
2-26	30870	GRIP,FOLDING HANDLE	1	
2-27	31661	HANDLE,FOLDING,(GREY)	1	
2-31	30862	RING,E	2	
2-32	30863	PIN,HEAD TUBE	1	
2-33	30868	BOLT	3	
2-35	30864	WASHER	2	
2-110	31078	SPACER,T-937	2	
2-115	31663	BOLT	1	
2-118	31664	PAD,CUSHION	2	
2-128	31662	SPRING,FOLDING HANDLE	1	

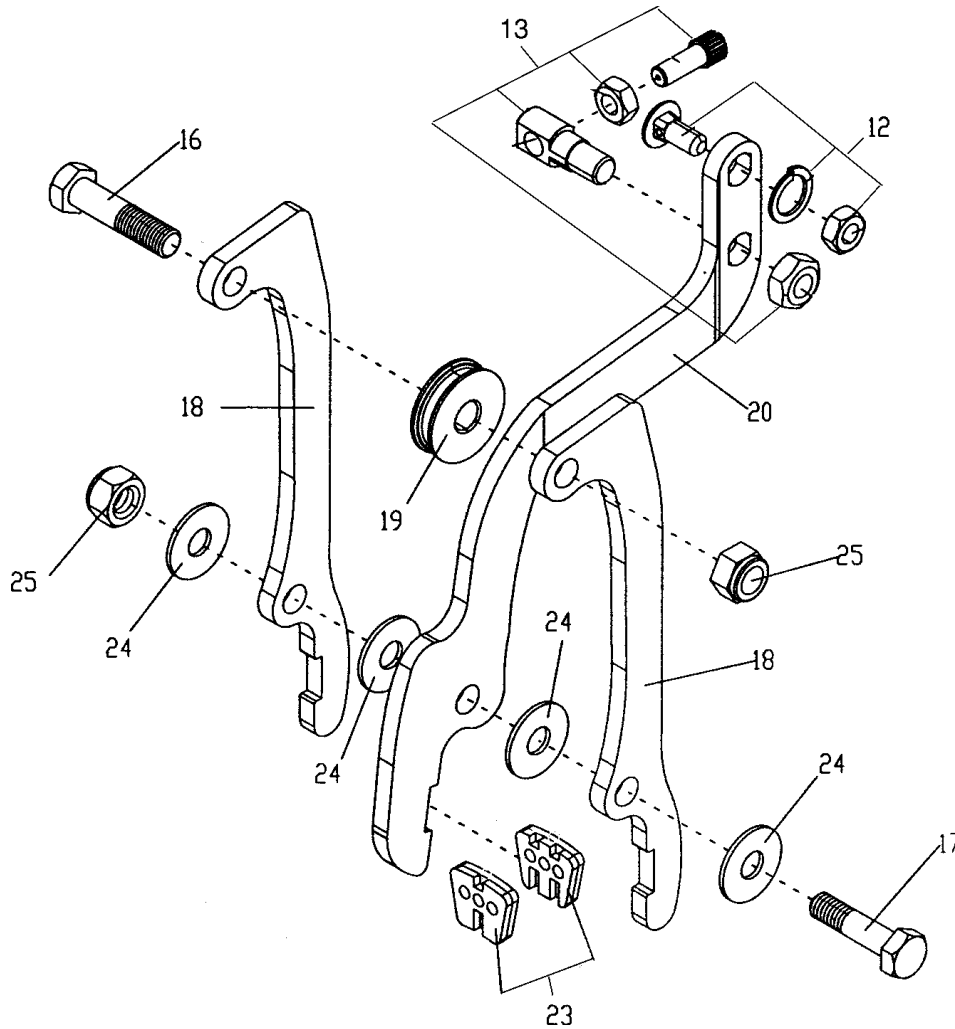

ITEM	PART NUMBER	DESCRIPTION	QTY	COMMENTS
3-12	30851	KIT,BRAKE ARM HDWE	1	
3-13	30852	KIT,BRAKE CABLE RECEIVER	1	
3-16	30855	BOLT	1	
3-17	30859	BOLT	1	
3-18	30854	ARM,BRAKE,(SMALL)	2	
3-19	30856	WHEEL,BRAKE	1	
3-20	30853	ARM,BRAKE,(LARGE)	1	
3-23	30930	BRAKE PAD SET	1	
3-24	30860	WASHER	4	
3-25	30936	NUT,M6xP1.0	2	

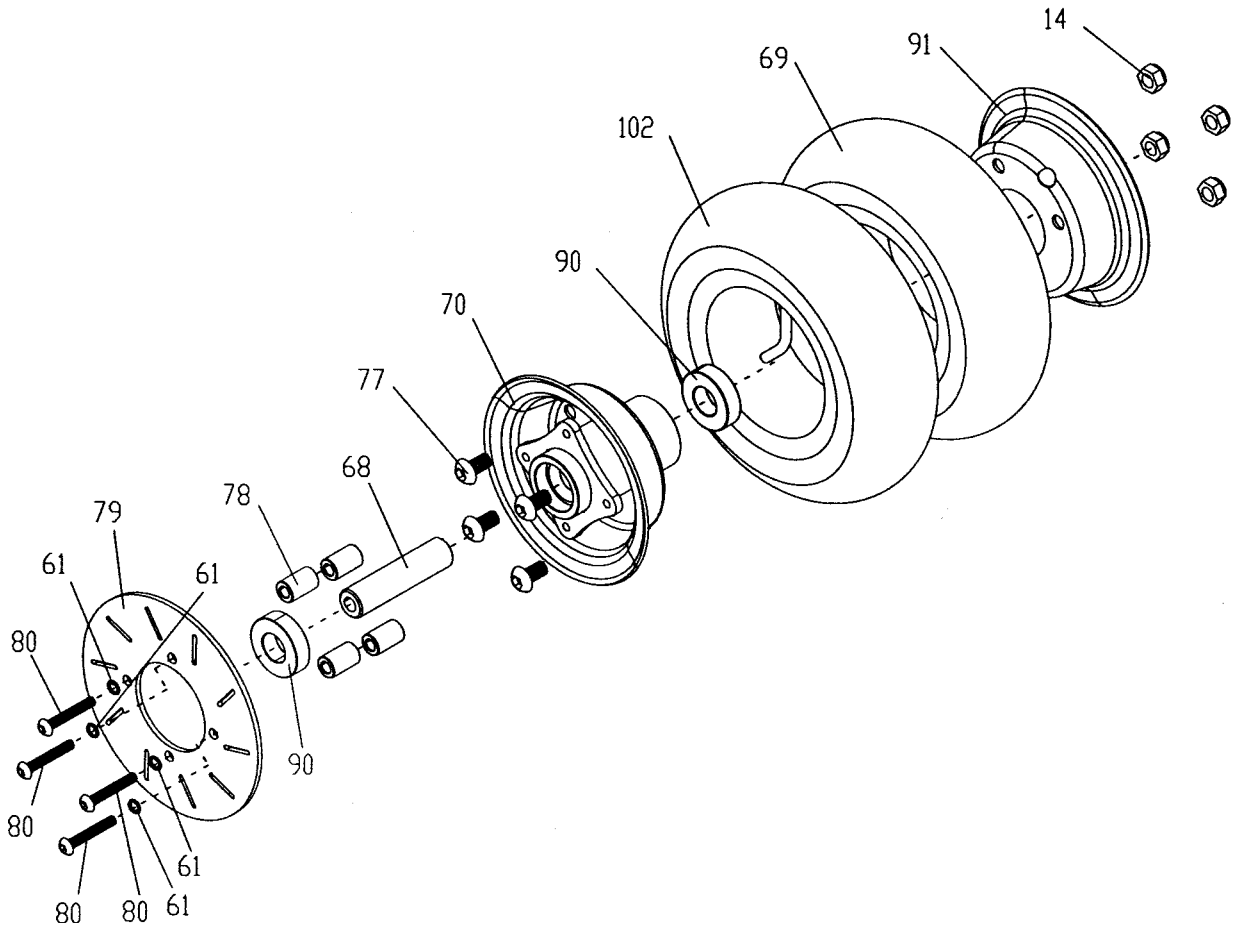

ITEM	PART NUMBER	DESCRIPTION	QTY	COMMENTS
4-14	30821	NUT, M8xP1.25	4	
4-61	30830	WASHER, SPRING M6	4	
4-68	30827	SPACER, T-789	1	
4-69	30823	TIRE, 10"	1	
4-70	30825	HUB, (WELD)	1	
4-77	30826	BOLT, M8xP1.25x15	4	
4-78	30828	SPACER, BRAKE, T-790	4	
4-79	30829	DISC, BRAKE	1	
4-80	30831	BOLT, M6xP1.0x32	4	
4-90	30883	BEARING, 6200-2RS	2	
4-91	30822	HUB, (5 HOLES)	1	
4-102	30911	TUBE, TIRE	1	

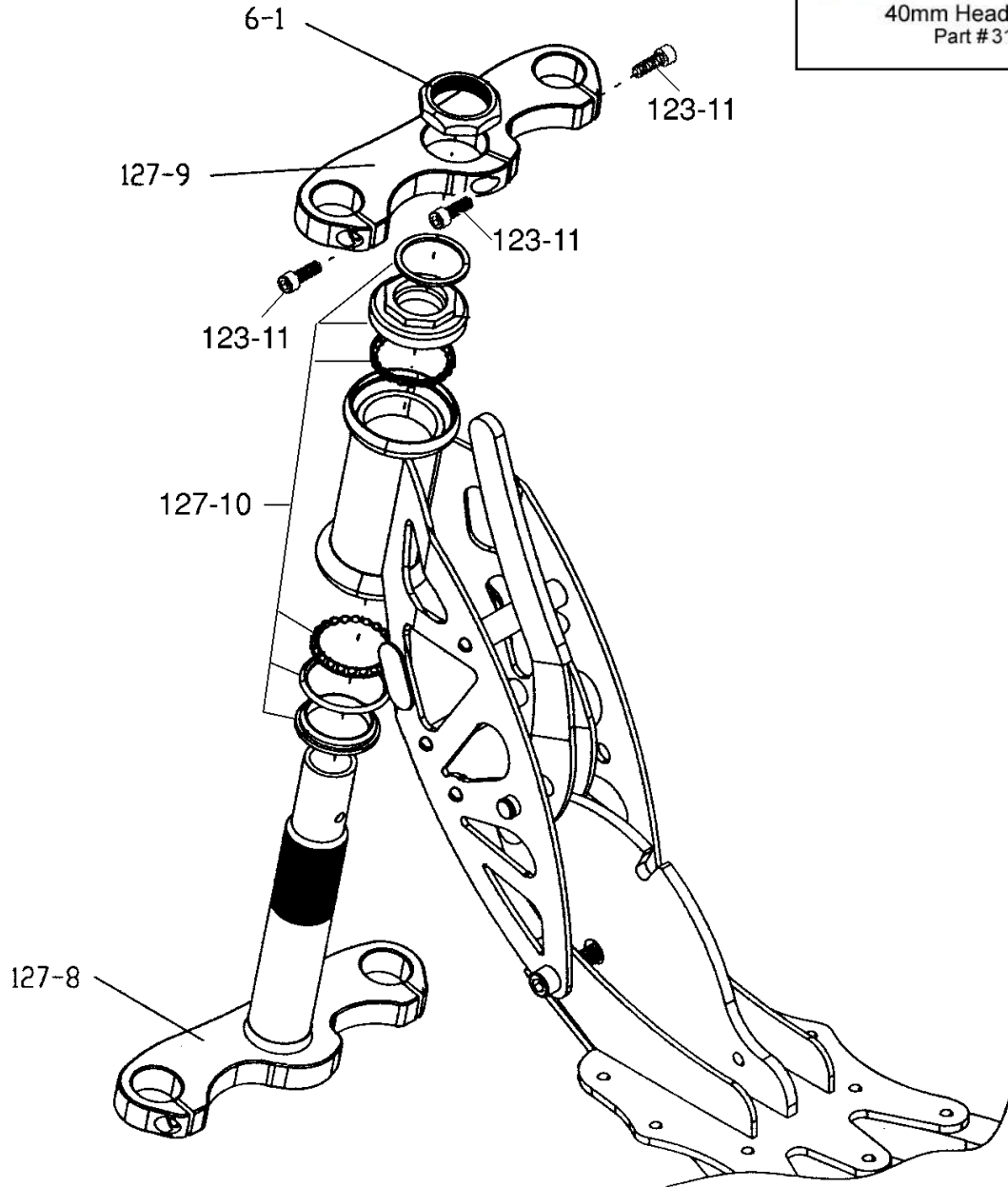

ITEM	PART NUMBER	DESCRIPTION	QTY	COMMENTS
5-6-1	31554	OCTAGON 1.25"	1	
5-123-11	31730	SCREW,CHROME	5	
5-127-8	31580	TRIPLE CLAMP,BOTTOM	1	
5-127-9	31581	TRIPLE CLAMP, TOP	1	
5-127-10	31671	HEAD BEARING KIT	1	

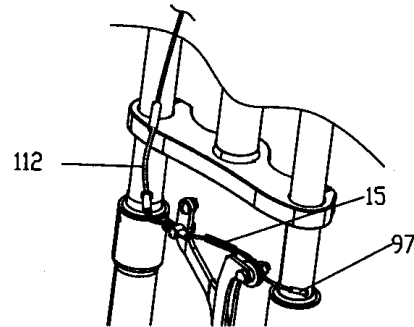
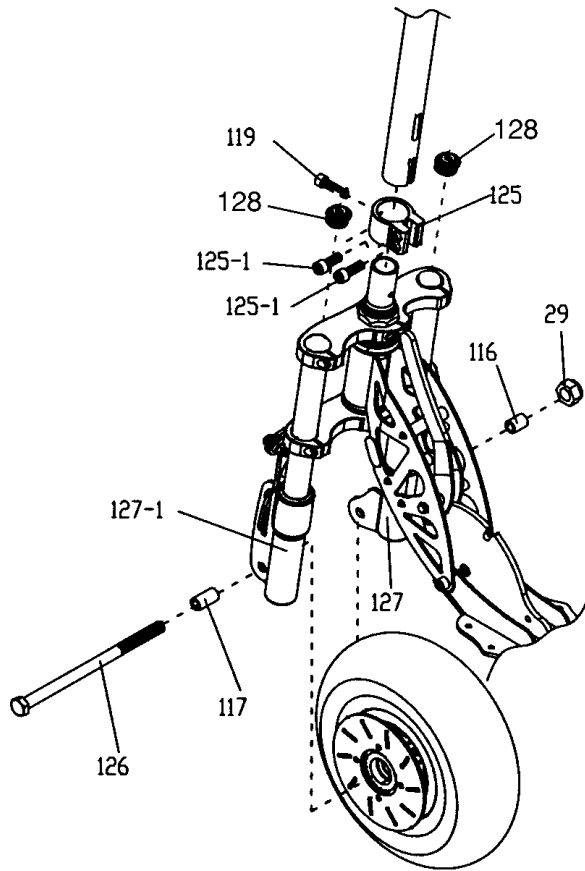

ITEM	PART NUMBER	DESCRIPTION	QTY	COMMENTS
6-15	31080	SPRING,S-043	1	
6-29	30880	NUT,M10xP1.5	1	
6-97	31082	CAP,CABLE END	1	
6-112	31665	BRAKE WIRE CONDUIT	1	
6-116	31667	SPACER	1	
6-117	31666	SPACER	1	
6-119	31668	SCREW	1	
6-125	31569	HANDLE STEM CONNECTOR	1	
6-125-1	31669	SCREW	2	
6-126	31571	BOLT,M10xP1.5x160	1	
6-127	31572	SHOCK,(R)	1	Caution - Do not disassemble shocks!
6-127-1	31573	SHOCK,(L)	1	Extreme pressure and not serviceable!
6-128	31706	NUT, TOP, TRIPLE CLAMP	2	

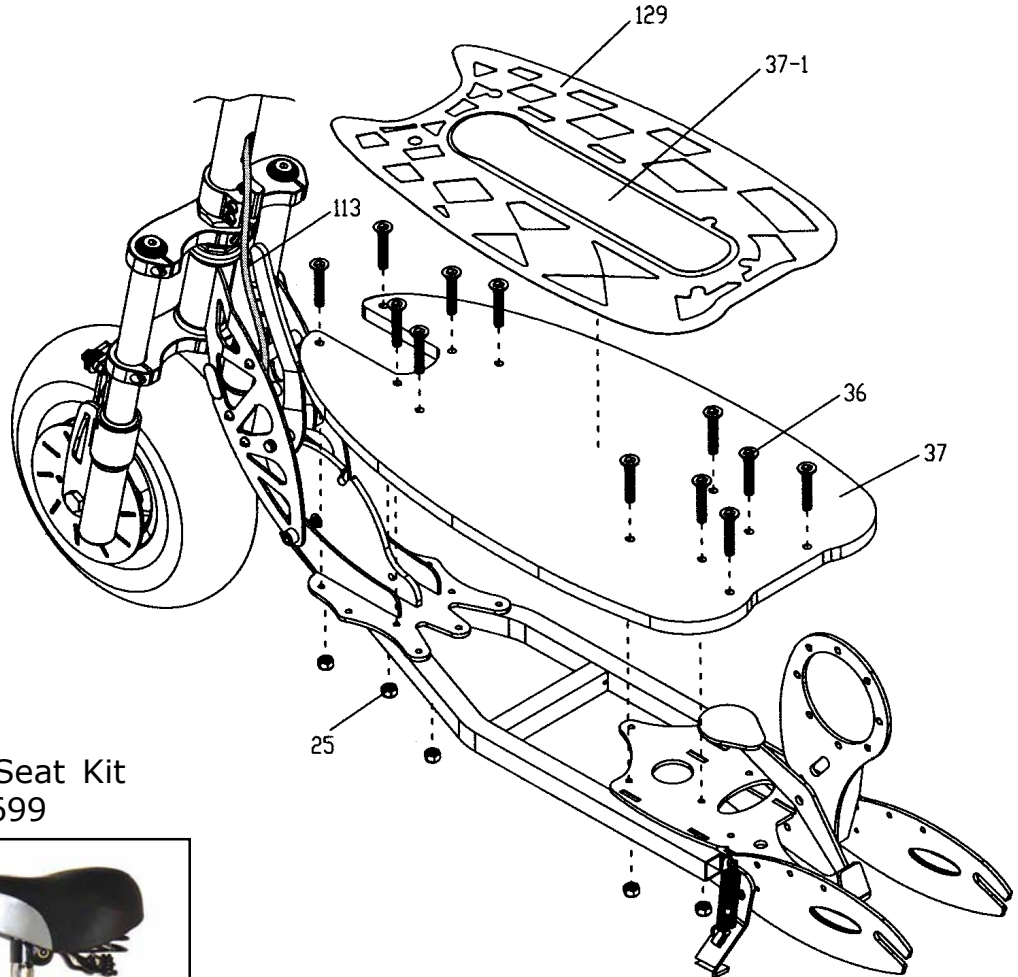

Optional Seat Kit
#31699



ITEM	PART NUMBER	DESCRIPTION	QTY	COMMENTS
7-25	30936	NUT, M6xP1.0	5	
7-36	30912	SCREW, BOARD	12	
7-37	31083	DECK, WOOD, PAVERUNNER 350	1	
7-37-1	31672	DECAL, DECK, PAVERUNNER	1	
7-129	31673	GRIP TAPE, PAVERUNNER	1	

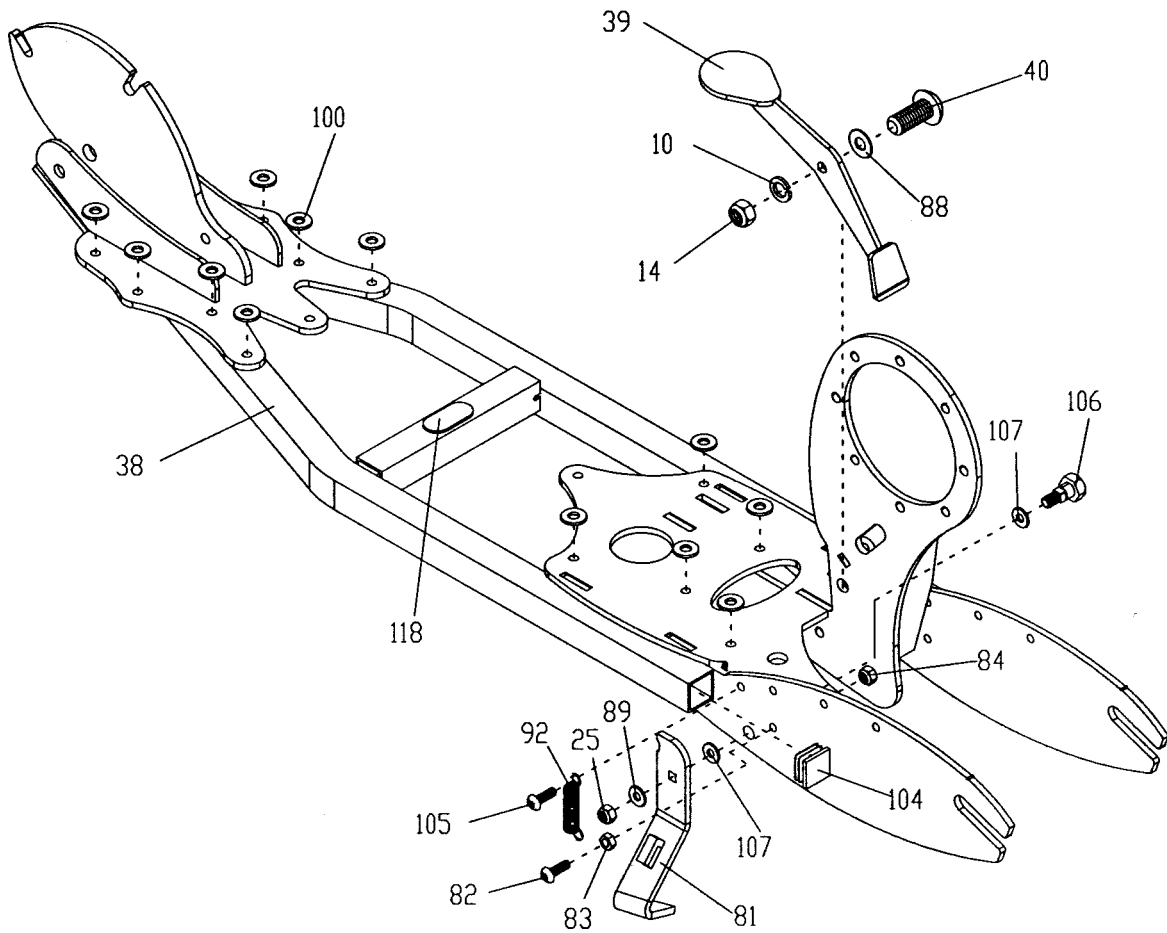

ITEM	PART NUMBER	DESCRIPTION	QTY	COMMENTS
8-10	30819	WASHER,SPRING	1	
8-14	30821	NUT,M8xP1.25	1	
8-25	30936	NUT,M6xP1.0	1	
8-38	31674	FRAME,PAVERUNNER,GREY	1	
8-39	30817	PEDAL,REAR BRAKE	1	
8-40	30816	BOLT,K-236	1	
8-81	30812	STAND,KICK	1	
8-82	30810	BOLT,M5xP0.8x15	1	
8-83	30936	NUT,M6xP1.0	1	
8-84	30809	NUT,M5xP0.8	1	
8-88	30818	WASHER	1	
8-89	30813	WASHER	1	
8-92	30811	SPRING,KICK STAND	1	
8-100	30815	WASHER,RUBBER	14	
8-104	31087	CAP,FLAT	1	
8-105	30810	BOLT,M5xP0.8x15	1	
8-106	31675	BOLT	1	
8-107	31676	WASHER	2	
8-118	31664	PAD,CUSHION	1	

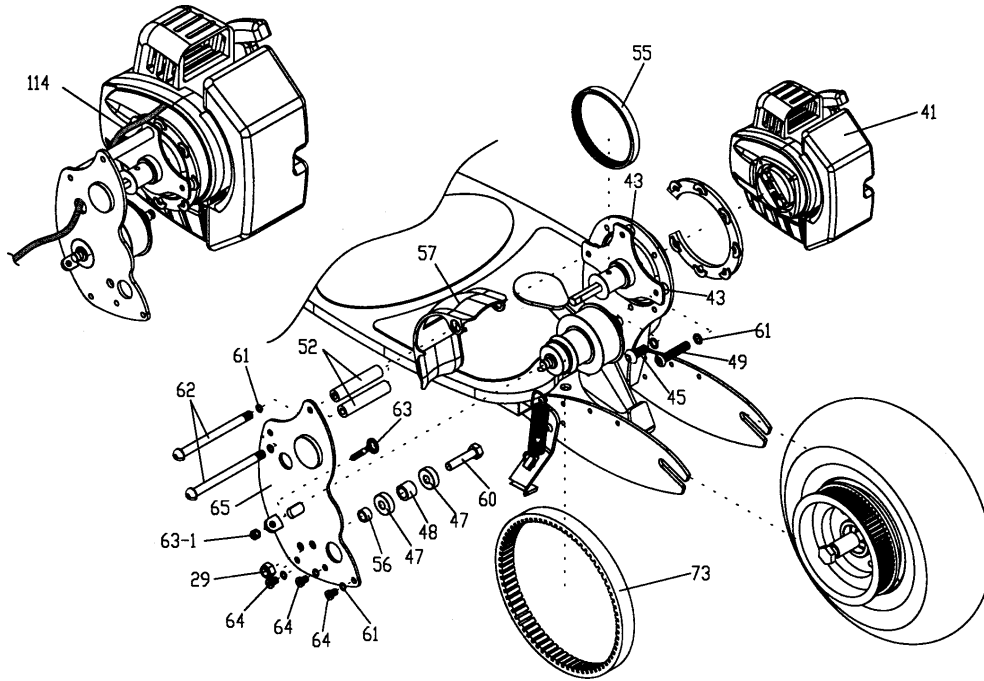

Belt Adjustment / Replacement Procedures

ITEM	PART NUMBER	DESCRIPTION	QTY	COMMENTS
9-29	30880	NUT,M10xP1.5	1	
9-41	TC-355	Complete Replacement Engine,35cc	1	
9-41	PF-4000	Complete Replacement Engine,40cc	1	
9-41	TC-4700	Complete Replacement Engine,47cc	1	
9-43	30917	SPACER,SHORT	3	
9-45	31150	BOLT,M6xP1.0x25,RD HD	1	
9-47	30834	BEARING,6000-2RS	2	
9-48	31091	SPACER,T-804	1	
9-49	31383	BOLT,M6XP1.0X35,RD HD	1	
9-52	31092	SPACER,T-693	2	
9-55	30923	BELT,CLUTCH,(SMALL)	1	
9-56	31093	SPACER,T-797	1	
9-57	30915	FENDER	1	
9-60	31094	BOLT,M10xP1.5x45	1	
9-61	30830	WASHER,SPRING M6	7	
9-62	31095	BOLT,K-222	2	
9-63	31096	SCREW,M6xP1.0x40	2	
9-63-1	31677	NUT	1	
9-64	31097	BOLT,M6xP1.0x10	3	
9-65	31678	PLATE,SUPPORT,GREY	1	
9-73	30921	BELT,DRIVE,(LARGE)	1	
9-93	30959	MOUNTING RING	1	



Custom Gold Valve Caps
Part # 31257



Custom Chrome Valve Caps
Part # 31256

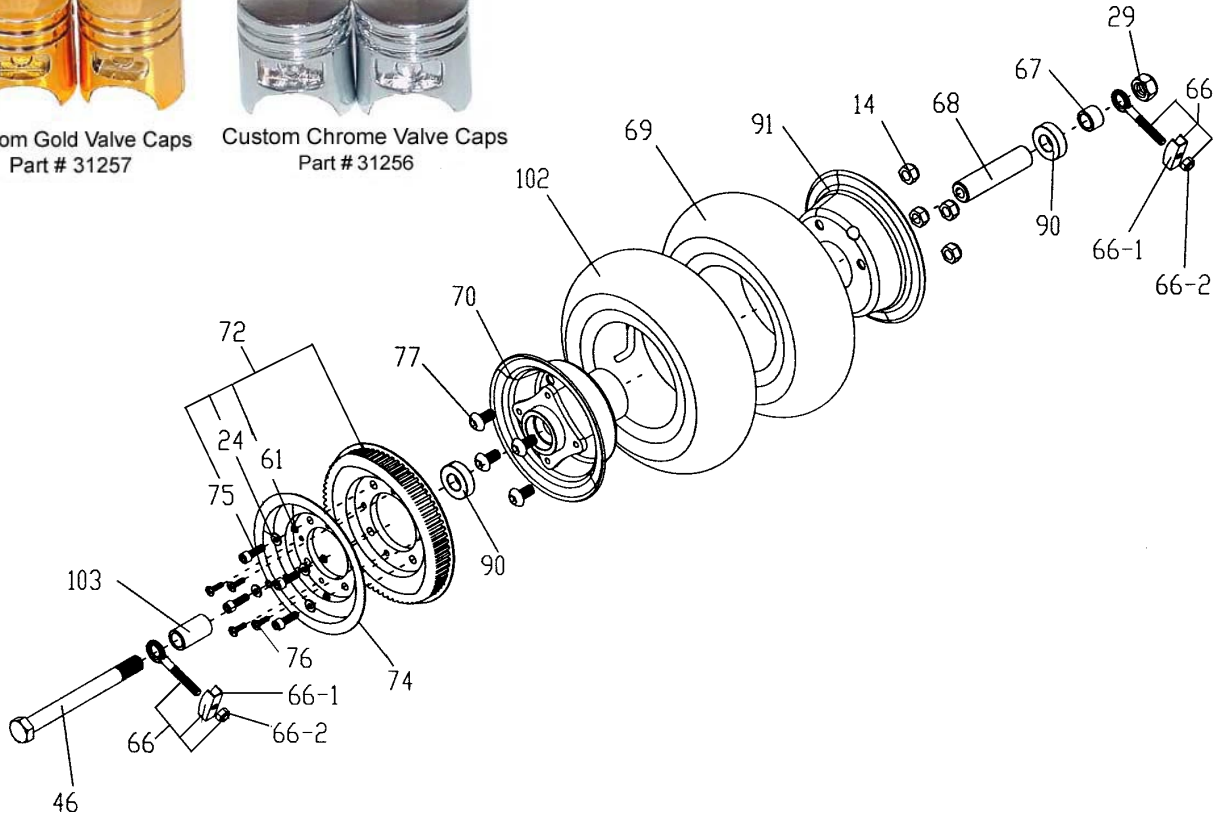

ITEM	PART NUMBER	DESCRIPTION	QTY	COMMENTS
10-14	30821	NUT,M8xP1.25	4	
10-24	31100	WASHER	4	
10-29	30880	NUT,M10xP1.5	1	
10-46	30891	BOLT,AXLE 10x145	1	
10-61	30830	WASHER,SPRING M6	4	
10-66	30881	SCREW,REAR AXLE TENSION	2	
10-66-1	31679	BASE,ADJUSTER	1	
10-66-2	31680	NUT,ADJUSTER	1	
10-67	30886	SPACER,REAR WHEEL,(L)	1	
10-68	30884	SPACER	1	
10-69	30823	TIRE,10"	1	
10-70	30825	HUB,(WELD)	1	
10-72	30887	PULLEY,REAR DRIVE	1	
10-74	30888	GUARD,BELT	1	
10-75	30889	BOLT,6x20	4	
10-76	30890	SCREW	4	
10-77	30826	BOLT,M8xP1.25x15	4	
10-90	30883	BEARING,6200-2RS	2	
10-91	30822	HUB,(5 HOLES)	1	
10-102	30911	TUBE,TIRE	1	
10-103	30882	SPACER,REAR WHEEL (R)	1	

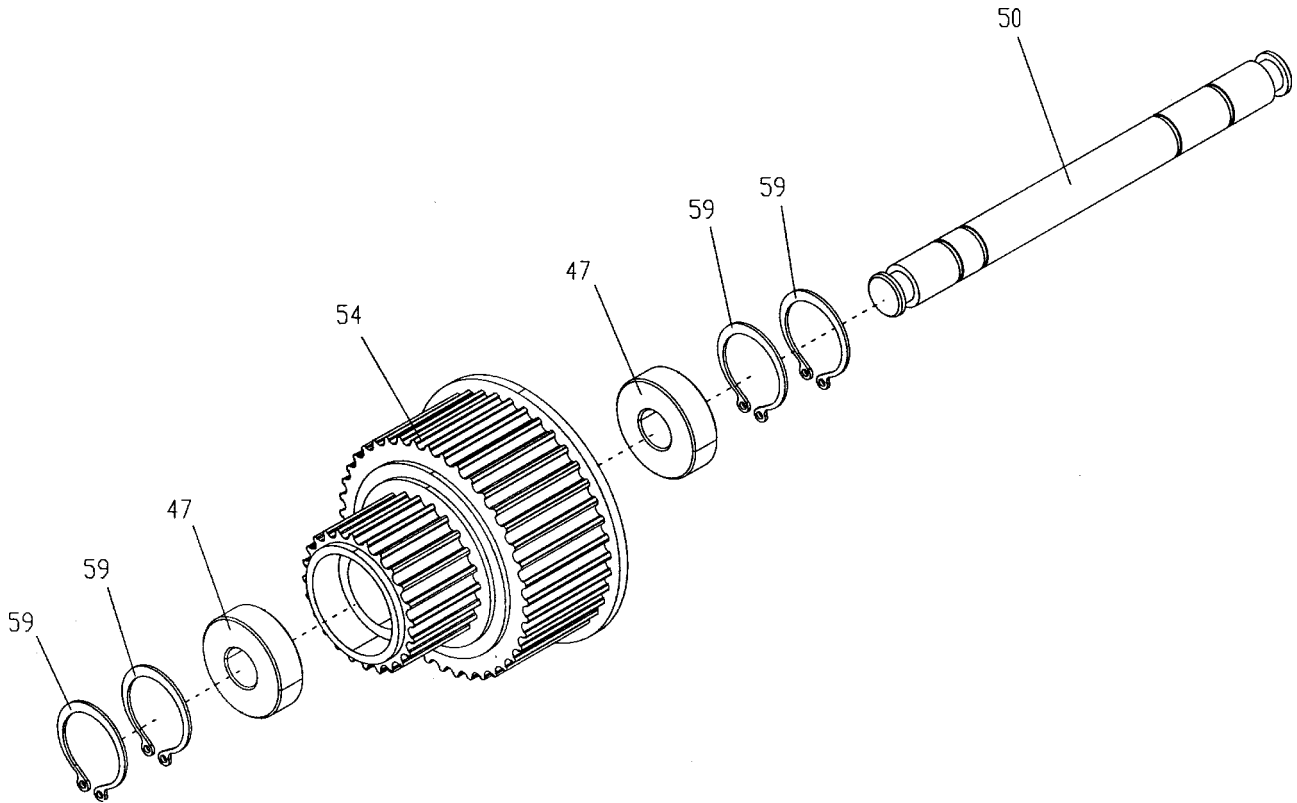

ITEM	PART NUMBER	DESCRIPTION	QTY	COMMENTS
11-47	30834	BEARING,6000-2RS	2	
11-50	30832	SHAFT,T-796	1	
11-54	30835	GEAR,LARGE	1	
11-59	30833	RING,C	4	

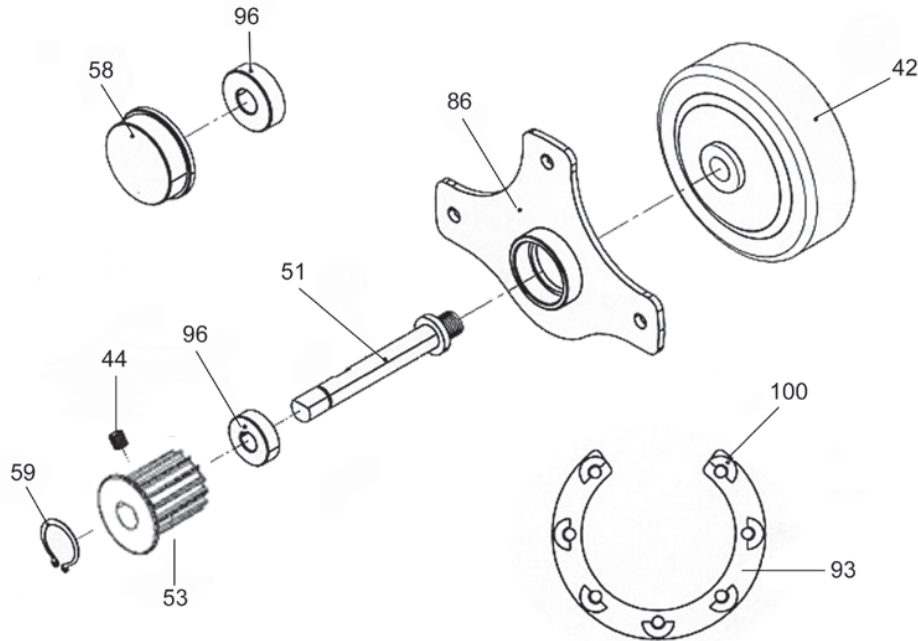

Power & Speed Sprockets



- 32099 POWER SPROCKET,13TH
- 32100 POWER SPROCKET,14TH
- 32101 SPEED SPROCKET,16TH
- 32102 SPEED SPROCKET,17TH
- 32103 SPEED SPROCKET,18TH

ITEM	PART NUMBER	DESCRIPTION	QTY	COMMENTS
12-42	30836	DRUM,CLUTCH	1	
12-44	30839	BOLT,M5xP0.8x5	1	
12-51	30838	SHAFT,CLUTCH	1	
12-51	70100	SHAFT,CLUTCH, LONG,4in	1	
12-53	30840	SPROCKET,(SMALL)	1	
12-58	30842	HOLDER,BEARING	1	
12-59	30841	RING,C	1	
12-86	30837	PLATE,MOUNTING	1	
12-93	30959	MOUNTING RING	1	
12-96	30834	BEARING,6000-2RS	2	
12-100	30844	WASHER,RUBBER	4	

CYLINDER, PISTON, CRANKSHAFT • FIGURE 1

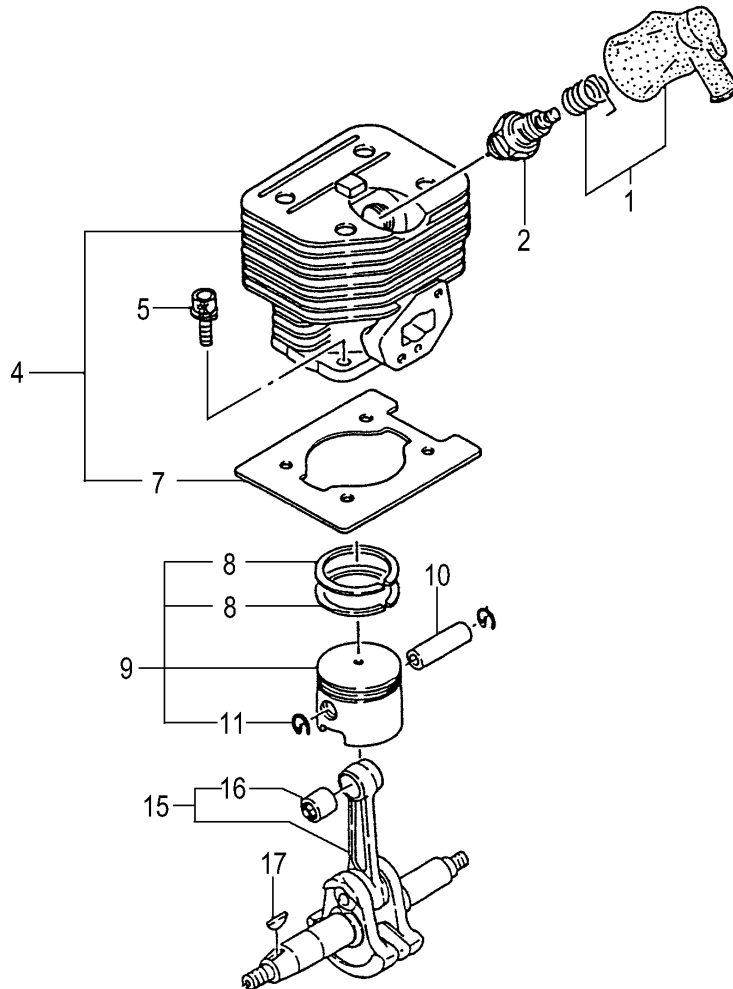

ITEM	PART NUMBER	DESCRIPTION	QTY	COMMENTS
1-1	1570097A900	CAP, SPARK PLUG, ASS'Y	1	
1-2	01802233200	PLUG, SPARK	1	
1-4	0010143C90	CYLINDER SET	1	Includes gasket
1-5	99461050184	BOLT, HEX, 5X18, S	4	
1-7	01701380200	GASKET, CYLINDER	1	
1-8	04104000200	RING, PISTON	2	
1-9	0300143C90	PISTON SET	1	Includes rings & circlips
1-10	03701400200	PIN, PISTON	1	
1-11	03900000201	CIRCLIP, PISTON PIN	2	
1-15	0460135082	CRANKSHAFT	1	
1-16	99962091325	BEARING, NEEDLE, F-910	1	
1-17	06810100200	KEY, WOODRUFF, 3X13X4.5	1	

CRANKCASE, FLYWHEEL, STARTER PULLEY • FIGURE 2

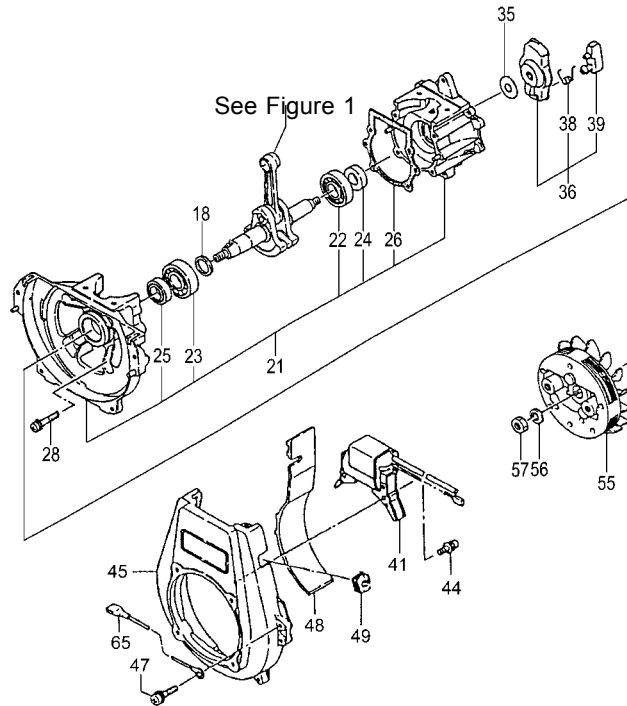

ITEM	PART NUMBER	DESCRIPTION	QTY	COMMENTS
2-18	07102007200	SHIM, 15.2X20X.05	1	
2-18	07102007210	SHIM, 15.2X20X.10	1	
2-18	07102007220	SHIM, 15.2X20X.15	1	
2-18	07102007230	SHIM, 0.20	1	
2-18	07111600240	SHIM, 0.30	1	
2-21	0720138A90	CRANKCASE, ASS'Y	1	
2-22	99961600200	BEARING, BALL, #6002	1	
2-23	99961620200	BEARING, BALL, #6202	1	
2-24	99966122206	SEAL, OIL, #TC12227	1	
2-25	99966152511	SEAL, OIL, #VE15X25X7	1	
2-26	09001380200	GASKET, CRANKCASE	1	
2-28	99414050251	SCREW, 5X25	4	
2-35	35910112203	WASHER, CLUTCH B	1	
2-36	7980166R90	PULLEY, STARTER, ASS'Y	1	
2-38	7900162V200	SPRING, PAWL, STARTER	1	
2-39	7880138A20	PAWL, STARTER	1	
2-41	1672196080	COIL, IGNITION	1	
2-44	99416040226	SCREW, WS, 4X22	2	
2-45	1120136022	CASE, FAN (ORANGE)	1	
2-45	11201442200	CASE, FAN (POLISHED)	1	
2-47	99414050181	SCREW, S, 5X18	4	
2-48	13201300200	PAN, FLASH	1	
2-49	2030604A202	GROMMET	1	
2-55	1552173380	ROTOR, MAGNETO	1	
2-56	99201080011	WASHER, 8	1	
2-57	99101080011	NUT, 8	1	
2-65	2740137G800	CORD, EARTH 150	1	

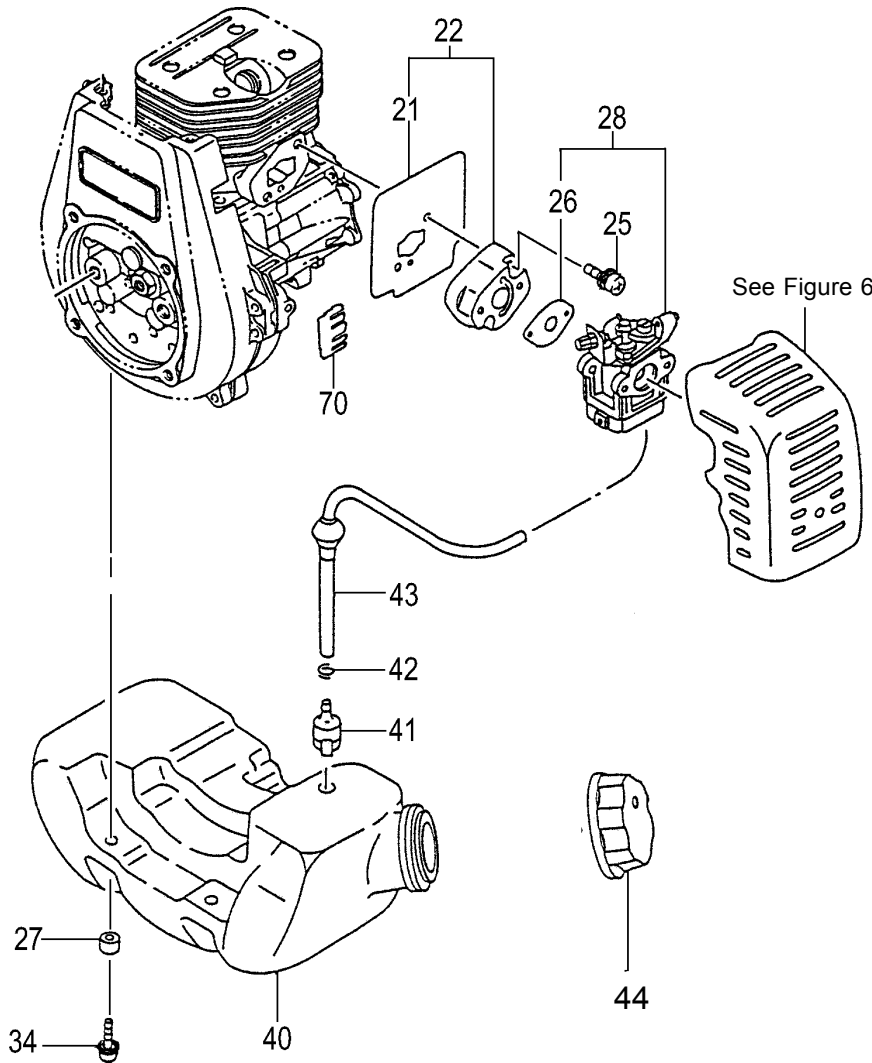

MOBY 35 Air Filter Kit
Part#: 30941



MOBY 35 Billet Gas Caps
Part#: Red - 31263
Black - 31264 / Polished - 31266

ITEM	PART NUMBER	DESCRIPTION	QTY	COMMENTS
3-21	4030143C21	GASKET,INLET MANIFOLD	1	
3-22	4040143C90	INSULATOR SET	1	
3-25	99416050221	SCREW,5X22/WS	2	
3-26	4020602K21	GASKET,CARBURETOR	1	
3-27	65900801200	COLLAR	3	
3-28	4550143C90	CARBURETOR SET	1	
3-34	99415050185	SCREW,5X18	3	
3-40	5910138A20	TANK,FUEL (ORANGE)	1	
3-40	5910130A20	TANK,FUEL (WHITE)	1	
3-41	67501630900	FILTER,FUEL	1	
3-42	68000731201	CLIP 6.3	1	
3-43	2230622U900	PIPE,FUEL,ASS'Y	1	
3-44	5950138090	CAP,TANK ASSY, (ORANGE)	1	
3-44	5950144D90	CAP,TANK ASSY, (BLACK)	1	
3-70	0910130020	PARTITION	1	
3-76	62632810200	CHAIN,TANK CAP	1	

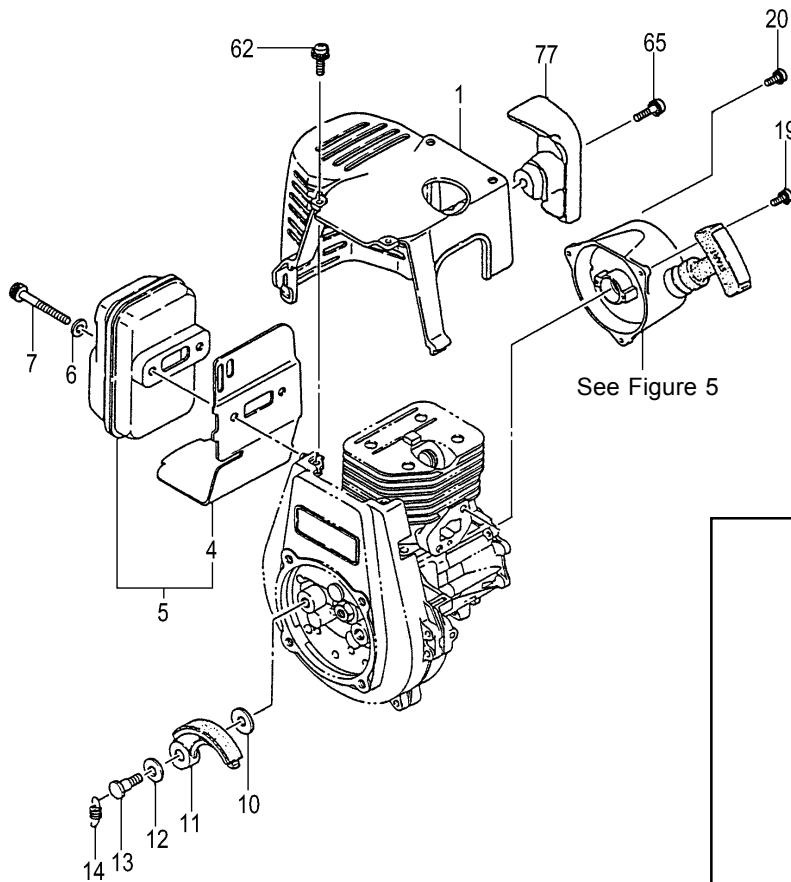

Click on the pipe for more information !!



ITEM	PART NUMBER	DESCRIPTION	QTY	COMMENTS
4-1	7380138021	PROTECTOR,MUFFLER	1	
4-4	1330138021	SHIELD,HEAT	1	
4-5	7040143C90	MUFFLER SET	1	
4-6	99201060011	WASHER,6	2	
4-7	99053060603	BOLT,HEX,6X60	2	
4-10	35910112203	WASHER,CLUTCH B	2	
4-11	2900138A80	SHOE,CLUTCH	2	
4-12	35810112201	WASHER,CLUTCH	2	
4-13	3570136U200	BOLT,STEP,CLUTCH	2	
4-14	3420138A20	SPRING,CLUTCH	1	
4-19	99416040161	SCREW 4 X 16 /WS	2	
4-20	99416040251	SCREW,4X25/WS	1	
4-62	99415040121	SCREW,PS,4X12	2	
4-65	99415050251	SCREW,5X25PS	1	
4-77	1320130A20	DEFLECTOR, AIR	1	

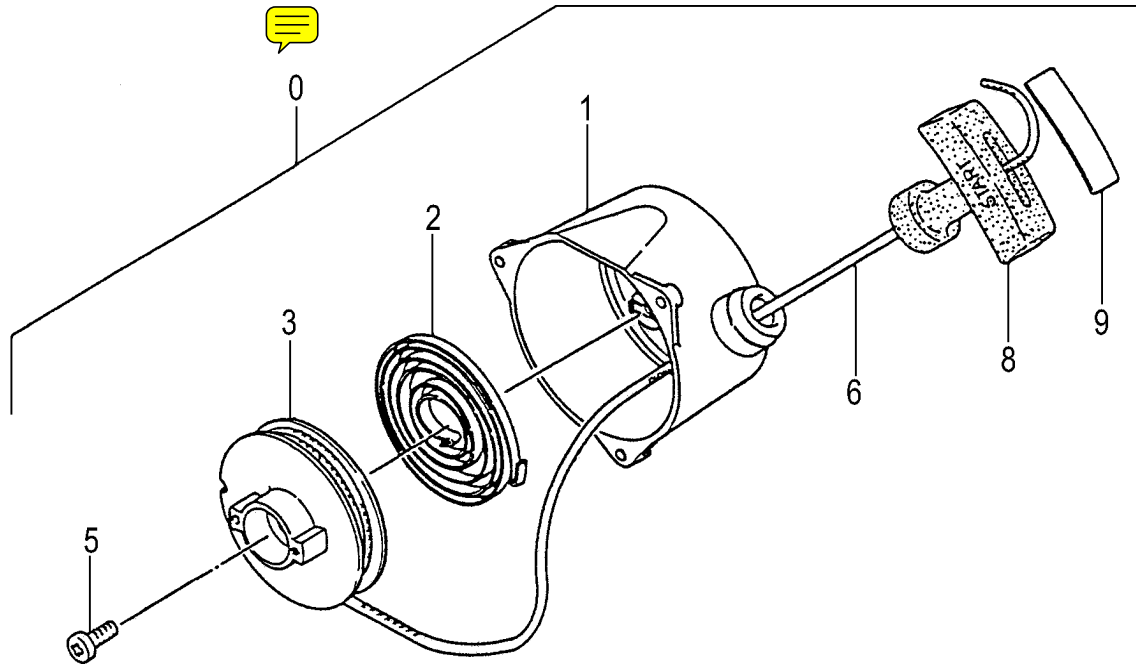

Billet Starter Handles

Part#: Blue - 31352 / Black - 31358

Polished - 31357 / Red - 31356

ITEM	PART NUMBER	DESCRIPTION	QTY	COMMENTS
5-0	7620136U901	STARTER,RECOIL ASS'Y	1	
5-1	7720136U80	BODY,STARTER	1	
5-2	7790136U200	SPRING,RECOIL	1	
5-3	7740162V200	REEL,STARTER ROPE	1	
5-5	8390201020	SCREW,SET	1	
5-6	7830136U200	ROPE,STARTER	1	
5-8	78501620200	HANDLE,STARTER	1	
5-9	79501620200	SEAL,HANDLE KNOB	1	

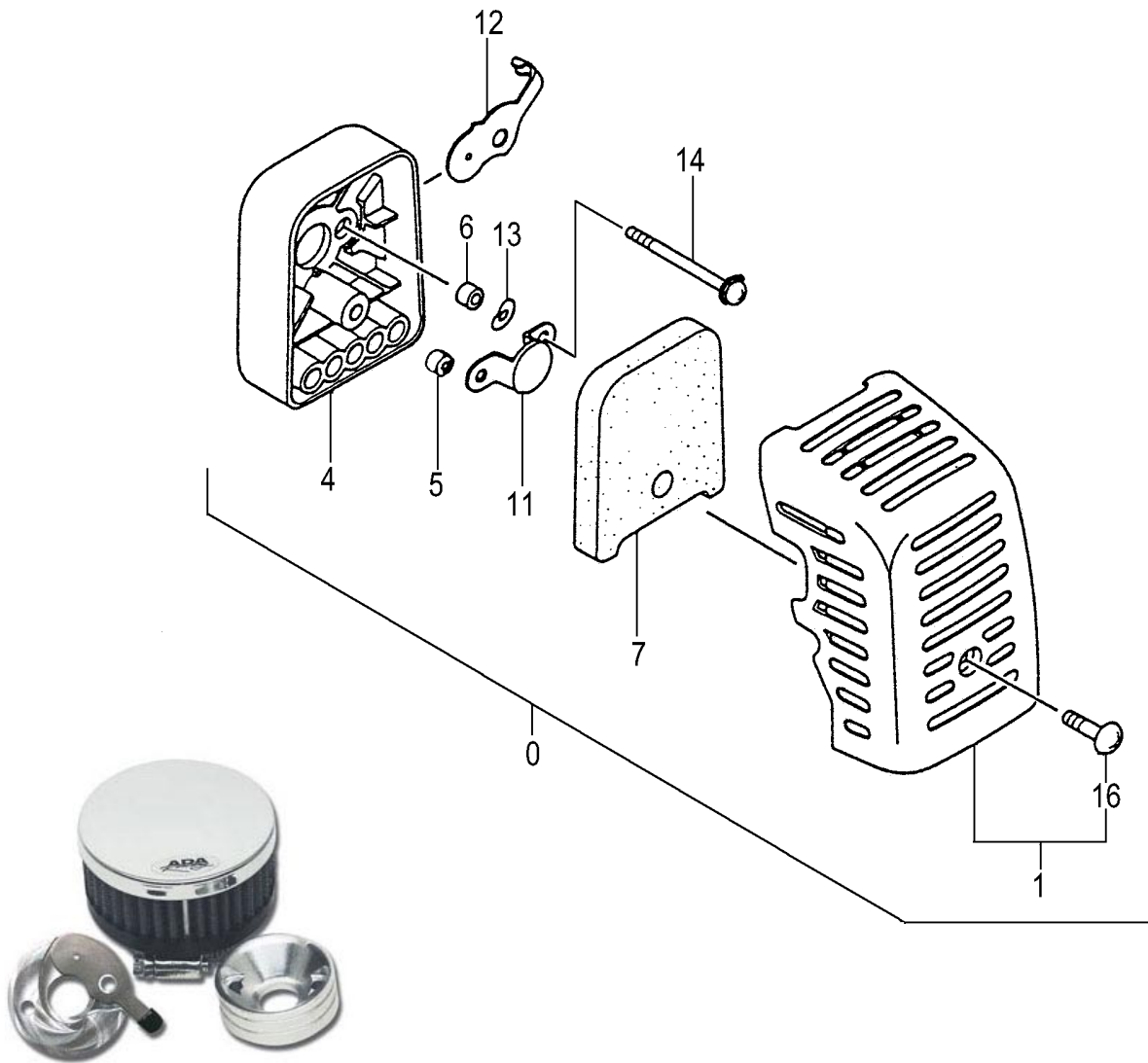

MOBY 35 Air Filter Kit

Part#: 30941

ITEM	PART NUMBER	DESCRIPTION	QTY	COMMENTS
6-0	4100138A93	CLEANER ASSY	1	
6-1	4520138091	COVER,CLEANER,ASSY	1	
6-4	4230138082	BODY,CLEANER	1	
6-5	4530637C200	COLLAR	1	
6-6	4700602N200	COLLAR,CLEANER	1	
6-7	4460138020	ELEMENT,CLEANER	1	
6-11	47601700200	BOARD,BLOW OVER CHECK	1	
6-12	5280138021	VALVE,CHOKE	1	
6-13	99204080030	WASHER	1	
6-14	99414050571	SCREW,5X5,S	2	
6-16	3800637C200	BOLT,CLEANER COVER	1	

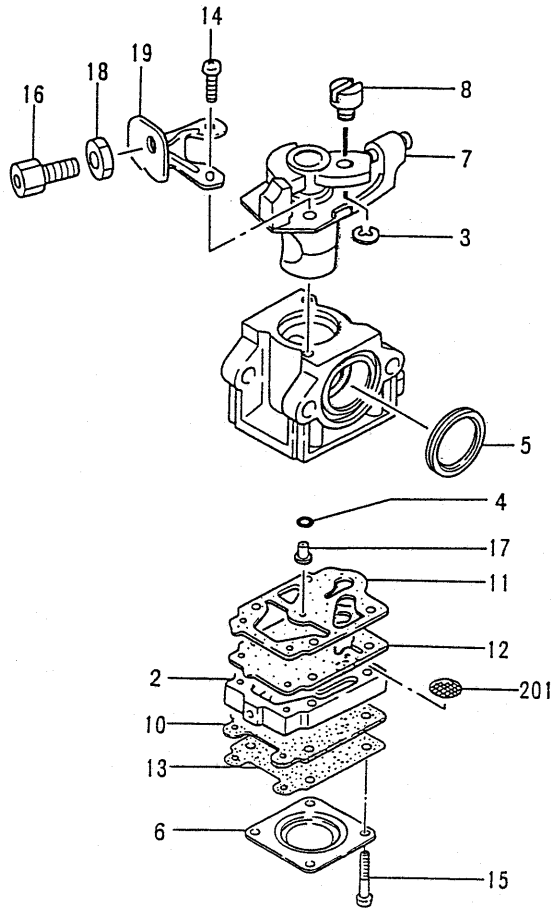

35cc HP Carburetor Kit
Part#: 31281

ITEM	PART NUMBER	DESCRIPTION	QTY	COMMENTS
	4550143C90	CARBURETOR SET	1	Includes gasket
7-2	5752515280	BODY,PUMP	1	
7-3	48925100200	RING,STOP	1	
7-4	55025100200	O-RING	1	
7-5	4310634C200	GASKET,CLEANER	1	
7-6	47625004200	COVER,DIAPHRAGM	1	
7-7	48825120900	VALVE,THROTTLE	1	
7-8	53925120200	SWIVEL	1	
7-10	~ ~ ~	GASKET,DIAPHRAGM	1	~ Not available individually - order 650.25124.900 Carb Kit
7-11	~ ~ ~	GASKET,PUMP	1	
7-12	~ ~ ~	DIAPHRAGM,PUMP	1	
7-13	~ ~ ~	DIAPHRAGM,METERING	1	
7-14	51425100200	SCREW,THROTTLE SET	2	
7-15	54825101200	SCREW,SET	4	
7-16	61425137200	ADJUSTER,CABLE	1	
7-17	5992000W430	JET,MAIN,#43	1	
7-18	99101060013	NUT,6	1	
7-19	54425120200	STAY,ADJUST,CABLE	1	
7-201	57825007200	SCREEN,INLET	1	

Belt Adjustment



Figure 15

The Moby PowerBoard uses a dual stage, belt driven system to transmit power to the rear wheel. Belts should be regularly inspected for adjustment. Both belts are adjusted with two procedures.

Tighten both belt adjusters on either side of the frame (**Fig. 15**) in equal increments until the small belt has approximately ½ inch of play when measured between the pulleys.

Next, loosen the rear axle lock nut, using a 17mm wrench or socket. Adjust the tension in the larger belt by using the rear wheel adjusters located at the rear of the frame, behind the wheel (**Fig. 16**). The belt should have approximately ½ inch of play. Make sure that the wheel is lined up in the center of the frame.

After adjustment, test ride the unit for a short distance to ensure that the belts ride in the center of their pulleys. If they tend to ride on one side of the pulley(s), adjust the opposite side adjuster until the belt centers on the pulley, being careful to maintain the correct belt tension.



Figure 16

Belt Replacement



Figure 17

Both drive belts carry a similar load, and should wear at a very similar rate. If one of the belts should break or one or both appear worn to the point of needing replacement, it may be preferable to replace both belts simultaneously, as the repair is somewhat involved.



Figure 18

To replace the belts begin by removing the air cleaner cover, and disconnect the throttle wire and stop cord wire from engine.

Next, remove the 2 top engine mount bolts with their spacers, as well as the fender (**Fig. 17**).

Loosen and remove the belt tension adjuster from the left side of the frame, as well as the three screws that secure the left hand side plate to the frame (**Fig. 18**)



Figure 19

With the side plate removed, it is possible to remove both belts from the frontward pulleys. Inspect the pulleys (**Fig. 19**) to ensure that they are not damaged. Also, inspect the bearings on the pulley shaft as well as the support bearing that rides in the side plate. If integrity of any bearings are questionable – install new ones.

If it is necessary to replace the large, rear belt, it will require that the rear wheel be completely removed.

Carefully position new belt(s). Note that the lower section of the large, rear belt must ride on top of the idler arm (with two ball bearings in tandem), protruding from the side plate.

Carefully adjust the tension of the belts as indicated in the previous section.