

## Angle Grinder - 0 601 301 039 - USW(J)77..S 3

www.powertools-aftersaleservice.com



**BOSCH**

Item	Part Number	Description	Illustration	Price	Quantity	Price Group
	1 1 605 108 042	Motor Housing	1	-,-	1	-
	2 1 604 336 006	Brush Holder	1	-,-	1	29
	3 1 604 010 034	Armature 110-115V	1	-,-	1	-
	4 1 600 209 002	Air-Deflector Ring	1	-,-	1	14
	5 3 605 806 132	Gear Housing	1	-,-	1	47
	6 1 603 523 034	Grinding Spindle	1	-,-	1	52
6/01	1 603 523 091	Grinding Spindle 5/8"-UNC-2A	N/A	-,-	1	38
	7 1 600 109 002	Cupped Washer	1	-,-	1	11
	8 1 600 521 013	Conical Spring Washer	1	-,-	1	22
	9 3 607 030 375	Bearing Flange	1	-,-	1	50
	10 1 900 210 146	O-Ring 45x3MM	1	-,-	1	16
	11 1 600 328 012	Connecting Flange	1	-,-	1	-
	12 1 607 415 002	Shut-Off Tap	1	-,-	1	38
	13 1 600 113 002	Seal	1	-,-	1	11
	14 3 605 132 048	Handle DARK BLUE	N/A	-,-	1	40
14/1	1 601 014 000	Sealing Cord	N/A	-,-	1	13
	15 3 600 703 011	Grommet Ø9,2-Ø12x120 MM	1	-,-	1	13
	16 1 604 460 203	Power supply cord GB 110V 4,15m 2 x 1,5mm H07RN-F	1	-,-	1	34
	17 1 607 000 034	Switch Kit	1	-,-	1	33
	18 1 604 220 029	Pole Shoe 110-115V	1	-,-	1	-
	19 1 602 026 030	Control Lever	N/A	-,-	1	19
	21 1 604 652 015	Spiral Spring	1	-,-	2	11
	22 3 605 500 057	Sealing cap BLUE	1	-,-	2	-
	23 1 601 106 032	Nameplate 26x52 MM	N/A	-,-	1	13
	24 1 600 108 048	Sealing disk	1	-,-	2	11
	25 2 916 620 011	Retaining ring Ø22 MM	N/A	-,-	1	11
	26 1 600 210 005	O-Ring 66,0x3,0 MM	1	-,-	1	12
	27 1 600 102 638	Shim 0,05 MM THICK	1	-,-	1	15
	27 1 600 102 639	Shim 0,1 MM THICK	1	-,-	1	12
	27 1 600 102 640	Shim 0,15 MM THICK	1	-,-	1	12
	28 2 916 660 021	Spring retaining ring 47x1,75MM, DIN 472	1	-,-	2	16
	29 1 601 110 003	Manufacturer's nameplate	1	-,-	2	11
	33 2 600 910 001	Needle bearing Ø14 MM	1	-,-	1	16

Item	Part Number	Description	Illustration	Price	Quantity	Price Group
34	1 900 900 352	Deep-Groove Ball Bearing 17x47x14	1	-,-	1	32
35	2 910 110 116	Pan head screw DIN 85 AM 4x6-MS	1	-,-	1	10
36	2 910 011 164	Socket head cap screw DIN 84-AM5x25-5.8	1	-,-	3	10
37	2 910 011 160	Socket head cap screw AM 5x18 DIN 84-5.8	1	-,-	4	-
38	2 910 021 165	Socket head cap screw DIN 84-AM5x28-8.8	1	-,-	4	-
39	2 916 690 004	Spring Lock Washer DIN 128-A5-FST	1	-,-	2	11
40	2 910 021 050	Socket head cap screw DIN 84-AM3x8-8.8	1	-,-	2	10
41	2 910 011 122	Socket head cap screw DIN 84-AM4x12-5.8	1	-,-	2	-
42	2 916 060 003	Spring Washer A 3 DIN 137-ST	1	-,-	2	10
43	2 916 010 410	Plain Washer A 4,3 DIN 125-ST	1	-,-	1	10
45	2 916 011 006	Plain Washer DIN 125-A3,2-ST	1	-,-	2	10
46	2 910 011 157	Socket head cap screw DIN 84-AM5x15-5.8	1	-,-	4	10
47	1 603 410 008	Socket head cap screw	1	-,-	2	-
48	2 910 021 125	Socket head cap screw DIN 84-AM4x15-8.8	1	-,-	2	10
49	2 910 021 130	Socket head cap screw DIN 84-AM4x20-8.8	1	-,-	3	10
51	1 600 150 006	Spring Washer DIN 137-A4	1	-,-	3	13
52	2 910 011 120	Socket head cap screw DIN 84-AM4x10-5.8	1	-,-	2	10
54	2 910 211 019	Tapping Screw DIN 7971-ST3,9x16-F	1	-,-	2	10
55	2 910 211 004	Tapping Screw DIN 7971-BZ2,9x6,5	1	-,-	2	11
56	1 601 302 013	Fastening Clamp	1	-,-	1	11
57	1 000 202 026	O-Ring	1	-,-	1	-
58	2 915 011 012	Hex Nut DIN 934-M 14-6G	1	-,-	1	16
69	1 600 205 008	Felt Washer	1	-,-	1	11
70	1 601 014 000	Sealing Cord	N/A	-,-	1	13
71	1 600 108 018	Felt Disc	N/A	-,-	1	11
72	1 600 501 019	Bearing cover	N/A	-,-	1	25
73	1 600 900 020	Deep-Groove Ball Bearing 17x35x10	N/A	-,-	1	38
74	1 603 344 030	Threaded Ring	N/A	-,-	1	40
75	1 600 101 641	Shim 0,3 MM THICK	1	-,-	1	13
76	1 600 101 648	Shim 0,1 MM THICK	N/A	-,-	1	11
76	1 600 101 649	Shim 0,15 MM THICK	N/A	-,-	1	-
76	1 600 101 650	Shim 0,05 MM THICK	N/A	-,-	1	11
76	1 600 102 002	Shim	N/A	-,-	1	-
77	3 605 820 064	Bearing Flange	N/A	-,-	1	41
78	1 600 501 024	Cover Disc	N/A	-,-	1	23
79	2 910 511 130	Countersunk-Head Screw DIN 63-AM4x20-8.8	1	-,-	3	-
80	1 420 100 023	Shim 0,10 MM THICK	N/A	-,-	1	11
81	1 900 905 018	Deep-Groove Ball Bearing 7x22x7	N/A	-,-	1	29
651	1 602 025 022	Auxiliary Handle M14 BLACK	N/A	-,-	1	26
651	1 602 025 030	Auxiliary Handle M14, Ø37x115 MM BLACK	N/A	-,-	1	28
700	1 606 333 082	Bevel Gear Z=54	N/A	-,-	1	45
801	1 607 014 102	Carbon-Brush Set	1	-,-	1	23
803	1 602 388 007	Sealing Plate	N/A	-,-	1	22
810	1 607 000 058	Seal Kit	N/A	-,-	1	22
811	1 607 000 044	Seal Kit	N/A	-,-	1	19

Illustration - Type E

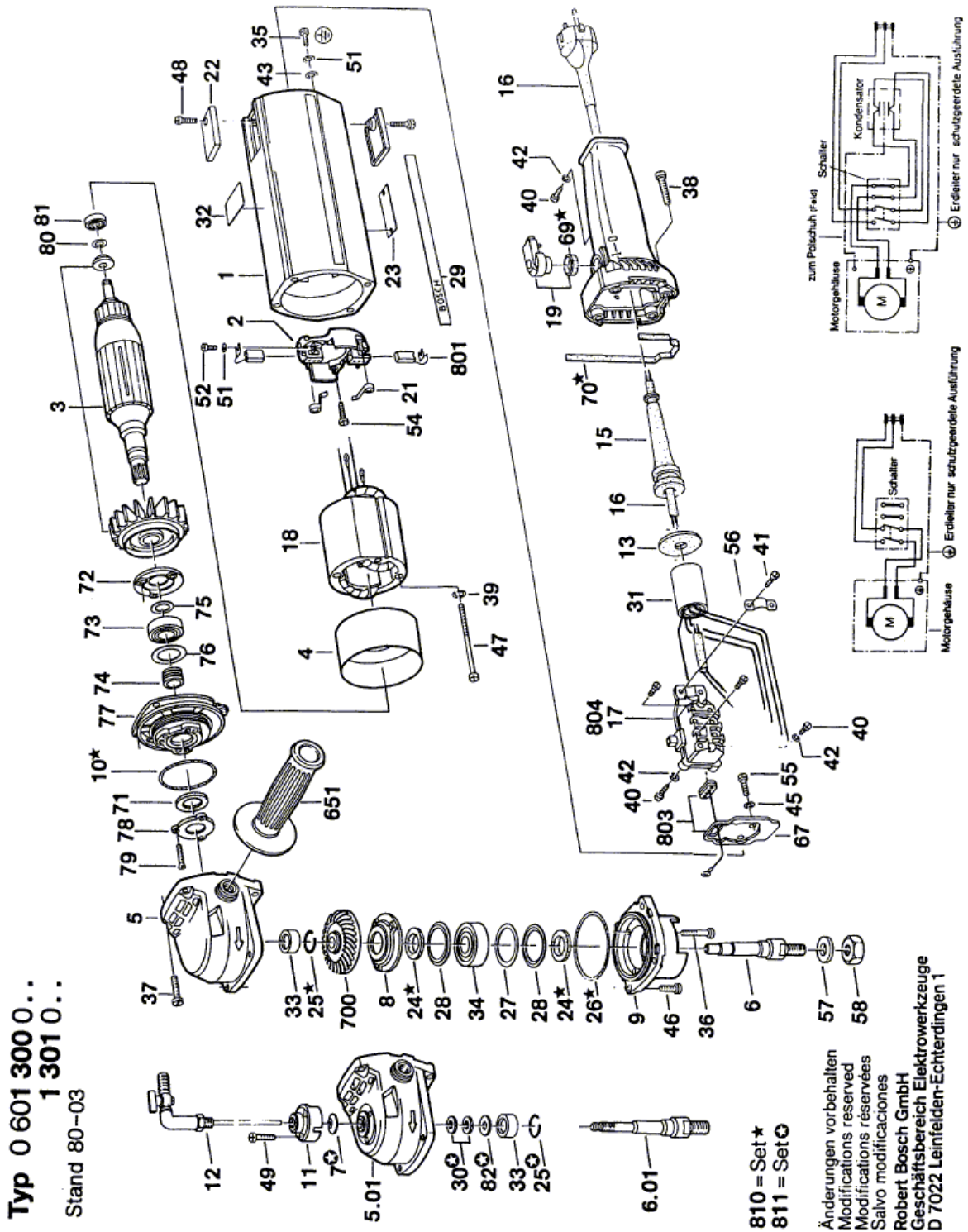

Information subject to change without further notice.