



SERVICE PARTS LIST

BUL. 54-06-0804

1/4" PISTOL DRILL

REVISED BUL 54-06-0803 DATE July '72

Catalog No. 0140

Starting Serial No. **91-7034**

WIRING INSTR. **58-01-0010**

Both Model and Serial No. must be furnished to obtain correct parts.

3500 R.P.M.

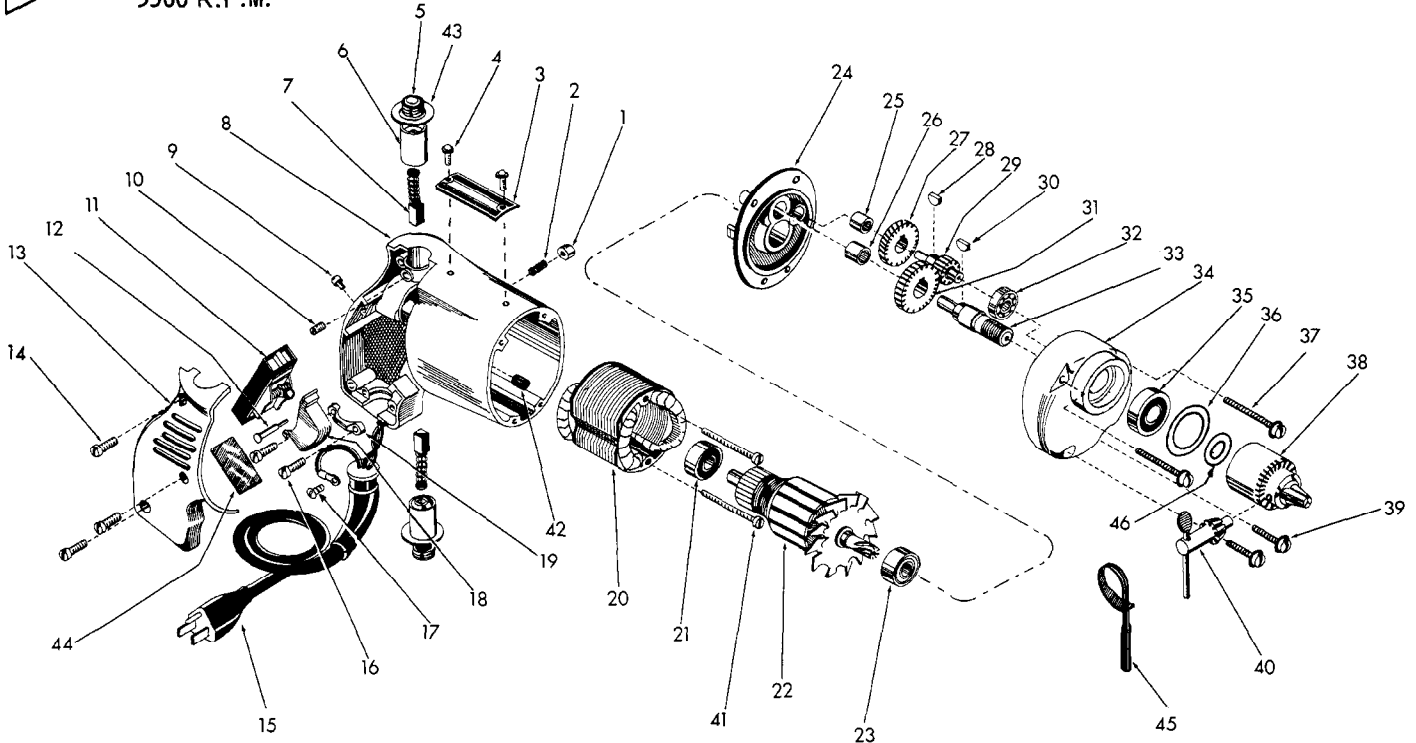

FIG.	PART NO.	DESCRIPTION OF PART	NO.REQ.
	1	42-42-0061 Trigger Lock Button	
	2	40-50-1200 Trigger Lock Spring	
★	3	12-99-0020 Name Plate	
	4	06-85-0200 Name Plate Screw (2)	(2)
	5	23-44-0020 Brush Retaining Cap (2)	(2)
	6	22-22-0050 Brush Holder Assembly (2)	(2)
	7	22-18-0090 Carbon Brush Assembly (2)	(2)
	8	28-50-4447 Motor Hsg. (Inc. Fig. Nos. 1, 2, 12, 13, 14 & 42)	
	9	06-81-5800 6-32 x 5/16 Fil. Hd. Sems	
	10	06-83-2430 10-32 x 1/4 Skt. Hd. Set Screw (2)	(2)
	11	23-66-0280 Switch	
		06-97-1800 Switch Lock Washers (4)	(4)
	12	44-70-0071 Trigger Lock Shaft	
	13	28-20-3002 Handle Cover	
	14	06-81-6150 8-32 x 1/2 Fil. Hd. Sems (3)	(3)
	15	22-64-0170 Cord Set	
	16	06-81-6150 8-32 x 1/2 Fil Hd. Sems (2)	(2)
	17	06-81-8625 Ground Screw	
★	18	31-92-0102 Switch Trigger	
	19	28-17-0400 Cord Clamp	
	20	18-22-1030 Field	
	21	02-04-0740 Ball Bearing	
	22	16-22-1120 Armature Assembly	
	23	02-04-0880 Ball Bearing	

FIG.	PART NO.	DESCRIPTION OF PART	NO.REQ.
	24	28-28-0221 Diaphragm	
	25	02-50-1210 Needle Bearing	
	26	02-50-1640 Needle Bearing	
	27	32-40-1041 Intermediate Gear	
	28	06-42-0400 Woodruff Key	
	29	36-66-1351 Intermediate Pinion Shaft	
	30	06-42-0800 Woodruff Key	
	31	32-75-1281 Spindle Gear	
	32	02-04-0640 Intermediate Shaft Ball Bearing	
	33	38-50-1051 Spindle	
★	34	28-14-0363 Gear Case	
	35	02-04-1020 Ball Bearing	
★	36	34-80-1400 Retaining Ring	
★	37	06-81-6575 8-32 x 1-5/8 Fil. Hd. Sems (2)	(2)
	38	48-66-0260 Chuck	
★	39	06-81-6350 8-32 x 1 Fil. Hd. Sems (2)	(2)
	40	48-66-3200 Chuck Key	
	41	06-81-5950 6-32 x 1-7/8 Fil. Hd. Screws (2)	(2)
	42	45-30-0060 Ball Bearing Ret. Slug	
★	43	23-86-0105 Insulating Washer (2)	(2)
	44	23-16-0265 Switch Insulator	
	45	48-66-4080 Key Holder	
★	46	45-88-0080 Chuck Washer	