



SERVICE PARTS LIST

BULLETIN NO.
54-06-0860

SPECIFY CATALOG NO. AND SERIAL NO. WHEN ORDERING PARTS		REVISED BULLETIN	DATE
1/2" KEYLESS CHUCK HOLE-SHOOTER			April '88
CATALOG NO. 0239-1	STARTING SERIAL NO. 756-1001	WIRING INSTRUCTION 58-01-0015	

EXAMPLE:



Component Parts (Small #)
Are Included When Ordering
The Assembly (Large #).

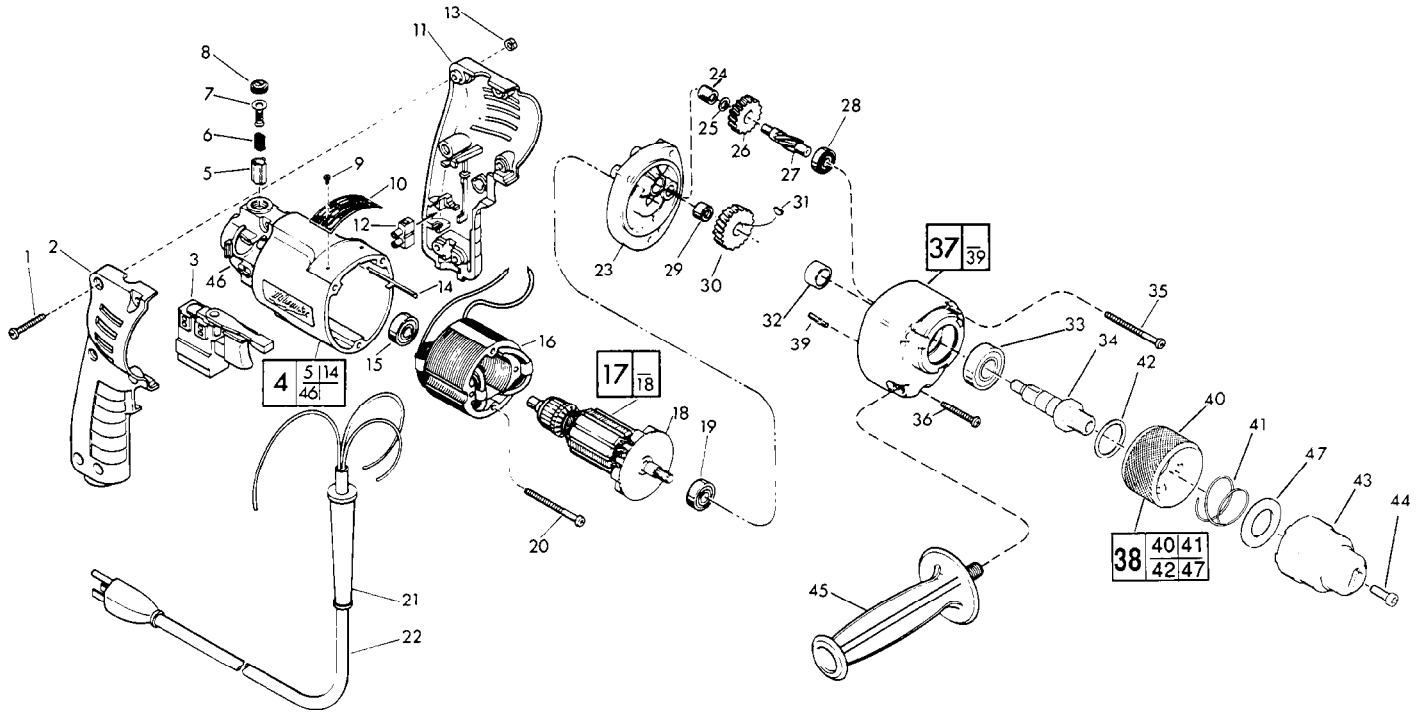

FIG.	PART NO.	DESCRIPTION	NO. REQ.
1	06-82-2361	8-32x15/16" Pan Hd. Slit. Torx Screw	(6)
2	31-44-1130	Right Handle Half	(1)
3	23-66-1245	Trigger Speed Control Switch	(1)
4	14-38-0375	Motor Housing Assembly	(1)
5	22-20-0530	Brush Tube	(2)
6	22-16-0275	Carbon Brush	(2)
7	23-52-0210	Brush Spring Assembly	(2)
8	23-44-0120	Brush Retaining Screw	(2)
9	06-85-0200	Nameplate Screw	(2)
10	12-99-0420	Nameplate Blank	(1)
11	31-44-1140	Left Handle Half	(1)
12	22-56-0456	Terminal Block	(1)
13	06-55-0835	8-32 Hex Nut	(6)
14	44-60-0530	Ground Pin	(1)
15	02-04-0645	Ball Bearing	(1)
16	18-10-0130	120 Volt Field	(1)
17	16-10-0545	120 Volt Armature	(1)
18	22-84-0440	Fan Assembly	(1)
19	02-04-0847	Ball Bearing	(1)
20	06-82-7393	7-18x2" Pan Hd. Slit Plast. Torx Screw	(2)
21	44-76-0130	Cord Protector	(1)
22	22-64-1120	Cord Set	(1)
23	28-28-1810	Diaphragm	(1)
24	02-50-1210	Needle Bearing	(1)
25	45-88-7301	Heat Treat Washer	(1)
26	32-40-2010	Intermediate Gear	(1)
27	36-66-4500	Intermediate Pinion	(1)
28	02-04-0640	Ball Bearing	(1)
29	02-50-1611	Needle Bearing	(1)
30	32-75-3320	Spindle Gear	(1)

FIG.	PART NO.	DESCRIPTION	NO. REQ.
31	06-42-1200	Woodruff Key	(1)
32	45-36-1100	Spindle Spacer	(1)
33	02-04-1230	Ball Bearing	(1)
34	38-50-5740	Spindle	(1)
35	06-82-7440	7-18x2-1/2" Pan Hd. Slit. Plast. Torx	(2)
36	06-82-7344	7-18x1-1/2" Pan Hd. Slit. Plast. Torx	(1)
37	14-30-0520	Gear Case Assembly	(1)
38	14-46-1560	Collar Service Kit	(1)
39	06-65-0825	Groove Pin	(1)
40	42-76-0500	Collar Assembly	(1)
41	40-50-8125	Conical Spring	(1)
42	34-80-2300	Retaining Ring	(1)
43	48-66-1490	1/2" Keyless Chuck	(1)
44	06-75-3150	1/4-20x1" L.H. Thrd. Skt. Hd. Screw	(1)
45	43-62-0875	Side Handle	(1)
46	31-50-0346	Motor Housing	(1)
47	45-88-1125	Nylon Washer	(1)
	10-98-6465	Bi-Lingual Label	(1)

FIG. LUBRICATION

37 1.5 Oz. Type "E" Grease, 49-08-4121. Place Grease Near Intermediate Shaft Ball Bearing In Gear Case.

FIG. NOTES

34 Apply Blue Loctite To Internal Threads Prior To Chuck Assembly
43 Ratchet Chuck (15-20 In./Lbs. Collar Load) To Secure Chuck To Spindle.