



SERVICE PARTS LIST

BULLETIN NO.
55-06-1852

SPECIFY CATALOG NO. AND SERIAL NO. WHEN ORDERING PARTS		REVISED BULLETIN 55-06-1851	DATE April '95
VARIABLE SPEED 3/8" CORDLESS DRIVER/DRILL			
CATALOG NO.	0396-4	STARTING SERIAL NO.	783B
		WIRING INSTRUCTION 58-01-1241	

EXAMPLE:
Component Parts (Small #)
Are Included When Ordering
The Assembly (Large #).

00 0

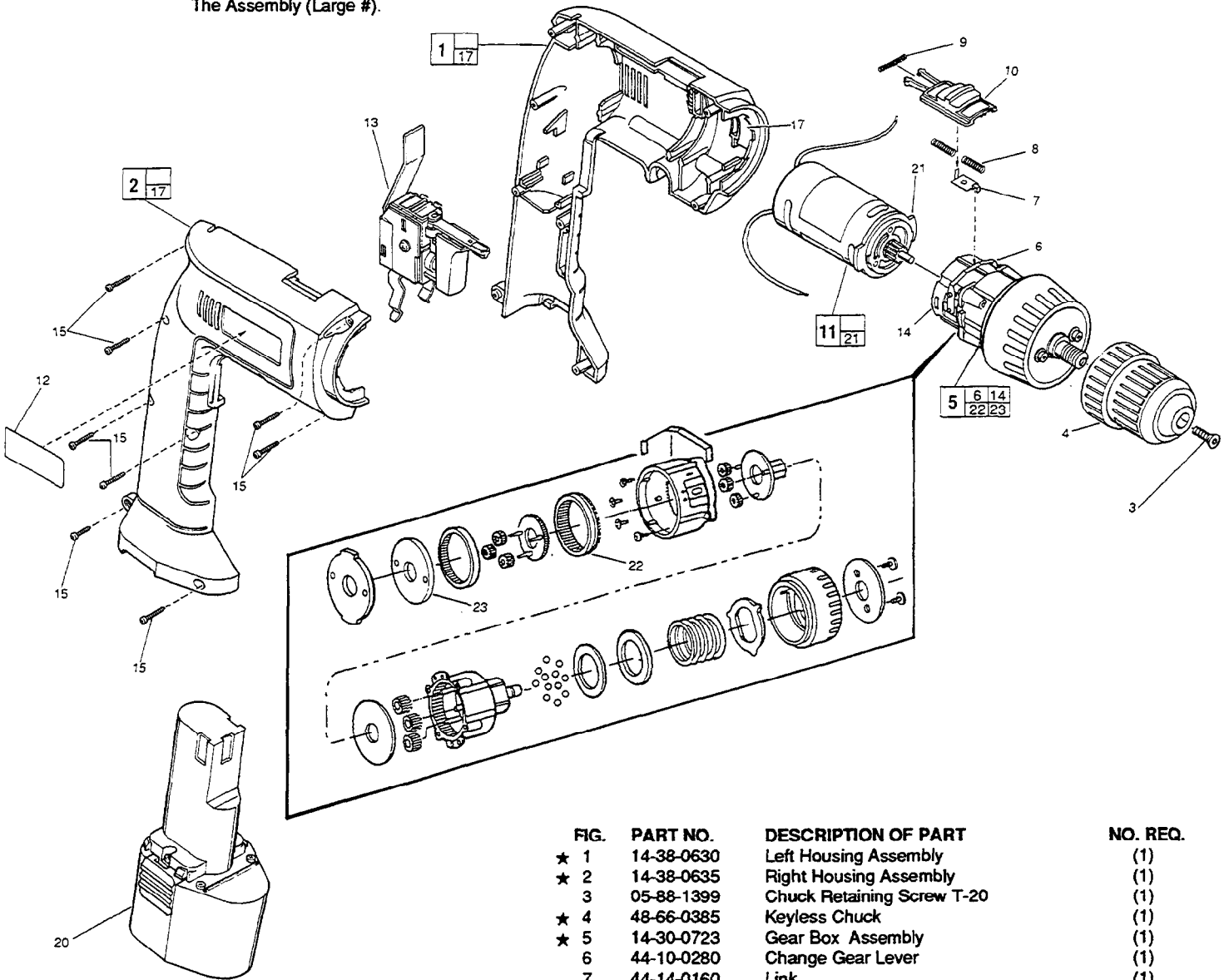

FIG.	PART NO.	DESCRIPTION OF PART	NO. REQ.
★ 1	14-38-0630	Left Housing Assembly	(1)
★ 2	14-38-0635	Right Housing Assembly	(1)
★ 3	05-88-1399	Chuck Retaining Screw T-20	(1)
★ 4	48-66-0385	Keyless Chuck	(1)
★ 5	14-30-0723	Gear Box Assembly	(1)
★ 6	44-10-0280	Change Gear Lever	(1)
★ 7	44-14-0160	Link	(1)
★ 8	40-50-8300	Spring	(2)
★ 9	40-50-8310	Spring	(1)
★ 10	45-24-0070	Slide - High/Low	(1)
★ 11	14-50-0610	Motor Assembly	(1)
★ 12	—	Service Nameplate Kit	(1)
★ 13	23-66-2300	Variable Speed Switch	(1)
★ 14	31-50-0770	Gear Housing	(1)
★ 15	06-82-7236	4-20 x 5/8" Plastite Pan Hd. Torx T-10	(8)
★ 17	44-52-0440	Foam Pad	(2)
★ 20	—	9.6 V. Battery Pack - Select From Catalog	(1)
★ 21	44-66-0850	Motor Mount Plate	(1)
★ 22	32-65-0050	Shift Lever Ring Gear	(1)
★ 23	45-88-8590	Thrust Washer	(1)