



SERVICE PARTS LIST

BUL.54-08-0652

3/8" ELECTRIC DRILL

REVISED BUL
54-08-0652

DATE
Feb.'70

Catalog No. 0890

Starting
Serial No. 50-9145

WIRING INSTR.

58-01-0170

Both Model and Serial No. must be furnished to obtain correct parts.

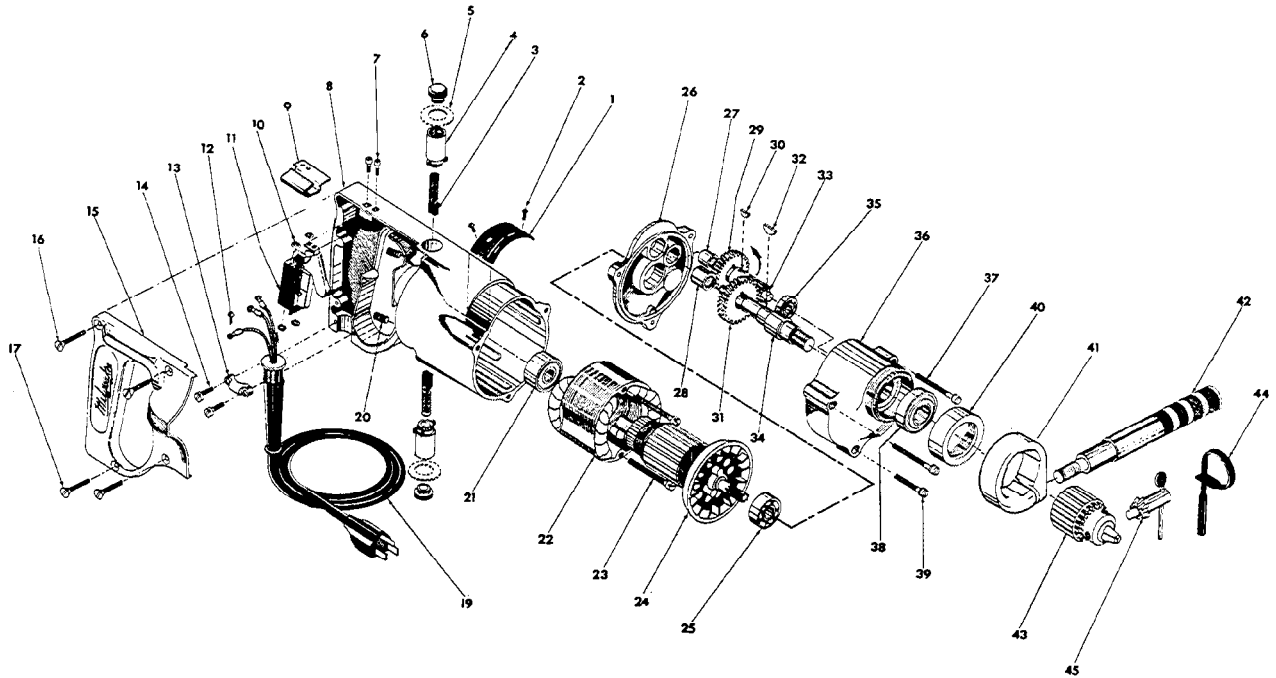

FIG.	PART NO.	DESCRIPTION OF PART	NO.REQ.	FIG.	PART NO.	DESCRIPTION OF PART	NO.REQ.
	1	12-98-0800 Name Plate		24	16-42-1040	Armature Assy.	
★	2	06-77-0625 6x1/4 Rd. Driv-In Screw	(2)	25	02-04-0940	Ball Bearing (Pinion End)	
	3	22-18-0100 Carbon Brush Assy.	(2)	26	28-28-0581	Diaphragm	
	4	22-22-0080 Brush Holder Assy.	(2)	27	02-50-1640	Needle Bearing	
	5	23-86-0110 Brush Holder Insul. Washer	(2)	28	02-50-2110	Needle Bearing	
	6	23-44-0060 Brush Retaining Screw	(2)	29	32-40-1241	Intermediate Gear	
	7	06-81-5800 6-32x5/16 Fil. Hd. Sem Sw. Mtg. Scrs.	(2)	30	06-42-0800	Woodruff Key	
	8	28-50-4481 Motor Housing Assy. (Incl. Items 15, 16 & 17)		31	32-75-2001	Spindle Gear	
★	9	42-68-0225 Wire Clamp		32	06-42-1200	Woodruff Key	
	10	06-97-1800 Lock Washers	(4)	33	36-66-2701	Intermediate Pinion Shaft	
	11	23-66-0230 Switch		34	38-50-2551	Spindle	
	12	06-81-8625 6-32x1/4 Rd. Hd. Sem (Bronze) Ground Scr.		35	02-04-0640	Ball Bearing	
	13	28-17-0400 Cord Clamp		36	28-14-0681	Gear Case	
	14	06-81-6150 8-32x1/2 Fil. Hd. Sem Cord Clamp Scrs.	(2)	37	06-81-6650	8-32x1-3/4 Fil. Hd. Sem Gear Case Scrs.	(2)
★	15	28-20-3601 Handle Cover		38	02-04-1560	Ball Bearing	
	16	06-81-3750 8-32x1 Oval Hd. Handle Cover Scrs.	(2)	39	06-81-6350	8-32x1 Fil. Hd. Sem Gear Case Scr.	
	17	06-81-3700 8-32x7/8 Oval Hd. Handle Cover Scrs.	(2)	40	42-52-0071	Bearing Cap	
	19	22-64-0170 Cord Set		★41	28-82-0130	Handle Ring	
	20	06-83-2650 1/4-20x3/8 Hd'less Brush Holder Set Scrs	(2)	42	43-62-0160	Handle	
	21	02-04-0970 Ball Bearing (Comm. End)		43	48-66-0840	Chuck	
★	22	18-42-1040 Field Assy.		44	48-66-4040	Key Holder	
	23	06-81-6600 8-32x1-3/4 Fil. Hd. Sem Field Scrs.	(2)	45	48-66-3280	Chuck Key	