



SERVICE PARTS LIST

BUL. 54-08-1104

1/2" DRILL

REVISED BUL.
54-08-1103

DATE
March '79

Catalog No. 1001

Starting
Serial No. 490-18300

WIRING INSTRUCTIONS
58-01-0182

Specify Catalog and Serial No. when ordering parts

600 R.P.M.
4.5 AMPS

FOR CAT. NO. 1001-2
(240V) TOOL USE:
18-36-0200 FIELD
16-36-0305 ARMATURE
22-16-0255 CARBON BRUSH
22-64-4100 CORD SET

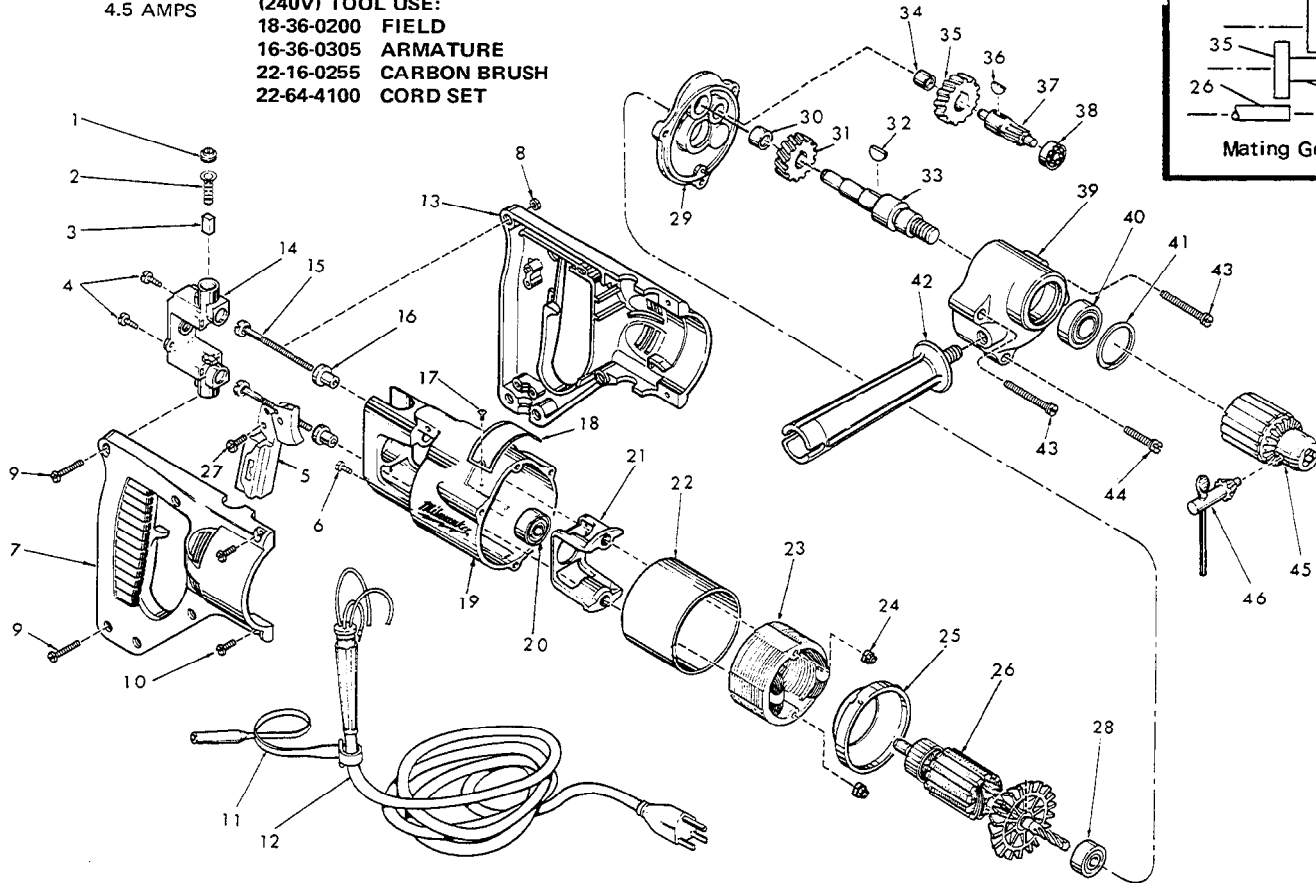

FIG.	PART NO.	DESCRIPTION OF PART	NO. REQ.	FIG.	PART NO.	DESCRIPTION OF PART	NO. REQ.
1	23-44-0120	Brush Retaining Screw	(2)	25	31-05-0050	Baffle	(1)
2	23-52-0160	Brush Spring	(2)	26	16-30-0305	120 V. Armature	(1)
3	22-16-0250	Carbon Brush	(2)	27	06-95-0215	8-18x1/2 Thread Form Screw	(1)
4	06-81-5477	6-32x3/8 Phillips Pan Hd. Sem	(2)	28	02-04-0940	Ball Bearing	(1)
5	23-66-0505	Switch	(1)	29	28-28-0582	Diaphragm	(1)
6	06-81-8625	6-32x1/4 Ground Screw	(1)	30	02-50-2110	Needle Bearing	(1)
7	31-44-0562	R.H. Half D Handle	(1)	31	32-75-1601	Spindle Gear	(1)
8	06-55-0825	8-32 Hex Nut	(5)	32	06-42-1200	Woodruff Key	(1)
9	06-81-0472	8-32x1 Pan Hd. Screw	(5)	33	38-50-2551	Spindle	(1)
10	06-81-0047	8-32x1/2 Pan Hd. Screw	(4)	34	02-50-1640	Needle Bearing	(1)
11	48-66-4040	Key Holder	(1)	35	32-40-1241	Intermediate Gear	(1)
12	22-64-0405	Cord Set	(1)	36	06-42-0800	Woodruff Key	(1)
13	31-44-0572	L.H. Half D Handle	(1)	37	36-66-2001	Intermediate Shaft	(1)
14	22-22-0302	Brush Holder Assembly	(1)	38	02-04-0640	Ball Bearing	(1)
15	06-81-1055	8-32x2-3/16 Field Bolt	(2)	★39	28-14-0686	Gear Case	(1)
16	31-86-0120	Insulating Spacer	(2)	40	02-04-1560	Ball Bearing	(1)
17	06-85-0200	6x1/4 Rd. Hd. Type Z Screw	(2)	★41	34-80-2500	Retaining Ring	(1)
18	12-99-0030	Nameplate	(1)	★42	43-62-0600	Side Handle	(1)
19	28-50-6147	Motor Housing	(1)	43	06-81-6707	8-32x1-1/8 Fil. Hd. Sem	(2)
20	02-04-0891	Ball Bearing	(1)	44	06-81-6402	8-32x1-1/8 Fil. Hd. Sem	(1)
21	31-55-0030	Coil Shield	(1)	45	48-66-1280	1/2" Chuck (Includes Fig. 46)	(1)
22	23-16-0456	Field Insulator	(1)	46	48-66-3280	Chuck Key	(1)
23	18-30-0200	120 V. Field	(1)	★47	10-98-5985	Warning Label	(1)
24	06-57-2975	8-32x Flexlock Hex Nut	(2)				