

0 611 235 839

Issue } 05-02-14 **Fig./Abb. 1**
Stand }

Slipping point of clutch
Ausrastmoment 18 - 22Nm
Couple de glessement
Momento de desenclavamiento

Zahnspiel = 0,1-0,25; Ausgleich mit Pos. 101+102
Gearplay = 0,1-0,25; adjust with pos. 101+102

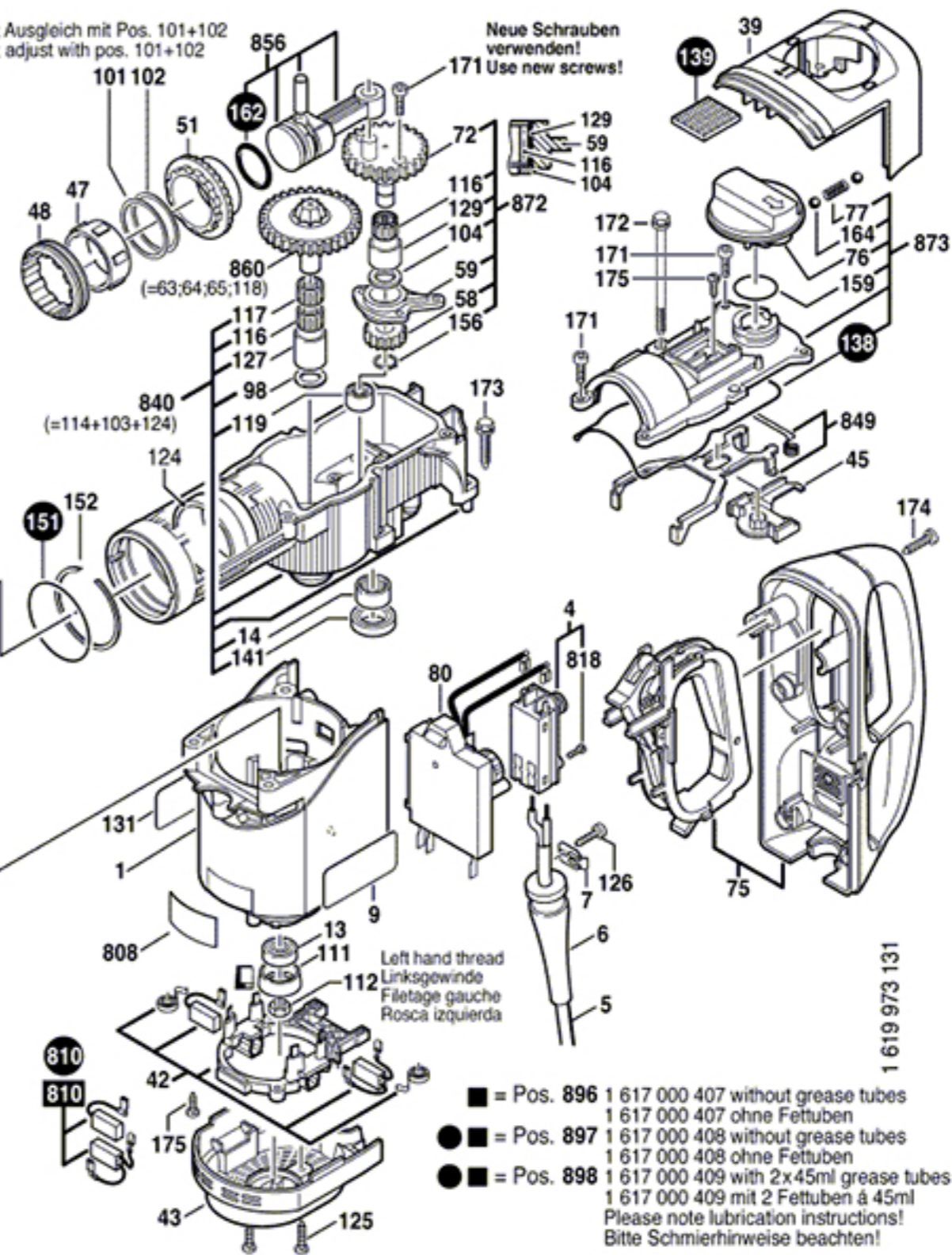
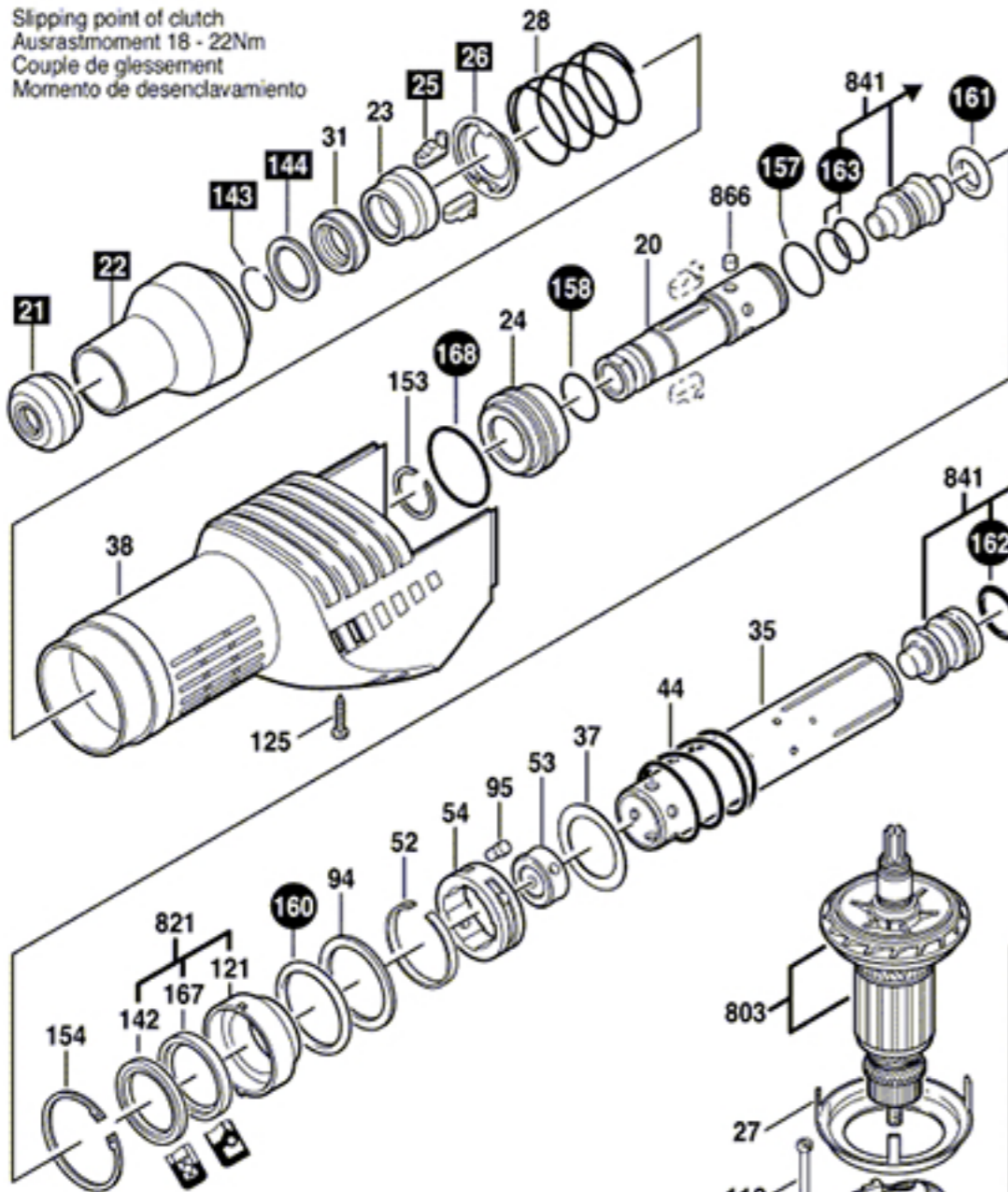

Modifications reserved
Änderungen vorbehalten
Modifications réservées
Salvo modificaciones

■ = Pos. 896 1 617 000 407 without grease tubes
1 617 000 407 ohne Fettuben
● = Pos. 897 1 617 000 408 without grease tubes
1 617 000 408 ohne Fettuben
● = Pos. 898 1 617 000 409 with 2x45ml grease tubes
1 617 000 409 mit 2 Fettuben à 45ml
Please note lubrication instructions!
Bitte Schmierhinweise beachten!

1 619 973 131

0 611 235 839

Issue }
Stand } 05-02-14

Fig./Abb. 2

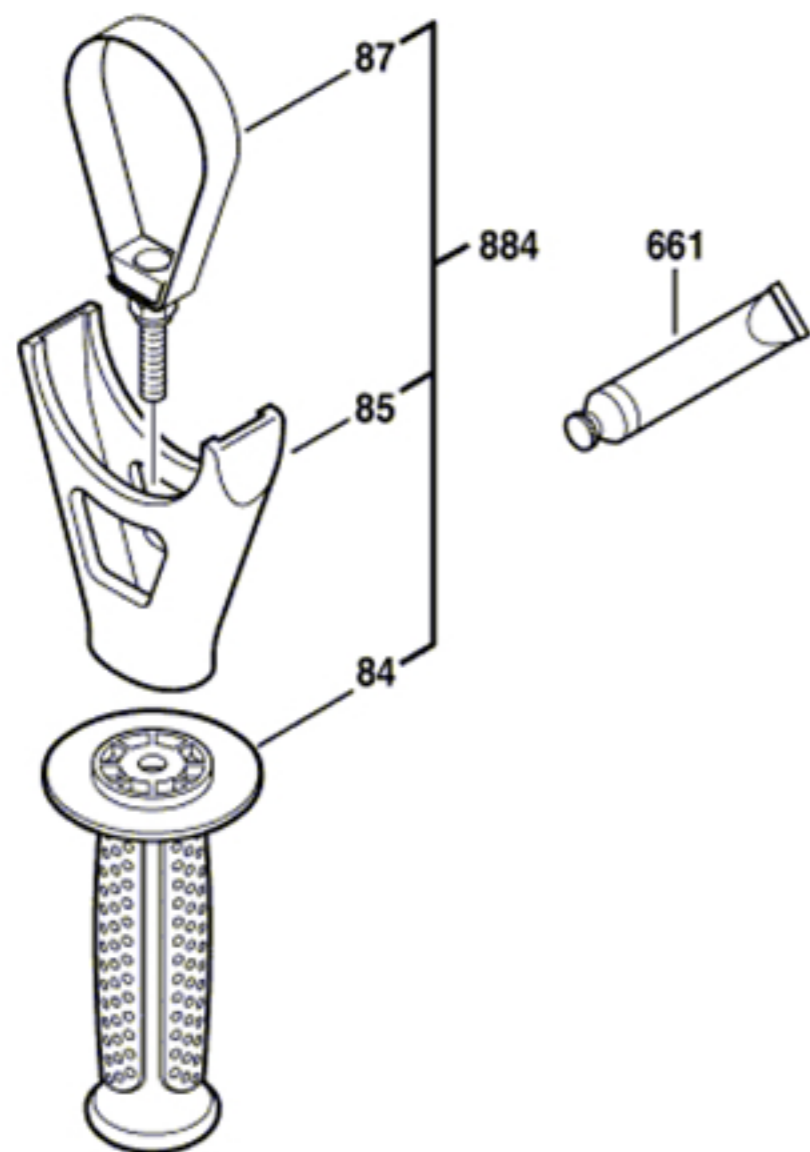

Neue Ausführung
New execution
Nouvelle exécution
Nueva ejecución

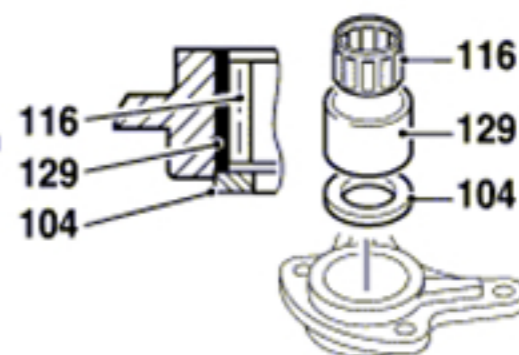

Alte Ausführung
Old execution
Ancien exécution
Vieja ejecución

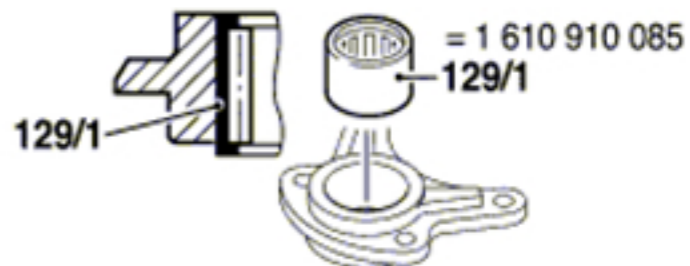

Modifications reserved
Änderungen vorbehalten
Modifications réservées
Salvo modificaciones