

Husqvarna®



1330SB-XLSb

Illustrated Parts List / 96193004100 / 2009-02

REPAIR PARTS

AUGER HOUSING / IMPELLER ASSEMBLY

SNOWTHROWER - MODEL NO. 1330SB-XLSB (96193004100), PRODUCT NO. 961 9300-41

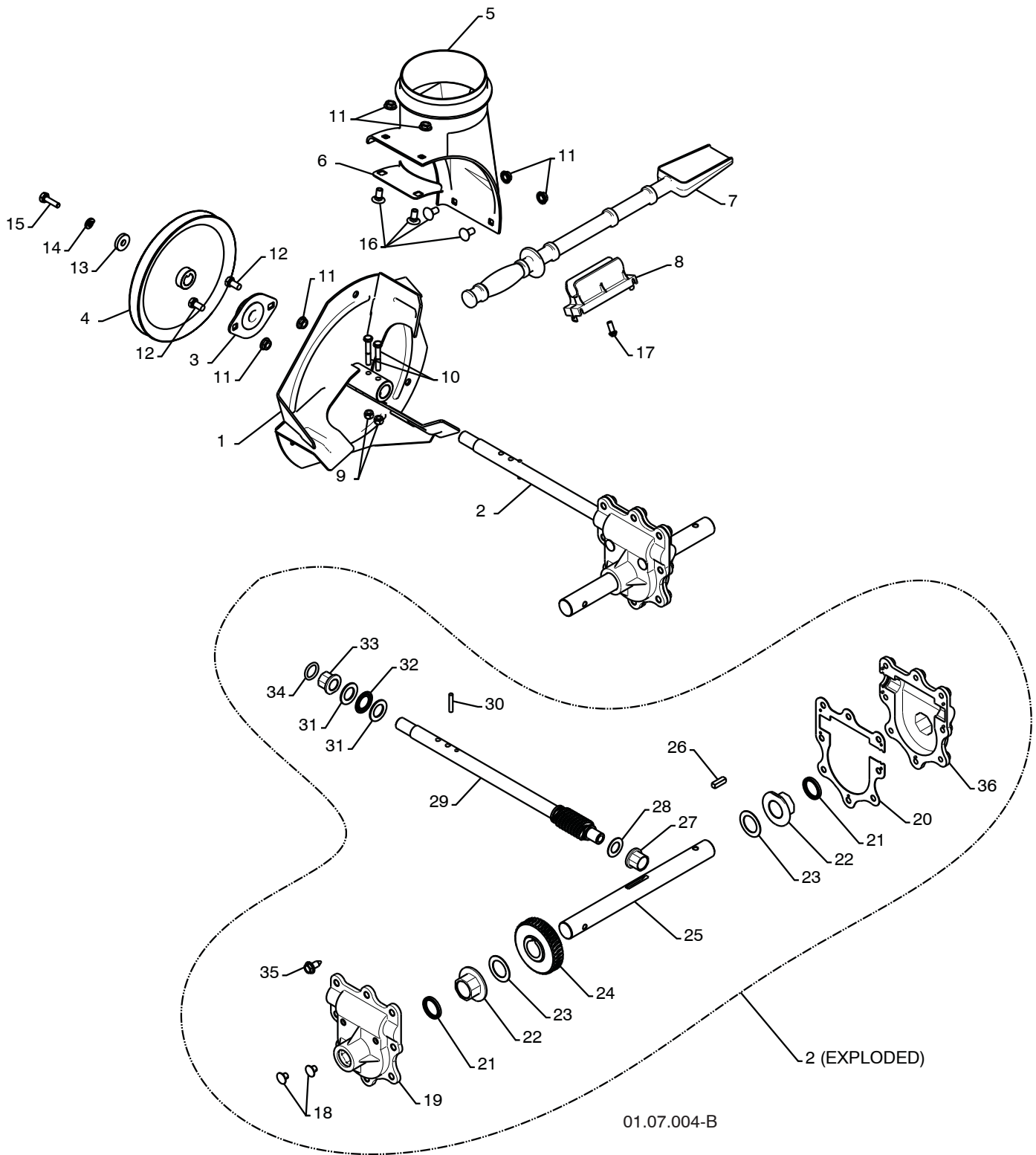

REPAIR PARTS

AUGER HOUSING / IMPELLER ASSEMBLY

SNOWTHROWER - MODEL NO. **1330SB-XLSB** (96193004100), PRODUCT NO. 961 93 00-41

KEY NO.	PART NO.	DESCRIPTION
1	532 18 41-05	IMPELLER
2	532 19 67-10	GEARBOX ASSEMBLY
3	532 18 89-09	BEARING
4	532 19 10-79	IMPELLER PULLEY
5	532 17 53-22	DISCHARGE BASE
6	532 18 40-95	CORNER BRACKET
7	532 19 21-99	CLEAN OUT TOOL
8	532 40 54-00	TOOL CLIP
9	873 80 04-00	NUT 1/4-20
10	874 78 04-26	SCREW 1/4-20 X .625
11	532 15 53-77	NUT 5/16-18
12	532 16 31-83	SCREW 5/16-18 X .625
13	819 11 15-07	WASHER
14	810 04 05-00	LOCKWASHER 5/16
15	874 94 05-16	SCREW 5/16-18 X 1.00
16	532 18 03-55	CARRIAGE BOLT
17	532 19 41-89	SCREW 13-16 X .625
18	532 40 77-60	PLUG
19	532 40 77-61	GEARBOX COVER RH
20	532 40 77-66	GASKET
21	532 40 77-70	SEAL
22	532 40 77-62	BEARING
23	532 17 46-97	THRUST WASHER 1.00
24	532 40 77-63	WORM GEAR
25	532 40 77-64	AUGER SHAFT
26	532 18 92-82	SQUARE KEY
27	532 40 77-58	BEARING
28	532 17 46-83	THRUST WASHER
29	532 40 77-57	IMPELLER SHAFT
30	532 18 42-05	ROLL PIN
31	532 17 46-81	THRUST WASHER
32	532 17 46-84	THRUST BEARING
33	532 40 77-69	BEARING
34	532 40 77-68	O-RING
35	532 40 77-67	SCREW 5/16-18 X .750
36	532 40 77-65	GEARBOX COVER LH

NOTE: All component dimensions given in U.S. inches. 1 inch = 25.4 mm

IMPORTANT: Use only Original Equipment Manufacturer (O.E.M.) replacement parts. Failure to do so could be hazardous, damage your snow thrower and void your warranty.

REPAIR PARTS

AUGER HOUSING / IMPELLER ASSEMBLY

SNOWTHROWER - MODEL NO. 1330SB-XLSB (96193004100), PRODUCT NO. 961 9300-41

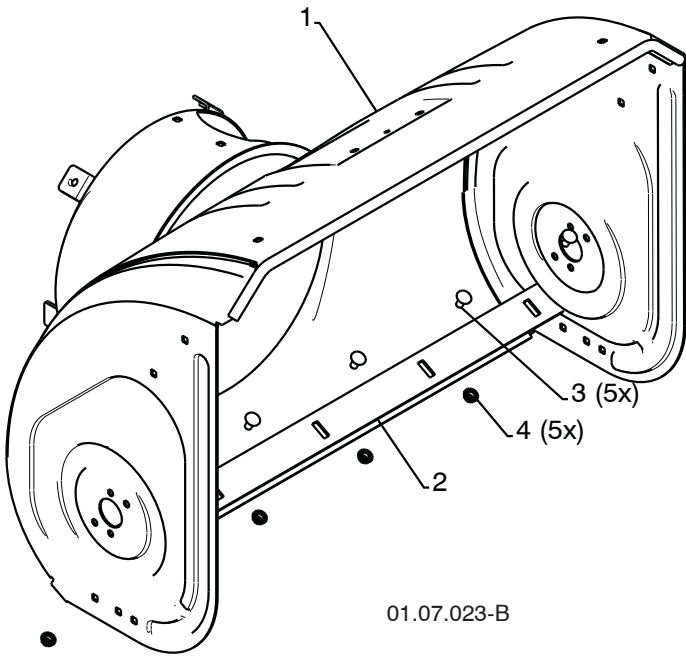

01.07.023-B

KEY NO.	PART NO.	DESCRIPTION
1	532 42 17-13	AUGER HOUSING
2	532 40 76-45	SCRAPPER BAR
3	872 27 05-05	CARRIAGE BOLT 5/16-18 X .625
4	532 15 53-77	NUT 5/16-18

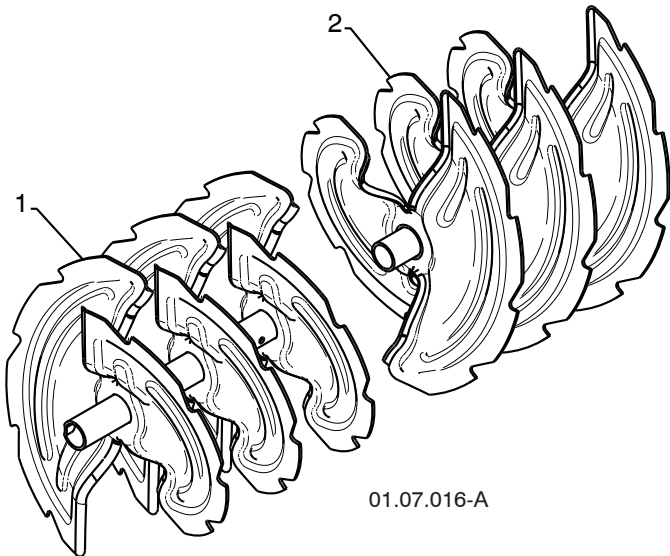

01.07.016-A

KEY NO.	PART NO.	DESCRIPTION
1	532 42 17-26	AUGER ASSEMBLY 30 LH
2	532 42 17-27	AUGER ASSEMBLY 30 RH

NOTE: All component dimensions given in U.S. inches. 1 inch = 25.4 mm
IMPORTANT: Use only Original Equipment Manufacturer (O.E.M.) replacement parts.
 Failure to do so could be hazardous, damage your snow thrower and void your warranty.

REPAIR PARTS

AUGER HOUSING / IMPELLER ASSEMBLY

SNOWTHROWER - MODEL NO. 1330SB-XLSB (96193004100), PRODUCT NO. 961 93 00-41

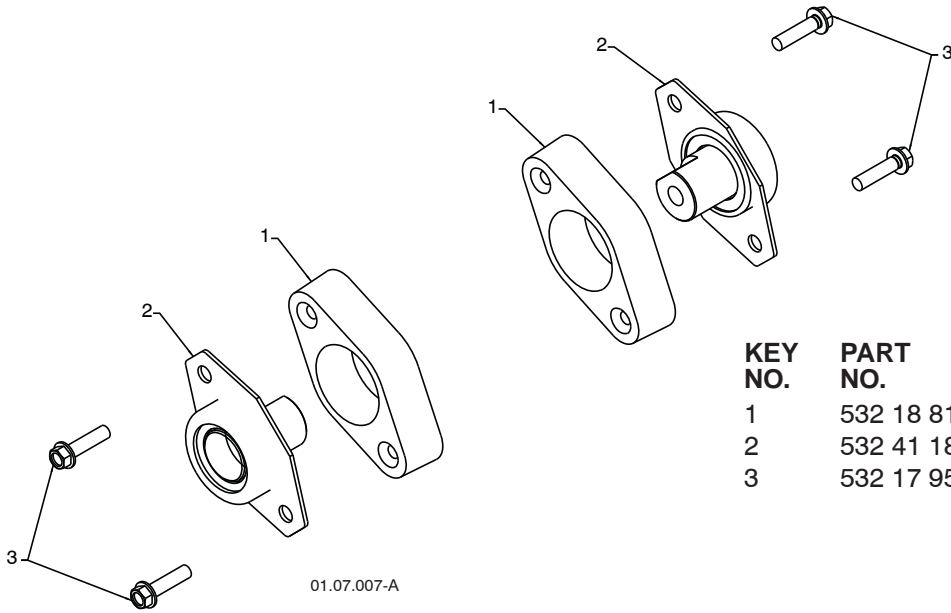

KEY NO.	PART NO.	DESCRIPTION
1	532 18 81-70	PLASTIC RETAINER
2	532 41 18-33	AUGER BALL BEARING
3	532 17 95-82	SCREW 5/16-18 X 1.00

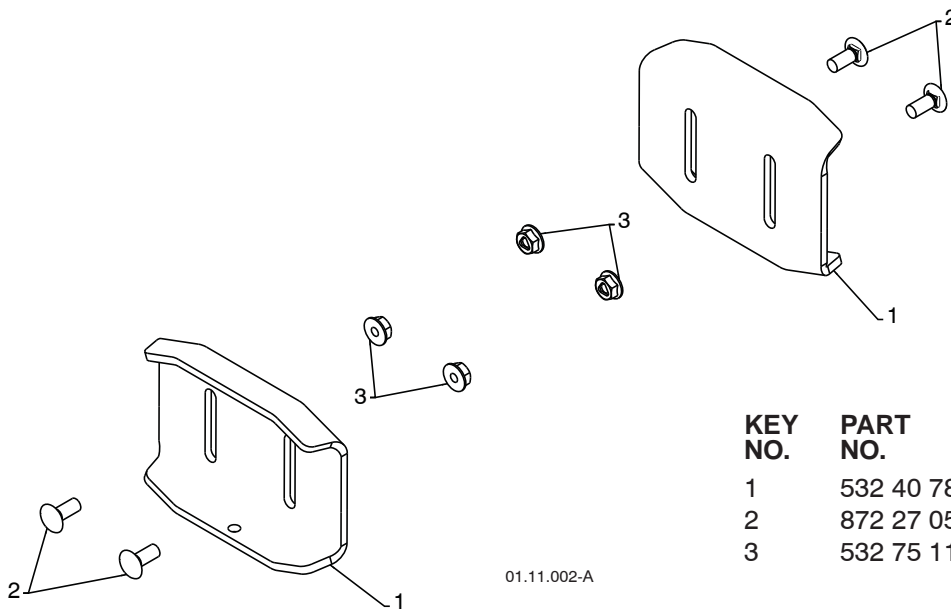

KEY NO.	PART NO.	DESCRIPTION
1	532 40 78-34	SKID PLATE
2	872 27 05-06	CARRIAGE BOLT 5/16-18 X .750
3	532 75 11-53	NUT 5/16-18

NOTE: All component dimensions given in U.S. inches. 1 inch = 25.4 mm
IMPORTANT: Use only Original Equipment Manufacturer (O.E.M.) replacement parts.
 Failure to do so could be hazardous, damage your snow thrower and void your warranty.

REPAIR PARTS

AUGER HOUSING / IMPELLER ASSEMBLY

SNOWTHROWER - MODEL NO. 1330SB-XLSB (96193004100), PRODUCT NO. 961 9300-41

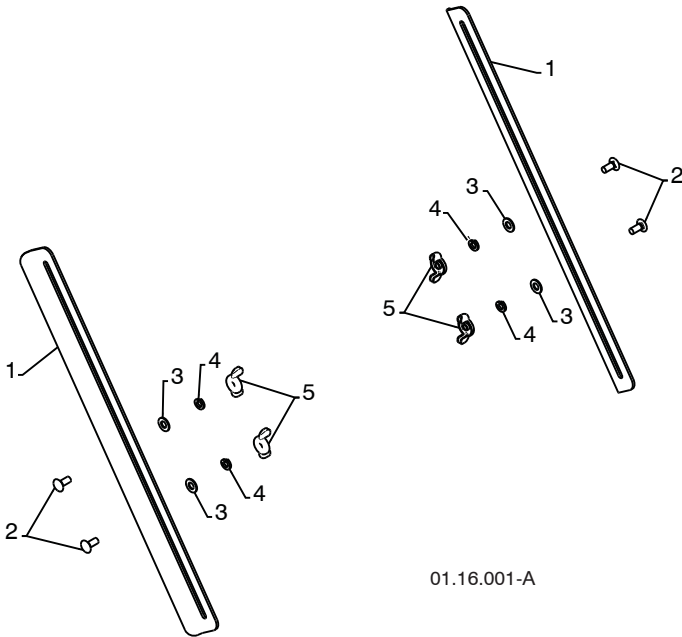

01.16.001-A

KEY NO.	PART NO.	DESCRIPTION
1	532 18 47-47	DRIFT CUTTER BAR
2	872 27 05-06	CARRIAGE BOLT 5/16-18X.750
3	532 17 92-46	PLASTIC WASHER
4	810 04 05-00	LOCKWASHER 5/16
5	532 12 86-38	NUT 5/16-18

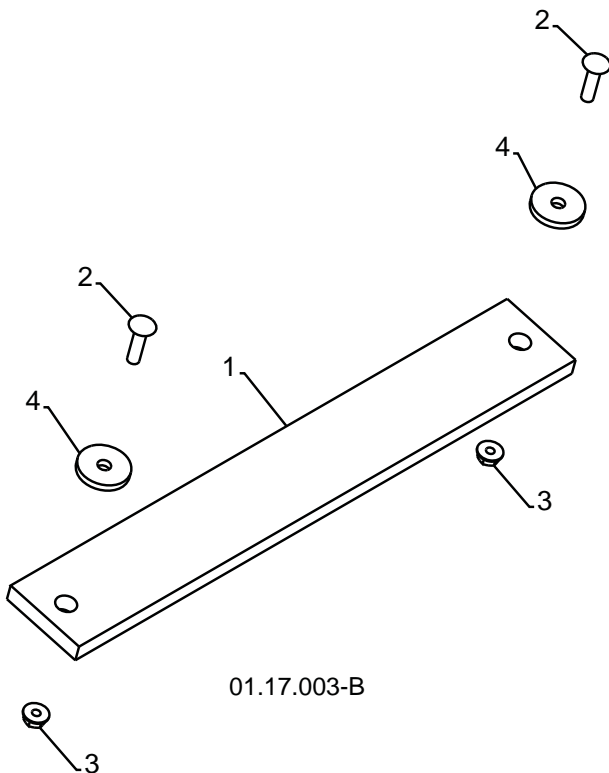

01.17.003-B

KEY NO.	PART NO.	DESCRIPTION
1	532 18 25-16	WEIGHT BAR
2	872 11 05-10	CARRIAGE BOLT 5/16-18 X 1.25
3	532 75 11-53	NUT 5/16-18
4	819 11 22-06	WASHER

NOTE: All component dimensions given in U.S. inches. 1 inch = 25.4 mm
IMPORTANT: Use only Original Equipment Manufacturer (O.E.M.) replacement parts.
 Failure to do so could be hazardous, damage your snow thrower and void your warranty.

REPAIR PARTS

CONTROL PANEL / DISCHARGE CHUTE

SNOWTHROWER - MODEL NO. 1330SB-XLSB (96193004100), PRODUCT NO. 961 9300-41

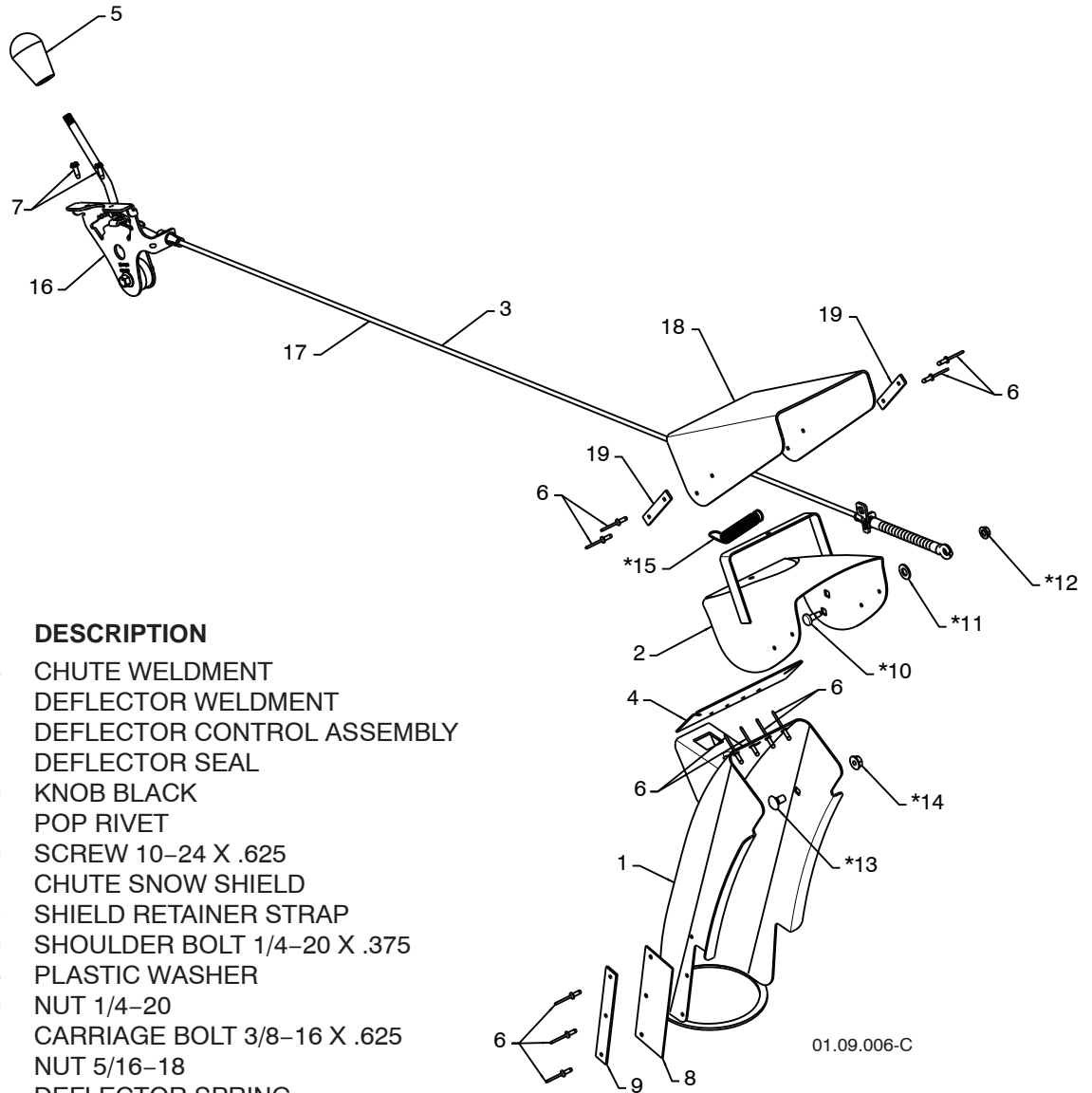

KEY NO.	PART NO.	DESCRIPTION
1	532 42 17-14	CHUTE WELDMENT
2	532 18 41-13	DEFLECTOR WELDMENT
3	532 42 11-63	DEFLECTOR CONTROL ASSEMBLY
4	532 42 03-25	DEFLECTOR SEAL
5	532 41 42-80	KNOB BLACK
6	532 12 84-15	POP RIVET
7	817 50 10-10	SCREW 10-24 X .625
8	532 41 98-21	CHUTE SNOW SHIELD
9	532 42 17-28	SHIELD RETAINER STRAP
*10	532 17 98-29	SHOULDER BOLT 1/4-20 X .375
*11	532 17 92-46	PLASTIC WASHER
*12	532 19 17-30	NUT 1/4-20
*13	872 25 05-05	CARRIAGE BOLT 3/8-16 X .625
*14	532 75 11-53	NUT 5/16-18
*15	532 18 45-05	DEFLECTOR SPRING
16	532 42 06-79	(SERVICE PART) DEFLECTOR CONTROL
17	532 42 11-64	(SERVICE PART) DEFLECTOR CABLE GRAY
18	532 42 11-38	DEFLECTOR SHIELD
19	532 42 32-47	DEFLECTOR SHIELD STRAP

NOTES:

1. ITEMS INDICATED WITH AN * ARE LISTED AS REFERENCE FOR SERVICE PARTS ONLY.

NOTE: All component dimensions given in U.S. inches. 1 inch = 25.4 mm
IMPORTANT: Use only Original Equipment Manufacturer (O.E.M.) replacement parts. Failure to do so could be hazardous, damage your snow thrower and void your warranty.

REPAIR PARTS

CONTROL PANEL / DISCHARGE CHUTE

SNOWTHROWER - MODEL NO. 1330SB-XLSB (96193004100), PRODUCT NO. 961 93 00-41

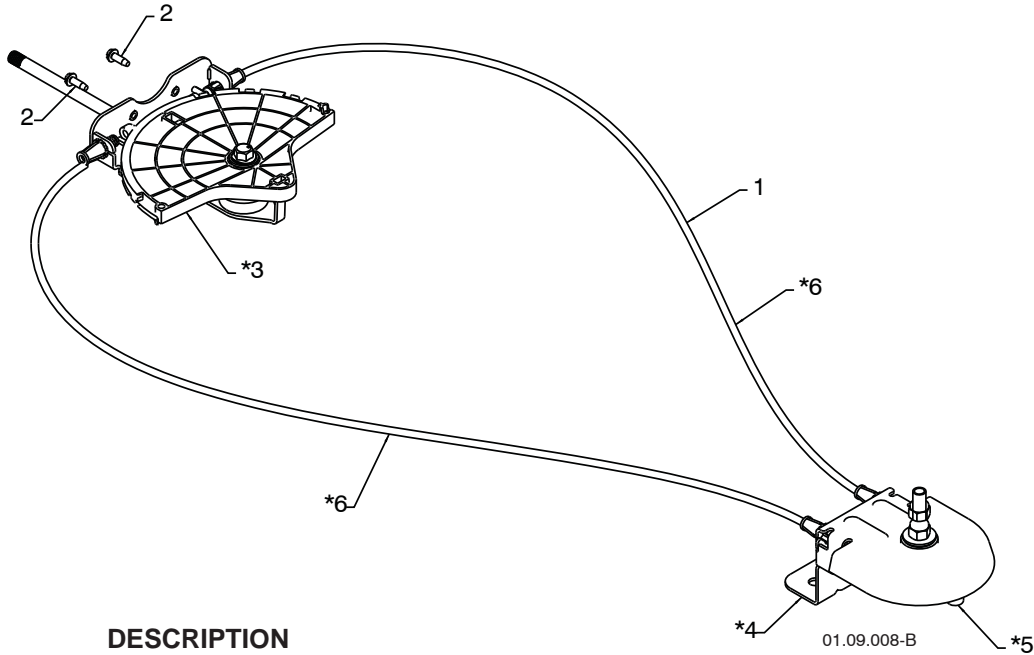

KEY NO.	PART NO.	DESCRIPTION
1	532 42 11-60	LEVER/CABLE ROTATOR ASSEMBLY GRAY
2	817 50 10-10	SCREW 10-24 X .625
*3	532 42 06-78	ROTATOR HEAD
*4	532 42 11-61	ROTATOR PIVOT BRACKET
*5	532 42 06-75	PULLEY PIVOT
*6	532 42 11-62	CABLE ASSEMBLY GRAY

NOTES:

1. ITEMS INDICATED WITH AN * ARE LISTED AS REFERENCE FOR SERVICE PARTS ONLY.

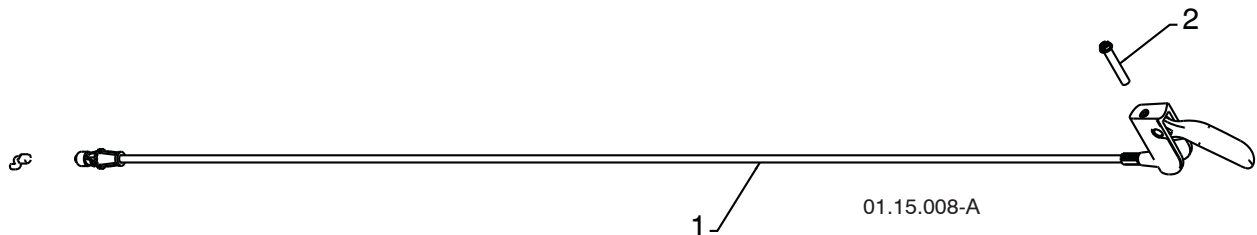

KEY NO.	PART NO.	DESCRIPTION
1	532 42 12-31	STEER CABLE
2	874 04 10-24	SCREW 10-24 X 1.50

NOTE: All component dimensions given in U.S. inches. 1 inch = 25.4 mm
IMPORTANT: Use only Original Equipment Manufacturer (O.E.M.) replacement parts. Failure to do so could be hazardous, damage your snow thrower and void your warranty.

REPAIR PARTS

HANDLES

SNOWTHROWER - MODEL NO. 1330SB-XLSB (96193004100), PRODUCT NO. 961 9300-41

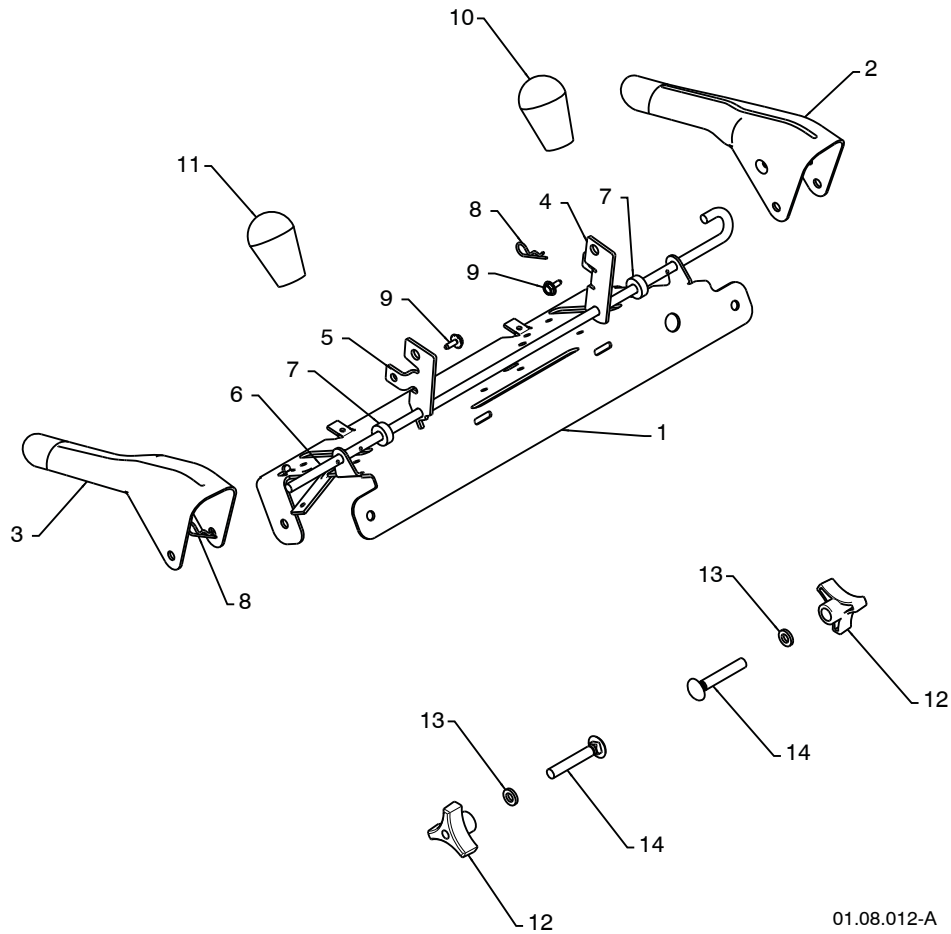

01.08.012-A

KEY NO.	PART NO.	DESCRIPTION
1	532 41 55-39	CONTROL PANEL
2	532 42 17-06	CONTROL LEVER LH
3	532 42 17-07	CONTROL LEVER RH
4	532 41 55-46	TRACTION ROD ARM
5	532 42 14-92	IMPELLER ROD ARM
6	532 41 26-77	INTERLOCK ROD
7	532 41 26-80	SPACER
8	532 16 96-75	RETAINER
9	817 06 04-08	SCREW 1/4-20 X .50
10	532 41 42-80	KNOB BLACK
11	532 41 42-81	KNOB RED
12	532 17 88-99	HANDLE KNOB
13	819 13 13-16	WASHER 3/8
14	872 12 06-18	CARRIAGE BOLT 3/8-16 X 2.25

NOTE: All component dimensions given in U.S. inches. 1 inch = 25.4 mm
IMPORTANT: Use only Original Equipment Manufacturer (O.E.M.) replacement parts.
 Failure to do so could be hazardous, damage your snow thrower and void your warranty.

REPAIR PARTS

HANDLES

SNOWTHROWER - MODEL NO. **1330SB-XLSB** (96193004100), PRODUCT NO. 961 9300-41

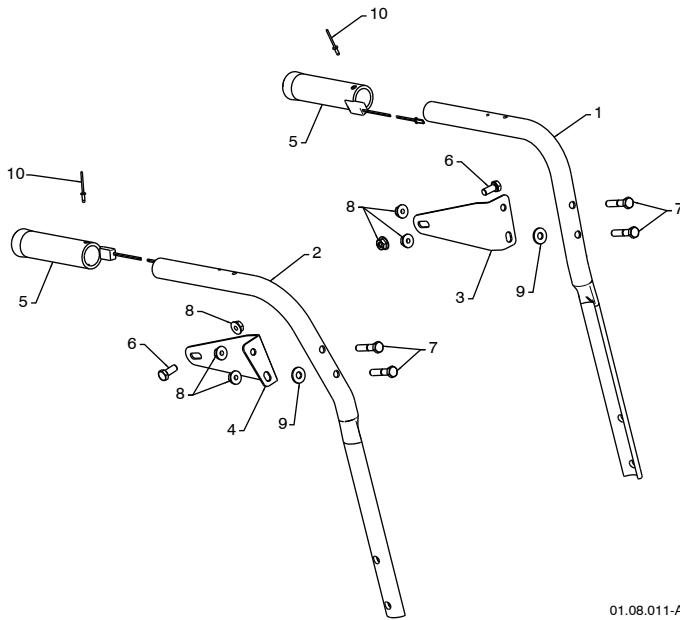

KEY NO.	PART NO.	DESCRIPTION
1	532 42 17-08	PLOW HANDLE LH
2	532 42 17-09	PLOW HANDLE RH
3	532 19 69-44	PANEL BRACKET LH
4	532 19 69-43	PANEL BRACKET RH
5	532 41 45-15	HEATED HANDLE GRIP
6	874 78 05-12	SCREW 5/16-18 X .750
7	874 78 05-24	SCREW 5/16-18 X 1.50
8	532 75 11-53	NUT 5/16-18
9	532 15 54-15	WASHER
10	532 17 87-75	POP RIVET 1/8

01.08.011-A

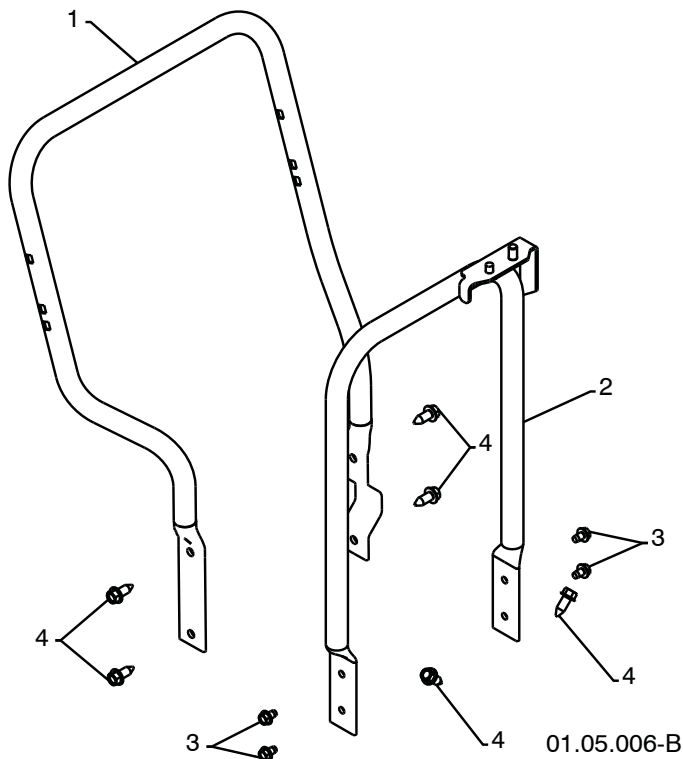

KEY NO.	PART NO.	DESCRIPTION
1	532 42 17-05	LOWER TUBE GRAY
2	532 40 76-43	PIVOT SUPPORT
3	532 15 00-78	BOLT 5/16-18 X .750
4	817 00 06-16	SCREW 3/8-16 X 1.00

01.05.006-B

NOTE: All component dimensions given in U.S. inches. 1 inch = 25.4 mm
IMPORTANT: Use only Original Equipment Manufacturer (O.E.M.) replacement parts.
 Failure to do so could be hazardous, damage your snow thrower and void your warranty.

REPAIR PARTS

HANDLES

SNOWTHROWER - MODEL NO. 1330SB-XLSB (96193004100), PRODUCT NO. 961 9300-41

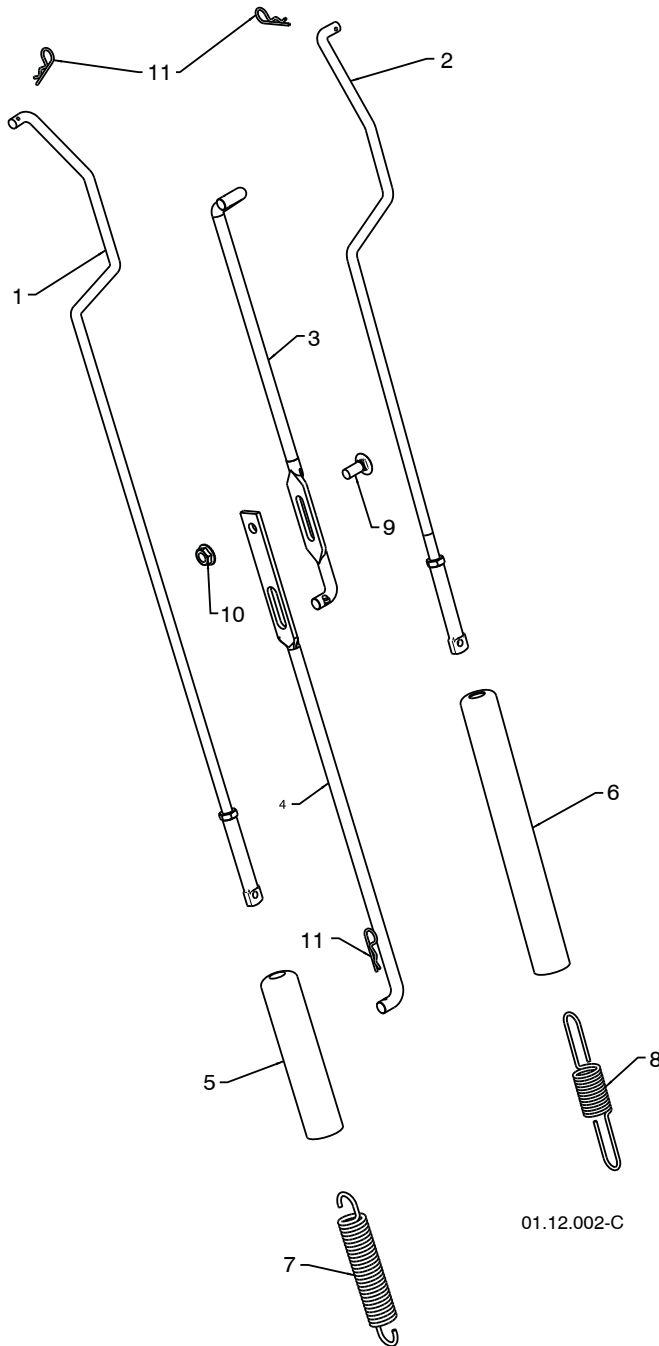

KEY NO.	PART NO.	DESCRIPTION
1	532 42 17-63	IMPELLER ROD ASSEMBLY
2	532 18 04-85	TRACTION ROD ASSEMBLY
3	532 18 77-82	SHIFTER ROD TOP
4	532 18 77-84	SHIFTER ROD BOTTOM
5	532 18 04-47	SPRING SLEEVE
6	532 19 20-91	SPRING SLEEVE
7	532 17 86-69	IMPELLER SPRING
8	532 18 09-26	TRACTION SPRING
9	872 27 05-06	CARRIAGE BOLT 5/16-18 X .750
10	532 15 53-77	NUT 5/16-18
11	532 16 96-75	RETAINER

NOTE: All component dimensions given in U.S. inches. 1 inch = 25.4 mm
IMPORTANT: Use only Original Equipment Manufacturer (O.E.M.) replacement parts.
 Failure to do so could be hazardous, damage your snow thrower and void your warranty.

REPAIR PARTS

HANDLES

SNOWTHROWER - MODEL NO. 1330SB-XLSB (96193004100), PRODUCT NO. 961 9300-41

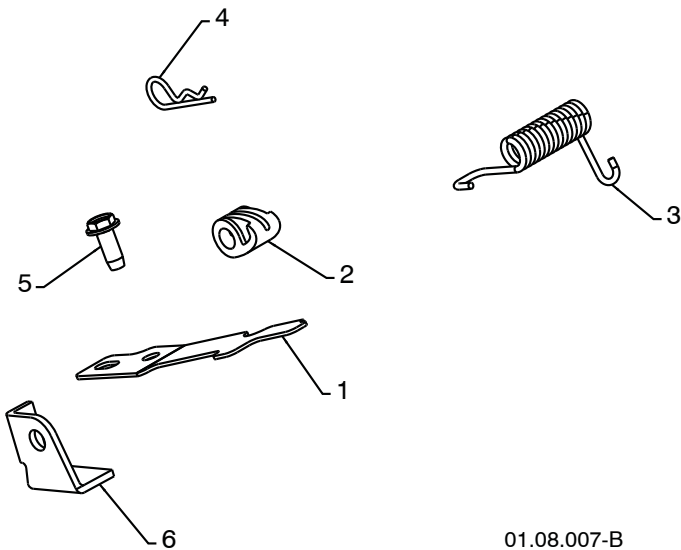

KEY NO.	PART NO.	DESCRIPTION
1	532 41 62-88	INTERLOCK SPRING
2	532 41 45-72	INTERLOCK CAM
3	532 17 88-31	TORSION SPRING
4	532 16 96-75	RETAINER
5	817 06 04-10	SCREW 1/4-20 X .625
6	532 42 18-14	INTERLOCK STOP

01.08.007-B

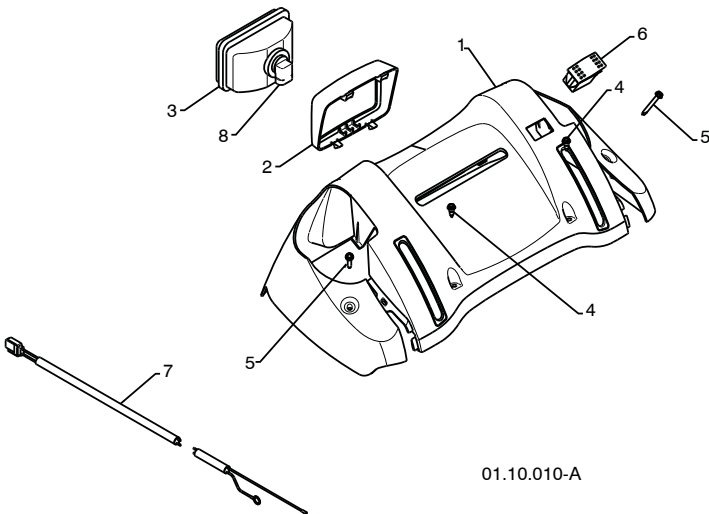

KEY NO.	PART NO.	DESCRIPTION
1	532 42 13-51	CONSOLE PANEL GRAY
2	532 42 14-48	HEADLIGHT BEZEL GRAY
3	532 17 86-66	HALOGEN HEADLIGHT
4	532 18 44-71	SHOULDER SCREW 10-24 X .625
5	532 17 52-62	SCREW 10-24 X 1.25
6	532 41 77-60	GRIP SWITCH
7	532 40 56-99	WIRE HARNESS
8	532 40 16-20	BULB

01.10.010-A

NOTE: All component dimensions given in U.S. inches. 1 inch = 25.4 mm
IMPORTANT: Use only Original Equipment Manufacturer (O.E.M.) replacement parts.
 Failure to do so could be hazardous, damage your snow thrower and void your warranty.

REPAIR PARTS

DRIVE

SNOWTHROWER - MODEL NO. 1330SB-XLSB (96193004100), PRODUCT NO. 961 93 00-41

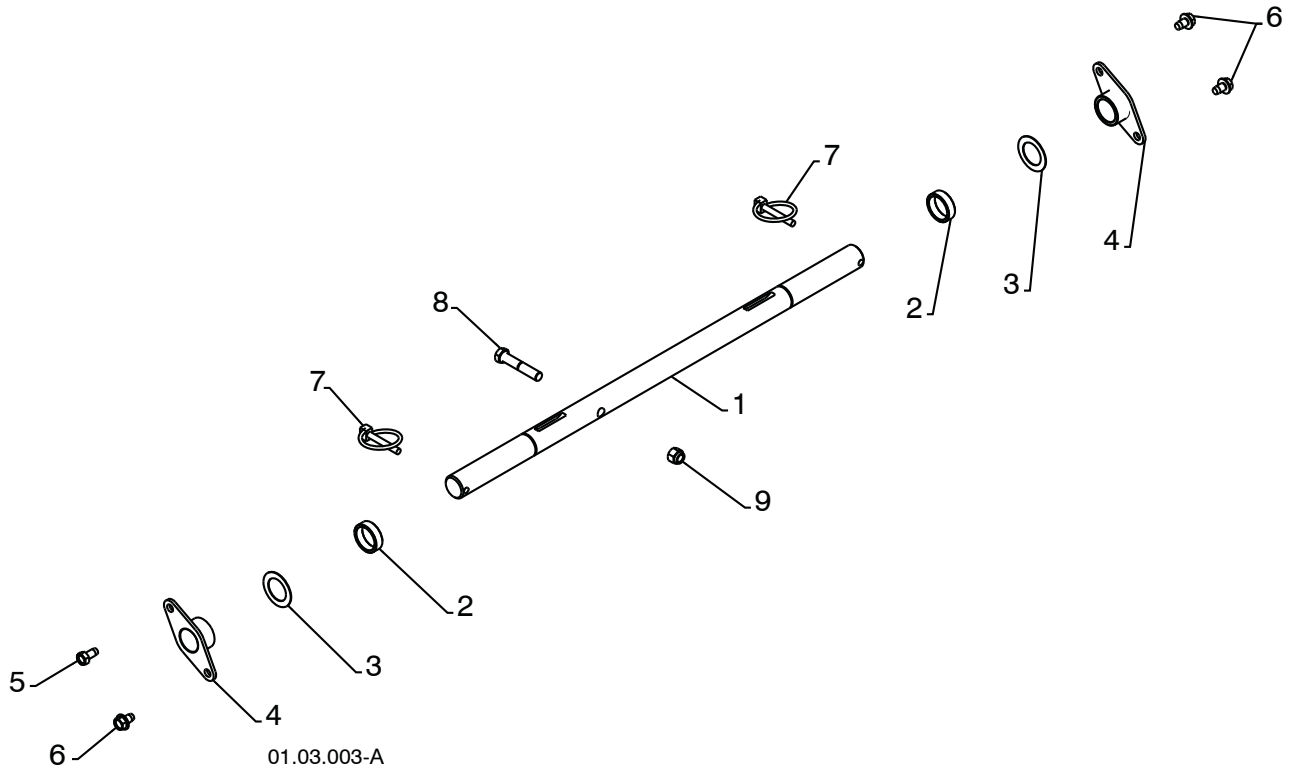

KEY NO.	PART NO.	DESCRIPTION
1	532 40 43-08	AXLE SHAFT
2	532 18 77-94	SPACER
3	532 17 46-97	THRUST WASHER
4	532 17 98-30	BEARING
5	532 14 63-15	SCREW 5/16-18 X .625
6	817 49 05-08	BOLT 5/16-18 X .500
7	532 15 54-43	CLIK PIN
8	874 78 06-32	SCREW 3/8-16 X 2.00
9	873 80 06-00	NUT 3/8-16

NOTE: All component dimensions given in U.S. inches. 1 inch = 25.4 mm
IMPORTANT: Use only Original Equipment Manufacturer (O.E.M.) replacement parts.
Failure to do so could be hazardous, damage your snow thrower and void your warranty.

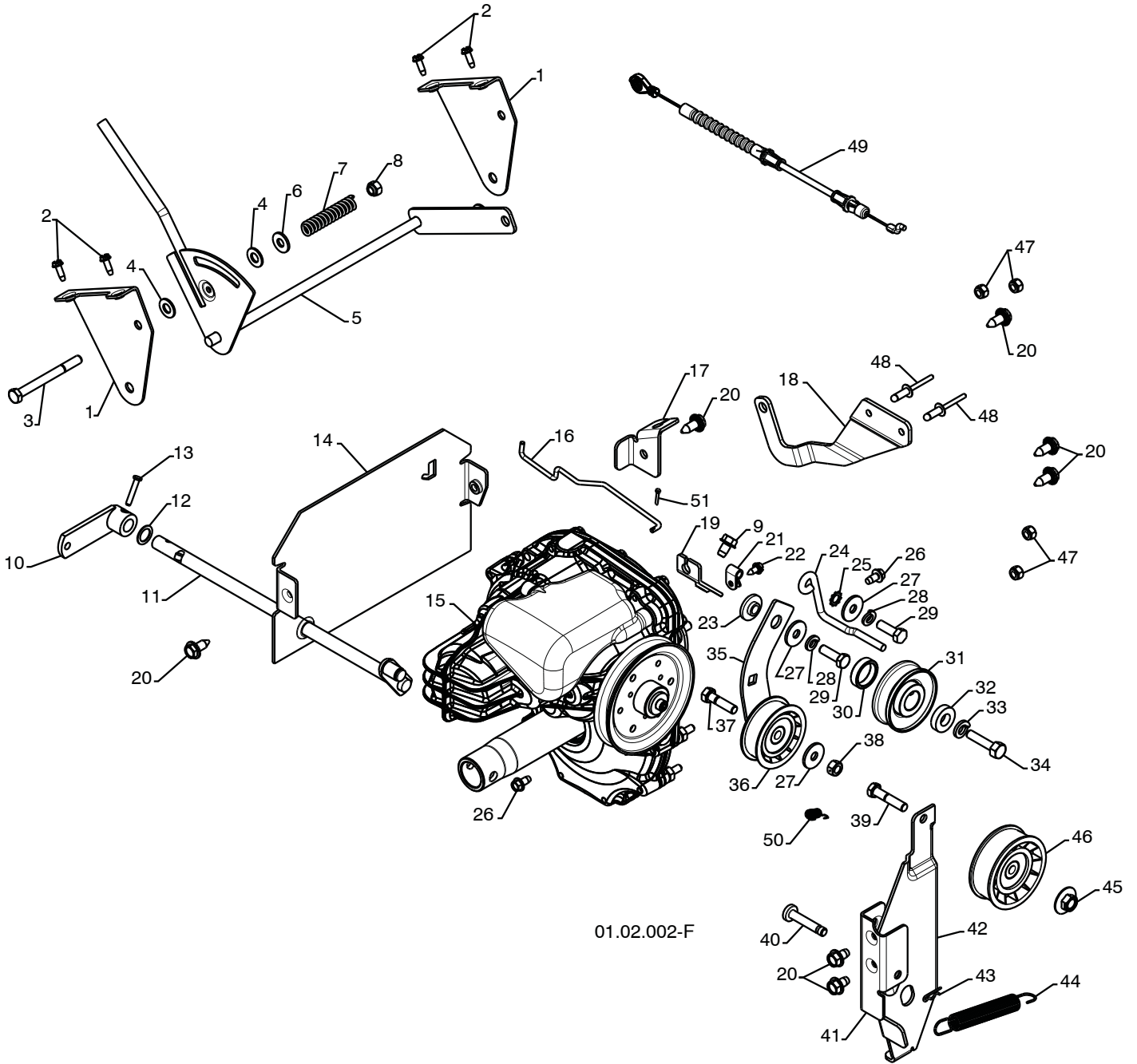

01.02.002-F

REPAIR PARTS**DRIVE****SNOW THROWER - MODEL NO. 1330SB-XLSB (96193004100), PRODUCT NO. 961 93 00-41**

KEY NO.	PART NO.	DESCRIPTION	KEY NO.	PART NO.	DESCRIPTION
1	532 19 20-02	SHIFT BRACKET	27	532 05 92-89	WASHER
2	817 50 10-10	SCREW 10-24 X .625	28	810 04 05-00	LOCKWASHER 5/16
3	874 76 05-52	SCREW 5/16-18 X 3.25	29	874 61 05-16	SCREW 5/16-18 X 1.00
4	532 17 92-46	PLASTIC WASHER	30	532 40 94-75	SPACER
5	532 19 20-01	SHIFT ASSEMBLY	31	532 18 04-78	ENGINE TRACTION PULLEY
6	532 15 54-15	WASHER	32	532 40 00-26	WASHER
7	532 19 21-95	FRICTION SPRING	33	532 85 02-63	LOCKWASHER 3/8
8	873 80 05-00	NUT 5/16-18	34	532 85 10-84	SCREW 3/8-24 X 1.38
9	817 49 05-08	BOLT 5/16-18 X .500	35	532 18 77-86	TRACTION IDLER ARM
10	532 40 54-84	CONTROL ARM	36	532 18 05-22	IDLER PULLEY
11	532 40 61-09	CONTROL SHAFT	37	874 78 05-20	SCREW 5/16-18 X 1.25
12	532 05 70-79	WASHER	38	873 93 05-00	NUT 5/16-18
13	532 19 85-80	CLEVIS PIN	39	874 78 05-24	SCREW 5/16-18 X 1.50
14	532 19 21-15	REAR PLATE	40	532 17 53-30	PIN
15	532 18 77-76	TRANSMISSION	41	532 19 33-97	IDLER PIVOT BRACKET
16	532 19 32-56	ROD	42	532 41 99-25	IDLER BRAKE ARM
17	532 19 20-00	REAR CABLE BRACKET	43	532 08 51-79	RETAINER
18	532 18 77-87	CONTROL ARM	44	532 17 88-28	BRAKE SPRING
19	532 19 19-93	FRONT CABLE BRACKET	45	532 16 67-85	NUT 5/16-18
20	532 15 00-78	SCREW 5/16-18 X .750	46	532 18 05-23	PULLEY
21	532 08 79-30	CLIP	47	873 80 04-00	NUT 1/4-20
22	817 39 12-08	SCREW .12 X .50	48	532 19 19-95	POP RIVET 1/4 X .475
23	532 17 53-31	BUSHING	49	532 19 84-66	CLUTCH CABLE
24	532 19 36-07	BELT GUIDE	50	532 19 28-73	TRACTION SPRING
25	811 05 05-00	LOCKWASHER 5/16	51	532 70 02-79	RETAINER CLIP
26	817 49 04-08	SCREW 1/4-20 X .500			

NOTE: All component dimensions given in U.S. inches. 1 inch = 25.4 mm

IMPORTANT: Use only Original Equipment Manufacturer (O.E.M.) replacement parts. Failure to do so could be hazardous, damage your snow thrower and void your warranty.

REPAIR PARTS

DRIVE

SNOWTHROWER - MODEL NO. 1330SB-XLSB (96193004100), PRODUCT NO. 961 93 00-41

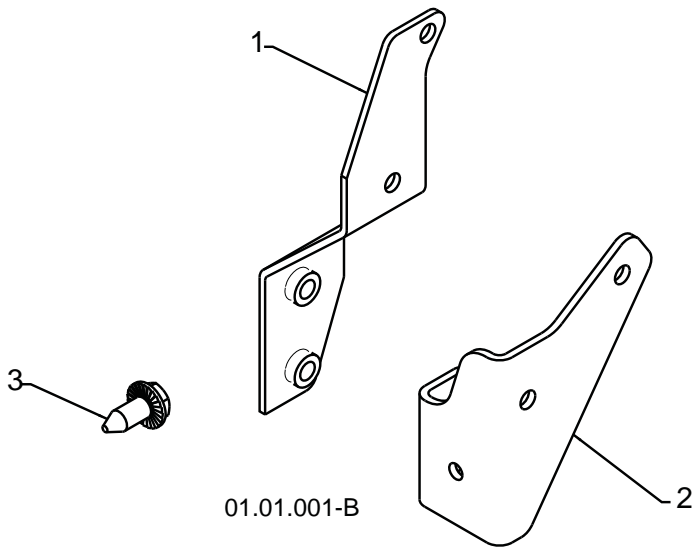

KEY NO.	PART NO.	DESCRIPTION
1	532 41 47-71	TORQUE STRAP
2	532 40 78-58	ANTI ROTATE BRACKET
3	532 15 00-78	SCREW 5/16-18 X .750

NOTE: All component dimensions given in U.S. inches. 1 inch = 25.4 mm
IMPORTANT: Use only Original Equipment Manufacturer (O.E.M.) replacement parts.
Failure to do so could be hazardous, damage your snow thrower and void your warranty.

REPAIR PARTS

CHASSIS / ENGINE / PULLEYS

SNOW THROWER - MODEL NO. 1330SB-XLSB (96193004100), PRODUCT NO. 961 9300-41

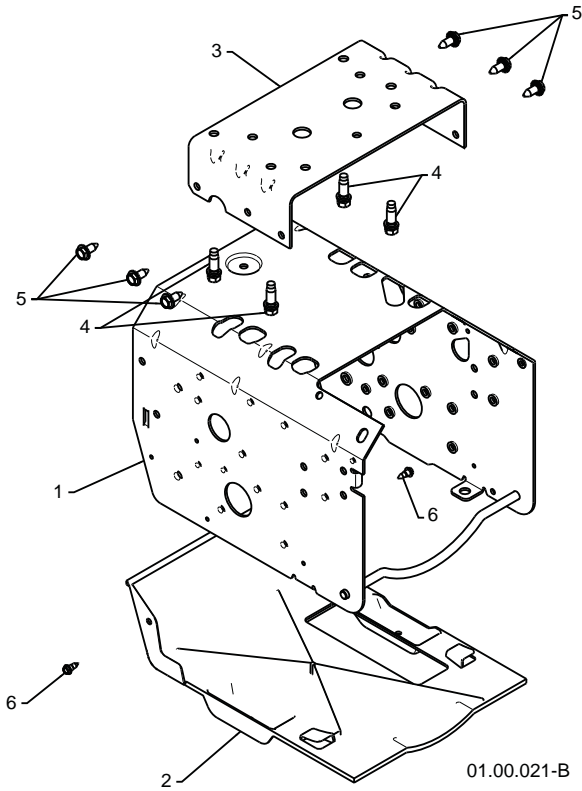

01.00.021-B

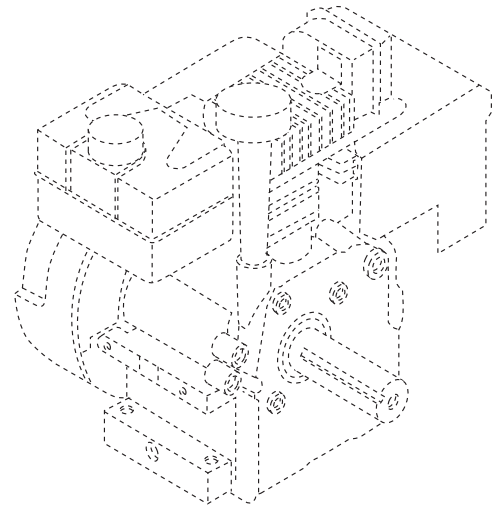

KEY NO.	PART NO.	DESCRIPTION
--	-----	B&S ENGINE MODEL 21M414-1182-E1
1	532 41 53-40	FRAME
2	532 40 37-32	BOTTOM PAN
3	532 42 38-70	ENGINE MOUNT PLATE
4	532 15 04-06	BOLT 3/8-16
5	532 15 00-78	SCREW 5/16-18 X .750
6	532 18 44-71	SCREW 10-24 X .625

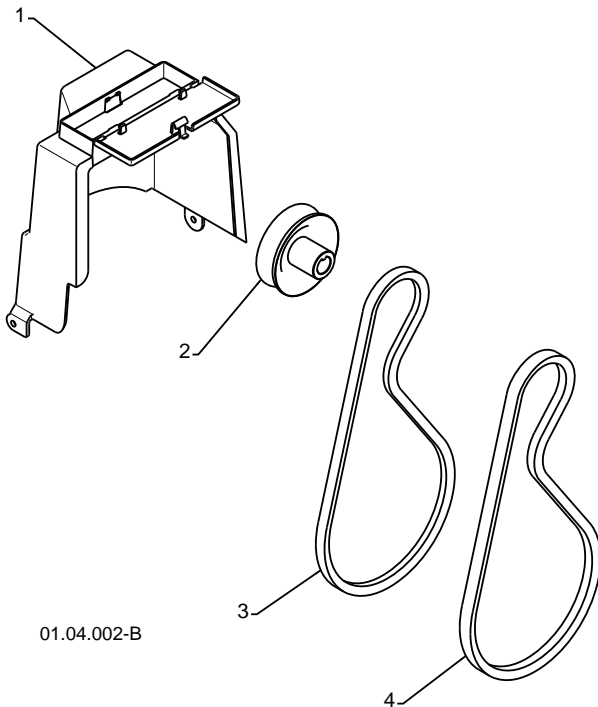

01.04.002-B

KEY NO.	PART NO.	DESCRIPTION
1	532 40 91-61	COVER ASSEMBLY
2	532 17 88-13	PULLEY
3	532 19 23-83	TRACTION BELT
4	532 40 80-19	IMPELLER BELT

NOTE: All component dimensions given in U.S. inches. 1 inch = 25.4 mm
IMPORTANT: Use only Original Equipment Manufacturer (O.E.M.) replacement parts. Failure to do so could be hazardous, damage your snow thrower and void your warranty.

REPAIR PARTS

WHEELS

SNOWTHROWER - MODEL NO. 1330SB-XLSB (96193004100), PRODUCT NO. 961 9300-41

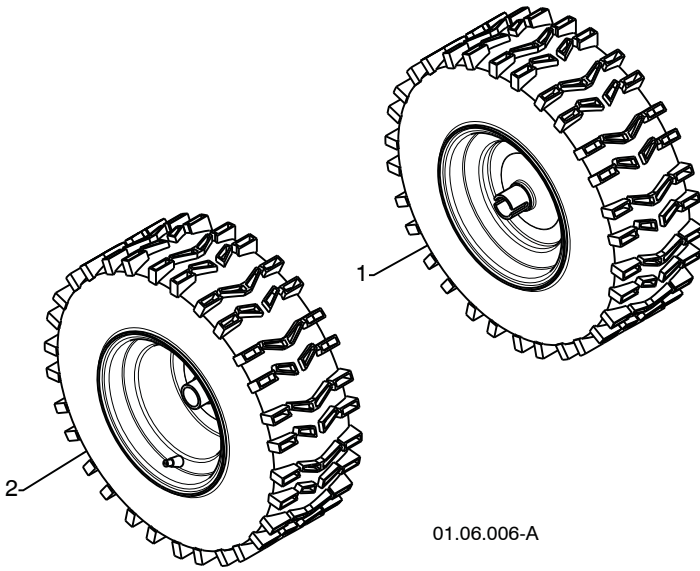

KEY NO.	PART NO.	DESCRIPTION
1	532 42 20-70	WHEEL ASSEMBLY LH
2	532 42 20-69	WHEEL ASSEMBLY RH

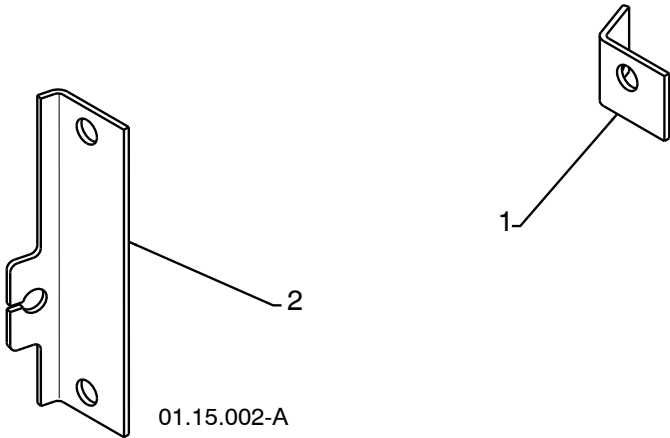

KEY NO.	PART NO.	DESCRIPTION
1	532 41 52-63	STEER CABLE BRACKET LH
2	532 18 78-59	STEER CABLE BRACKET RH

NOTE: All component dimensions given in U.S. inches. 1 inch = 25.4 mm
IMPORTANT: Use only Original Equipment Manufacturer (O.E.M.) replacement parts.
Failure to do so could be hazardous, damage your snow thrower and void your warranty.

REPAIR PARTS

WHEELS

SNOWTHROWER - MODEL NO. 1330SB-XLSB (96193004100), PRODUCT NO. 961 9300-41

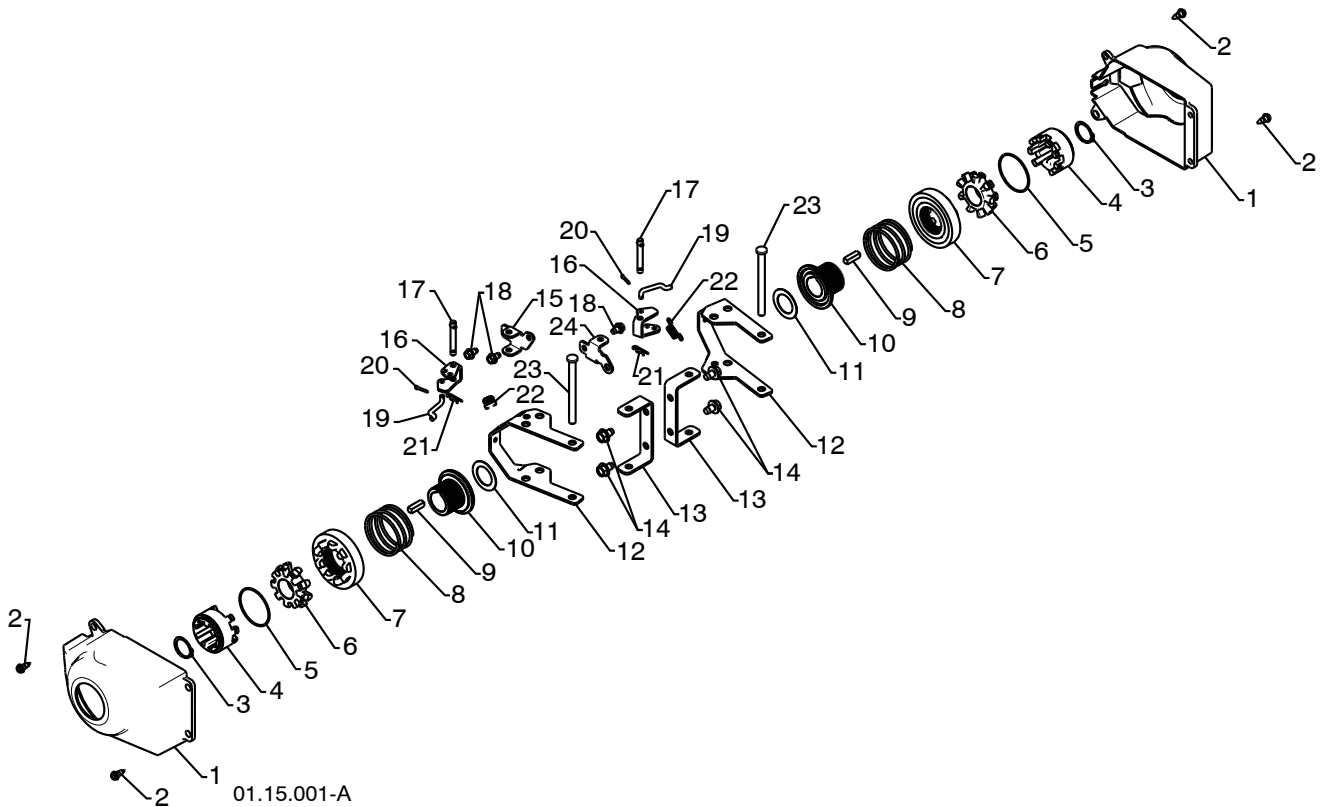

KEY NO.	PART NO.	DESCRIPTION
1	532 40 51-61	COVER
2	532 18 44-71	SHOULDER SCREW
3	812 00 00-45	RETAINER RING
4	532 19 21-26	WHEEL DRIVER
5	532 18 24-66	RETAINER RING
6	532 18 76-22	WHEEL LOBE
7	532 19 49-41	CLUTCH SLIDE
8	532 17 91-39	SPRING
9	532 18 92-82	SQUARE KEY
10	532 19 49-40	AXLE LOBE
11	532 17 46-97	THRUST WASHER
12	532 19 95-19	STEERING YOKE
13	532 18 41-97	STEERING BRACKET
14	817 49 05-08	SCREW 5/16-18 X .50
15	532 19 95-11	PIVOT BRACKET
16	532 19 95-18	BELLCRANK
17	532 18 18-47	BELLCRANK PIN
18	817 60 04-06	SCREW 1/4-20 X .375
19	532 40 50-77	STEERING LINK
20	532 70 02-79	RETAINER
21	532 08 51-79	RETAINER
22	532 19 38-85	SPRING
23	532 18 20-15	LEVER PIN
24	532 19 95-12	PIVOT BRACKET

NOTE: All component dimensions given in U.S. inches. 1 inch = 25.4 mm
IMPORTANT: Use only Original Equipment Manufacturer (O.E.M.) replacement parts.
 Failure to do so could be hazardous, damage your snow thrower and void your warranty.

REPAIR PARTS

BAG OF PARTS

SNOWTHROWER - MODEL NO. 1330SB-XLSB (96193004100), PRODUCT NO. 9619300-41

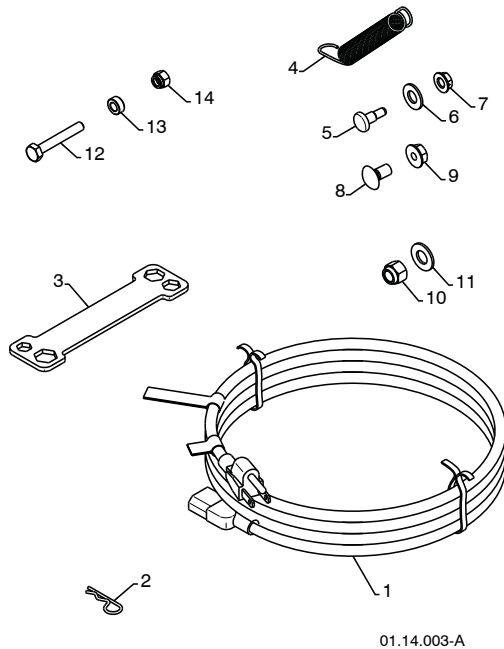

KEY NO.	PART NO.	DESCRIPTION
1	532 19 85-63	POWER CORD
2	532 16 96-75	RETAINER PIN
3	532 18 06-84	WRENCH
4	532 18 45-05	REMOTE SPRING
5	532 17 98-29	SHOULDER BOLT 1/4-20
6	532 17 92-46	NYLON WASHER 1/4-20
7	532 19 17-30	LOCKNUT 1/4-20
8	872 25 05-05	CARRIAGE BOLT 5/16-18 X 5/8
9	532 75 11-53	LOCKNUT 5/16-18
10	873 80 06-00	LOCKNUT 3/8-16
11	819 13 13-16	WASHER 3/8
12	532 19 86-36	SHEAR BOLT 1/4-20 X 1-3/4
13	532 19 86-38	SPACER
14	873 80 04-00	LOCKNUT 1/4-20



KEY NO.	PART NO.	DESCRIPTION
1	532 19 30-71	SAFETY IGNITION KEY

NOTE: All component dimensions given in U.S. inches. 1 inch = 25.4 mm
IMPORTANT: Use only Original Equipment Manufacturer (O.E.M.) replacement parts.
 Failure to do so could be hazardous, damage your snow thrower and void your warranty.

REPAIR PARTS

DECALS

SNOWTHROWER - MODEL NO. **1330SB-XLSB** (96193004100), PRODUCT NO. 961 9300-41

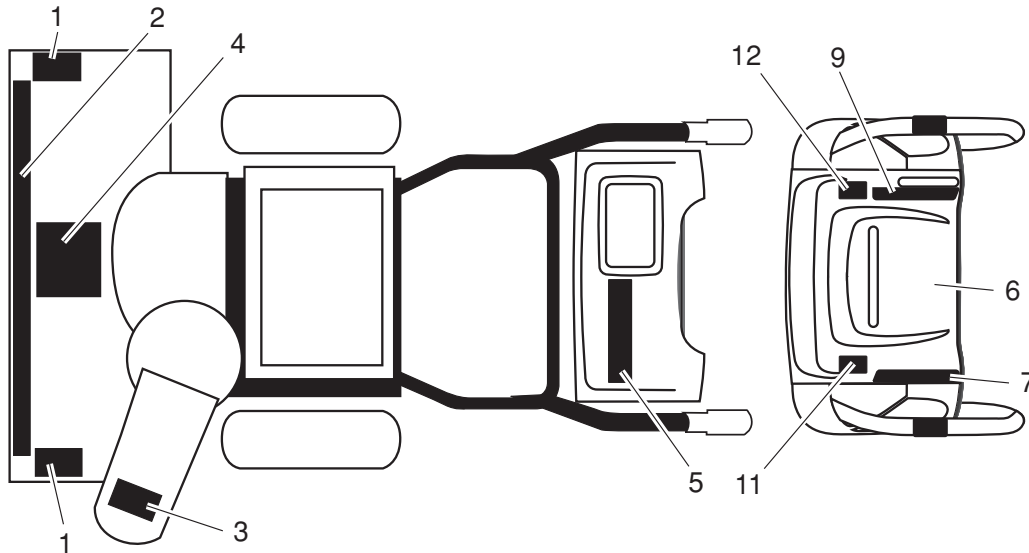

KEY NO.	PART NO.	DESCRIPTION
1	532 18 10-37	DECAL, DANGER
2	532 42 37-17	DECAL, HUSQVARNA 1330SB-XLSB
3	532 18 10-35	DECAL, DANGER, DEFLECTOR
4	532 18 10-42	DECAL, DANGER
5	532 42 37-16	DECAL, HUSQVARNA 1330SB-XLSB
6	532 18 10-33	DECAL, INSTRUCTION
7	532 18 37-30	DECAL, REMOTE DEFLECTOR
9	532 41 54-75	DECAL, SPEED CONTROL
11	532 41 53-99	DECAL, LH TRIGGER
12	532 41 53-98	DECAL, RH TRIGGER

NOTE: All component dimensions given in U.S. inches. 1 inch = 25.4 mm
IMPORTANT: Use only Original Equipment Manufacturer (O.E.M.) replacement parts.
Failure to do so could be hazardous, damage your snow thrower and void your warranty.