



SERVICE PARTS LIST

BUL.54-10-2024

1/2" ELECTRIC DRILL

REVISED BUL 6142-5 DATE Nov. '68

Catalog No. 1650-1

Starting Serial No. 142-8795

WIRING INSTR. 58-01-0530

Both Model and Serial No. must be furnished to obtain correct parts.

230V MOTOR ★ 16-66-1011 Armature 18-66-1000 Field

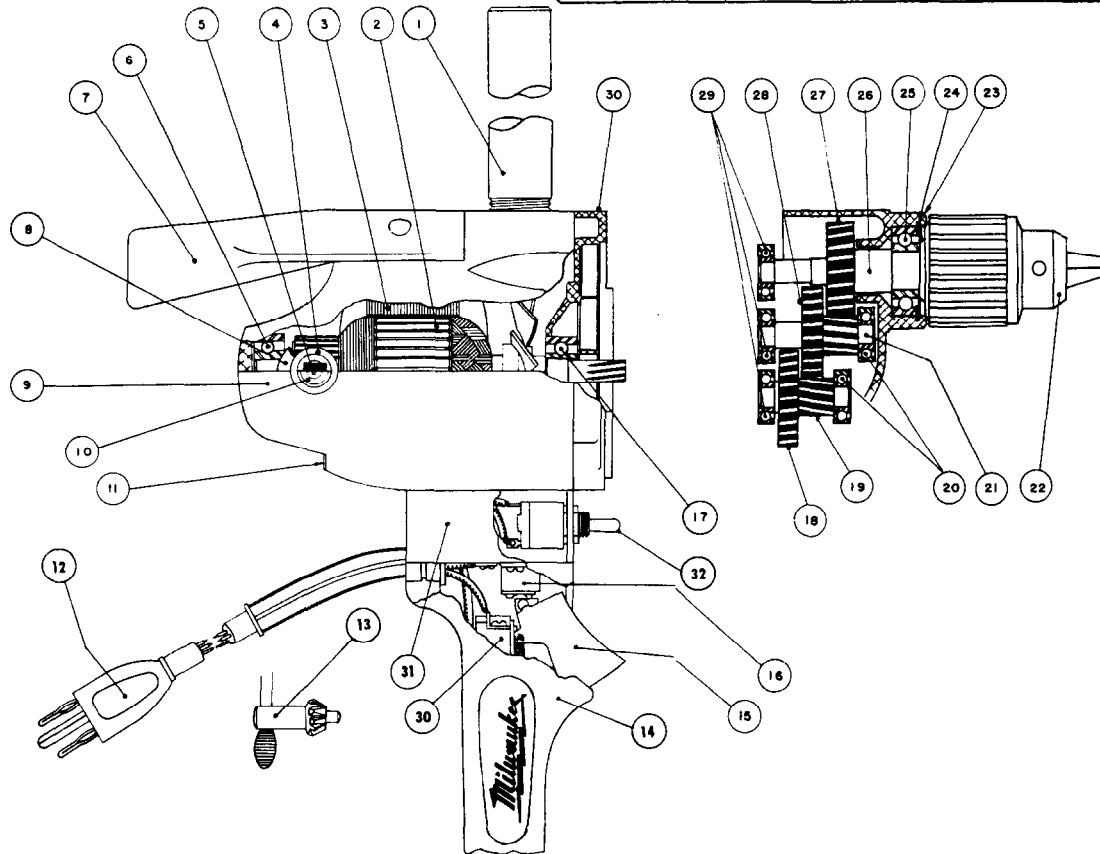

ILLUSTRATED PARTS

FIG.	PART NO.	DESCRIPTION OF PART	NO.REQ.	FIG.	PART NO.	DESCRIPTION OF PART	NO.REQ.
1	43-62-0230	Pipe Handle		17	02-04-1070	Ball Bearing	
2	16-62-1150	Armature Assembly		18	32-42-1221	1st Intermediate Gear	
3	18-62-1110	Field Assembly		19	36-66-2201	1st Intermediate Pinion Shaft	
4	22-22-0120	Brush Holder Assembly	(2)	20	02-04-0820	Ball Bearing	(2)
5	22-18-0170	Carbon Brush Assembly	(2)	★21	36-66-2252	2nd Inter. Pinion Shaft	
6	02-04-0970	Ball Bearing		22	48-66-1380	Chuck (5/8-16) (See Price Sheet)	
7	28-44-7041	Spade Handle		23	28-14-0762	Gear Case	
8	23-86-0130	Brush Holder Washer	(2)	24	34-80-2500	Spindle Ball Brg. Retaining Ring	
9	28-50-4644	Drill Body		25	02-04-1650	Ball Bearing	
10	23-44-0065	Brush Retaining Screw	(2)	26	38-50-2651	Spindle	
11	44-66-0140	Air Intake Cover Plate		★27	32-75-2701	Spindle Gear	
12	22-64-0170	Cord Set (3 Wire - 3 Prong Plug)		28	32-44-1161	2nd Intermediate Gear	
13	48-66-3280	Chuck Key		29	02-04-0820	Ball Bearing	(3)
14	28-44-9121	Switch Handle		30	28-28-0701	Diaphragm	
15	23-66-0190	Switch		31	28-50-7081	Rev. Switch Housing	
16	42-36-0180	Switch Bracket		32	23-66-0198	Reverse Switch	

MISCELLANEOUS PARTS NOT SHOWN

PART NO.	DESCRIPTION OF PART	NO.REQ.	PART NO.	DESCRIPTION OF PART	NO.REQ.
42-70-0060	Spade Handle Key Clip		06-81-8650	6-32x1/4" Rd.Hd. Sems Comm. Cover Plate Screws	(2)
12-98-3725	Name Plate		06-81-8200	4-36x3/16" Rd. Hd. Name Plate Screws	(2)
06-42-2000	Spindle Woodruff Key		06-83-2670	1/4"-20 x 1/2" Hd'less Brush Holder Set Screws	(2)
06-42-0800	Int. Shaft Woodruff Key	(2)	06-81-8650	6-32 x 1/4" Rd.Hd. Sems Switch Bracket Screws	(2)
06-81-7100	10-24x1-3/16" Fil.Hd. Sems Gear Case Scrs.	(2)	06-81-5800	6-32x5/16" Fil.Hd. Sems Switch Mounting Screw	(2)
06-81-7200	10-24x1-7/16 Fil.Hd.Sems Gear Case Sr.(top)	(2)	06-81-8650	6-32x1/4 Rd. Hd. Sem Key Clip Screws	(2)
06-81-6700	8-32x1-7/8" Fil. Hd. Field Screws	(2)	06-75-3150	1/4-20x1 Skt.Hd. Chuck Cap Screw (L.H.)	
★ 06-81-7590	12-24X 1 3/4 Fil. Hd. Sem Sw. Handle Scr.	(4)	45-30-0060	Ball Bearing Ret. Plug	(3)
06-81-7500	12-24x5/8" Fil.Hd. Sems Spade Handle Srs.	(2)	42-68-0090	Lead Clamp	
48-03-0010	Attach. Plug Adaptor		06-81-8625	6-32x 1/4" Rd. Hd. Brass Ground Screw (Sem)	
06-97-1800	Switch Lock Washers	(4)	22-75-0055	Switch Dial	
06-97-3600	Lock Washers	(4)			

★ NOTE

To Order Replacement Jaw and Nut Unit For Chuck, Order Part No. 43-90-0160