



# SERVICE PARTS LIST

**BULLETIN NO.**  
54-12-1303

SPECIFY CATALOG NO. AND SERIAL NO. WHEN ORDERING PARTS		REVISED BULLETIN 54-12-1302	DATE JUNE '87
<b>SUPER HOLE-SHOOTER</b>		WIRING INSTRUCTION <b>58-01-0940</b>	
<b>CATALOG NO. 1854-1</b>	STARTING SERIAL NO. 567-18000		

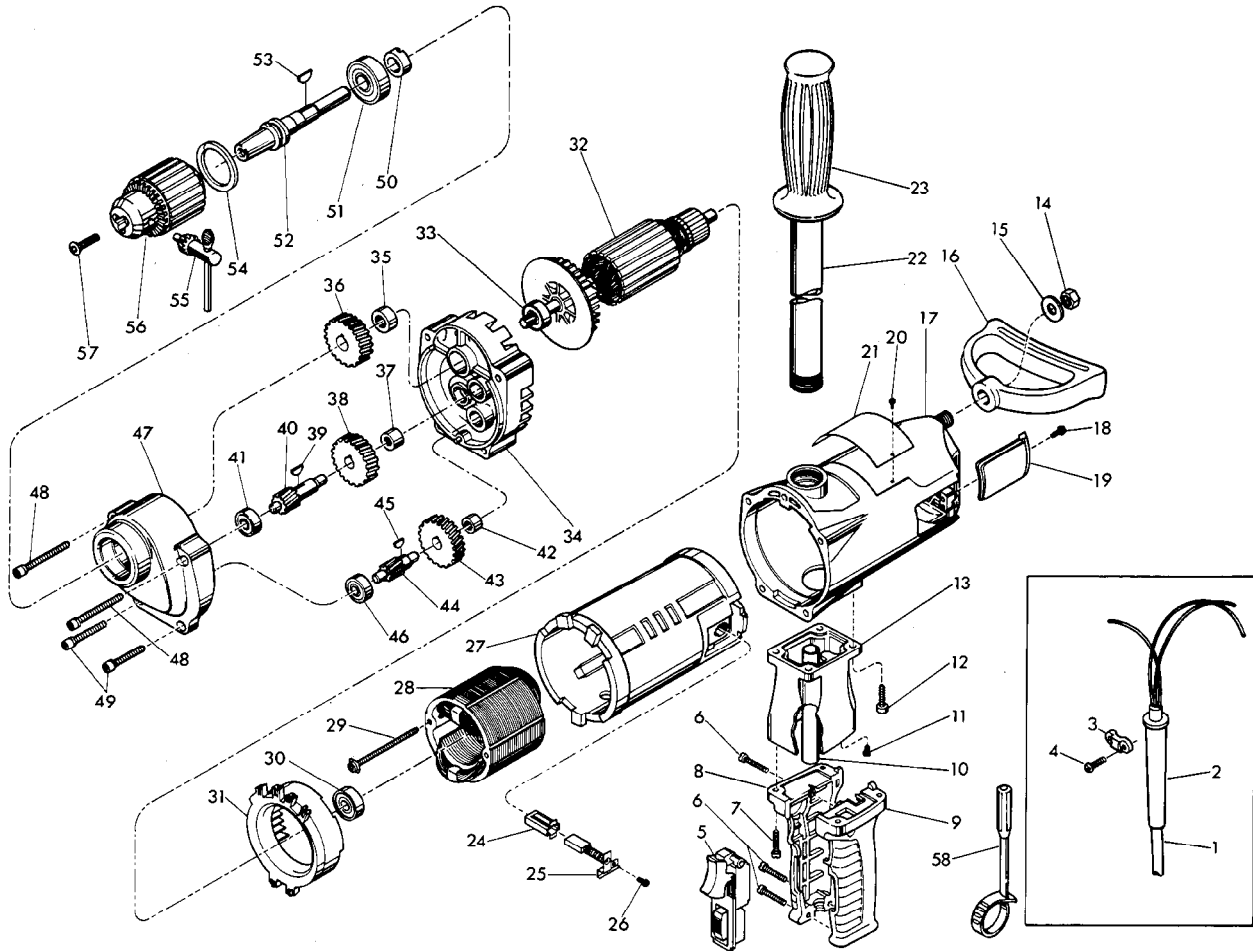

FIG.	CAT. NO.	DESCRIPTION OF PART	NO. REQ.
1	22-64-0121	Cord Set	(1)
★ 2	44-76-0140	Cord Protector	(1)
★ 3	31-17-0156	Cord Clamp	(1)
★ 4	06-82-7270	8-16x5/8" Slotted Torx Plast. Screw	(2)
★ 5	23-66-1420	Switch	(1)
6	06-82-7326	8-16x1" Slotted Torx Plast. Screw	(3)
7	06-82-5358	12-24x3/4" Pan Hd. Tapitite Screw	(4)
8	31-44-1440	Right Handle Half	(1)
9	31-44-1445	Left Handle Half	(1)
★ 10	23-16-1440	Insulating Tube	(1)
★ 11	06-95-5200	8-32 x 5/16" Ground Screw	(1)
★ 12	06-95-5645	1/4-20x3/4" Pan Hd. Tapitite Screw	(4)
★ 13	28-86-1611	Handle Spacer	(1)
14	06-55-2850	1/2 - 13 Hex Nut	(1)
★ 15	45-88-7150	Thrust Washer	(1)
★ 16	31-44-1450	Spade Handle	(1)
★ 17	28-50-6365	Motor Housing	(1)
★ 18	06-14-0010	1/2 x 13 x 1-3/8" Hex Hd. Bolt	(1)
★ 19	06-82-7252	8-32x3/8" Slotted Pan Hd. Tapitite Screw	(2)
★ 20	22-32-0350	Brush Cover	(2)
★ 21	06-85-0200	Nameplate Screw	(2)
★ 22	12-15-7010	Service Nameplate	(1)
★ 23	43-62-0121	Pipe Handle	(1)
★ 24	43-62-0246	Handle Grip	(1)
★ 25	22-20-0680	Brush Tube	(2)
★ 26	22-18-0700	Carbon Brush Assembly	(2)
★ 27	06-82-8835	8-32 x 5/16" Pan Torx Sems	(2)
★ 28	23-16-1420	Insulated Housing	(1)
★ 29	18-70-0310	120 Volt Field	(1)
★ 30	06-82-9072	10-24x2-1/8" Pan Hd. Sems	(2)
★ 31	02-04-1041	Ball Bearing	(1)

FIG.	CAT. NO.	DESCRIPTION OF PART	NO. REQ.
★ 31	42-14-0291	Baffle	(1)
★ 32	16-70-0340	120 Volt Armature	(1)
★ 33	22-84-0790	Fan	(1)
★ 34	02-04-1229	Ball Bearing	(1)
★ 35	14-13-0240	Diaphragm	(1)
★ 36	06-65-1155	Pin	(1)
★ 37	02-50-4040	Needle Bearing	(1)
★ 38	32-75-1001	Spindle Gear	(1)
★ 39	02-50-2450	Needle Bearing	(1)
★ 40	32-44-1181	Intermediate Gear	(1)
★ 41	06-42-1600	Woodruff Key	(1)
★ 42	36-66-0501	Intermediate Shaft	(1)
★ 43	02-04-0910	Ball Bearing	(1)
★ 44	02-50-2450	Needle Bearing	(1)
★ 45	32-40-1001	Intermediate Gear	(1)
★ 46	36-66-2601	Intermediate Pinion Shaft	(1)
★ 47	06-42-1200	Woodruff Key	(1)
★ 48	02-04-0910	Ball Bearing	(1)
★ 49	28-14-0401	Gear Case	(1)
★ 50	06-82-8440	1/4-20x2-1/2" Fil. Tapitite Torx Sems	(2)
★ 51	06-82-8330	1/4-20x1-7/8" Fil. Tapitite Torx Sems	(2)
★ 52	45-36-0200	Spacer	(1)
★ 53	02-04-2031	Ball Bearing	(1)
★ 54	38-50-5500	Reversing Spindle	(1)
★ 55	06-42-2400	Woodruff Key	(1)
★ 56	34-80-3450	Retaining Ring	(1)
★ 57	48-66-3160	Chuck Key	(1)
★ 58	48-66-2085	Chuck (Includes Fig. No. 55)	(1)
★ 59	06-81-3100	5/16-18x1" Socket Hd. Screw	(1)
★ 60	48-66-4020	Chuck Key Holder	(1)

**FIG. 12 NOTES**  
Tighten one screw until lockwasher is touching handle spacer. Tighten the diagonally opposite screw (70 - 80 lbs./in. on new motor housing) and then sequentially tighten the other screws.  
Apply Type 242 Blue Loctite.

**FIG. 47 LUBRICATION**  
7 - 3/4 oz. "E" Grease, No. 49-08-4121.