

## Impact Wrench - 3 601 J09 312 - 22618

www.powertools-aftersaleservice.com



**BOSCH**

Item	Part Number	Description	Illustration	Price	Quantity	Price Group
	1 2 609 100 461	Housing BLUE	1	-,-	1	30
	4 2 607 200 489	On-Off Switch	1	-,-	1	32
	5 2 609 100 273	Button	1	-,-	1	13
	7 2 609 100 297	Contact retainer	1	-,-	1	22
	8 2 609 130 720	Warning Plate 9,6V	1	-,-	1	13
	9 2 609 130 991	Manufacturer's nameplate	1	-,-	1	15
	27 2 609 120 146	Connecting Cable 50 MM LONG,BLACK	1	-,-	1	11
	28 2 609 120 147	Connecting Cable 60 MM, LONG, RED	1	-,-	1	11
	45 2 609 199 104	Gear Box	1	-,-	1	45
	45/05 2 609 170 025	Protective Ring	1	-,-	1	20
	50 2 609 199 091	Light-Emitting-Diode	1	-,-	1	27
	91 2 607 335 717	Accumulator Battery 18V,2,4Ah, HD	1	-,-	2	52
	100 2 609 199 027	Holder	1	-,-	1	21
	101 2 609 110 201	Torx Flat-Head Screw 3x16	1	-,-	8	10
	107 2 609 110 327	Screw	1	-,-	4	11
	108 2 609 110 309	Screw	1	-,-	1	11
	111 2 609 100 298	Cover Flap BLACK	1	-,-	1	19
	180 2 609 131 167	Nameplate	1	-,-	1	15
	652 2 609 100 101	Protective Cap	1	-,-	1	16
	653 2 607 225 033	Fast Charger USA 120/7,2-24V, 30 MIN.	1	-,-	1	46
	802 2 609 199 089	Motor 18V	1	-,-	1	42
	802/33 2 609 170 030	O-Ring	1	-,-	1	11
	816 2 609 199 048	Carbon-Brush Set	1	-,-	1	22
	848 2 609 199 049	Sealing cap	1	-,-	1	16

Illustration - Type E

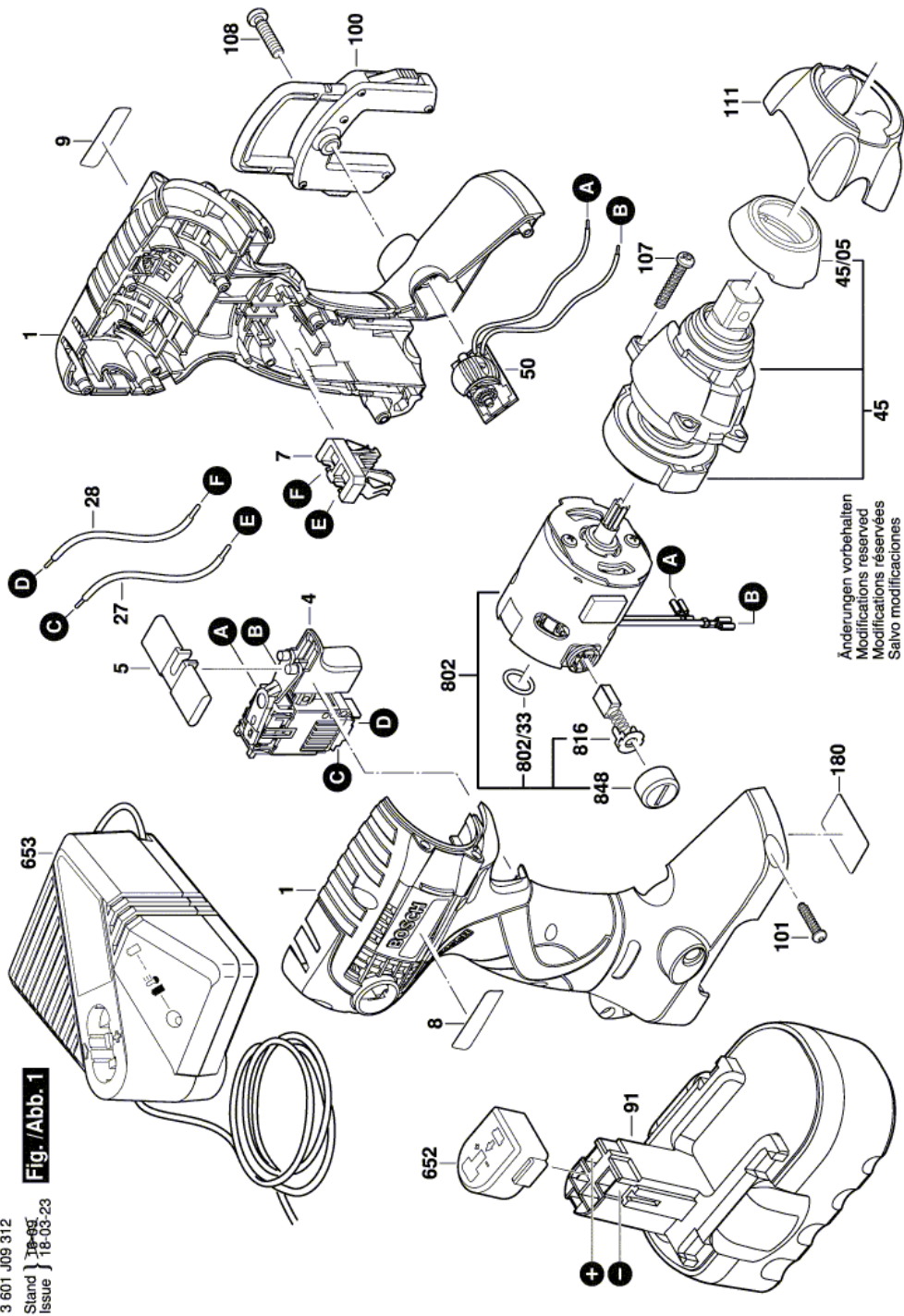

Information subject to change without further notice.