



# SERVICE PARTS LIST

BULLETIN NO.  
55-42-2400

SPECIFY CATALOG NO. AND SERIAL NO. WHEN ORDERING PARTS		REVISED BULLETIN	DATE
<b>M12™ Sub-Compact 1/4" Hex Driver</b>			Sept. 2013
CATALOG NO.	<b>2401-059</b>	STARTING SERIAL NO.	<b>D21A</b>
		WIRING INSTRUCTION <b>SEE NOTES</b>	

**EXAMPLE:**  

00	0
----	---

 Component Parts (Small #) Are Included  
 When Ordering The Assembly (Large #).

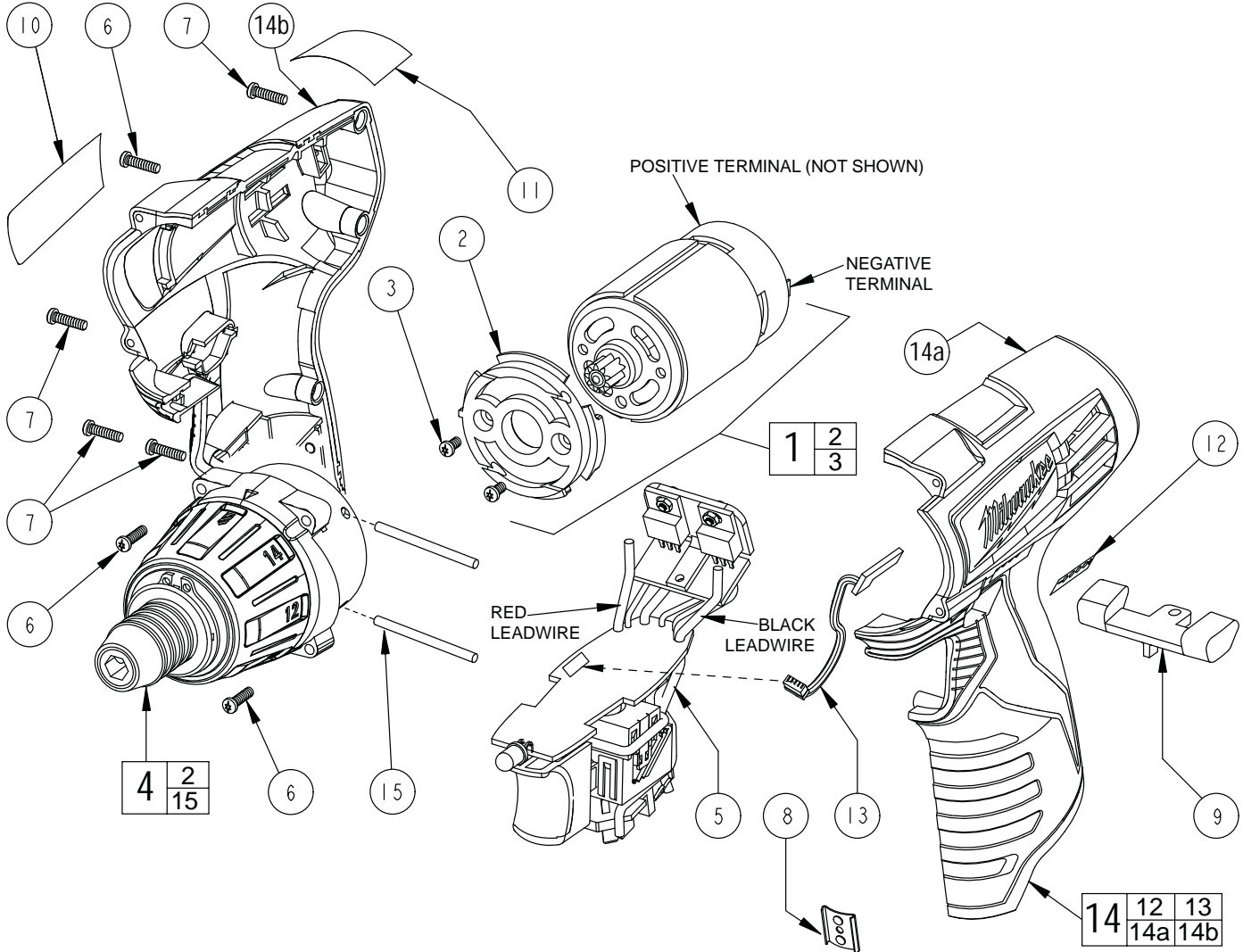

FIG.	PART NO.	DESCRIPTION OF PART	NO. REQ.
1	23-30-0095	Motor assembly	(1)
2	44-66-0155	Motor mount plate	(1)
3	05-81-0205	Screw	(2)
4	14-29-0095	Gearcase assembly	(1)
5	23-66-1096	Variable electronics switch assembly	(1)
6	06-82-2400	Screw	(5)
7	06-82-2395	Screw	(4)
8	42-70-0055	Housing clip	(1)
9	45-24-0095	Forward/reverse button	(1)
10	-----	Service nameplate	(1)
11	10-15-0956	Warning label	(1)
12	10-20-0760	Fuel gauge label	(1)
13	22-09-0075	Fuel gauge	(1)
14	31-50-2400	Housing assembly	(1)
14a	-----	Housing half- left	(1)
14b	-----	Housing half- right	(1)
15	-----	Metal pin	(2)

**NOTES:**

1,2,4 **IMPORTANT: See the back side of this bulletin if servicing the motor assembly (1) or the gearcase assembly (4).**

5, 1 Solder red lead wire from electronics module assembly (5) to positive terminal (red) of Motor Assembly. Solder black lead wire from electronics module assembly (5) to negative terminal of Motor Assembly.

5, 13 Insert the fuel gauge (13) wire assembly into the electronics module assembly.

**SUBJECT: 23-30-0095 MOTOR ASSEMBLY with NYLON or ALUMINUM Motor Mount Plate**  
**14-29-0095 GEARCASE ASSEMBLY with NON-MACHINED or MACHINED Gearcase**

Motor Mount Plate of service replacement 23-30-0095 MOTOR ASSEMBLY can be either NYLON or ALUMINUM.

When replacing either the 23-30-0095 MOTOR ASSEMBLY or 14-29-0095 GEARCASE ASSEMBLY the mating of the motor assembly with the gearcase **is dependent on the original motor mount plate** the Hex Driver **original motor** has a nylon motor mount then replace any service replacement MOTOR ASSEMBLY aluminum motor mount with the original nylon motor mount plate from the original motor before installing it to the gearcase and vice versa - if the original motor has a aluminum motor mount then replace the service replacement MOTOR ASSEMBLY nylon motor mount with the original aluminum before installing to the gearcase.

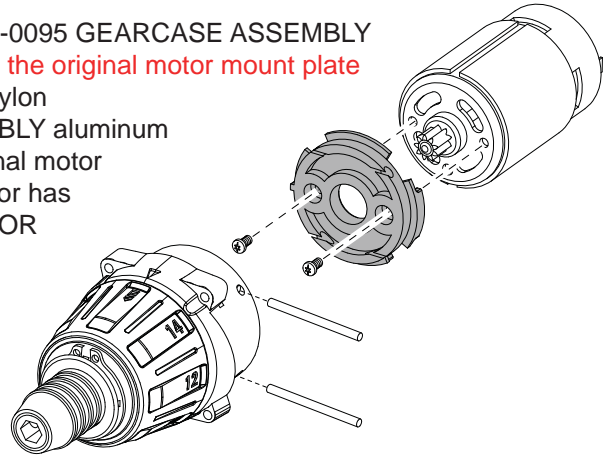

**NON-MACHINED GEARCASE**  
Nylon Motor Mount Plate must be used

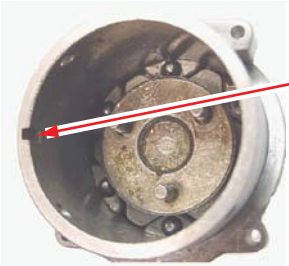

Notch for Nylon Motor Mount Alignment Tab will be utilized

**MACHINED GEARCASE**  
Aluminum Motor Mount Plate must be used



Gearcase has machined undercut

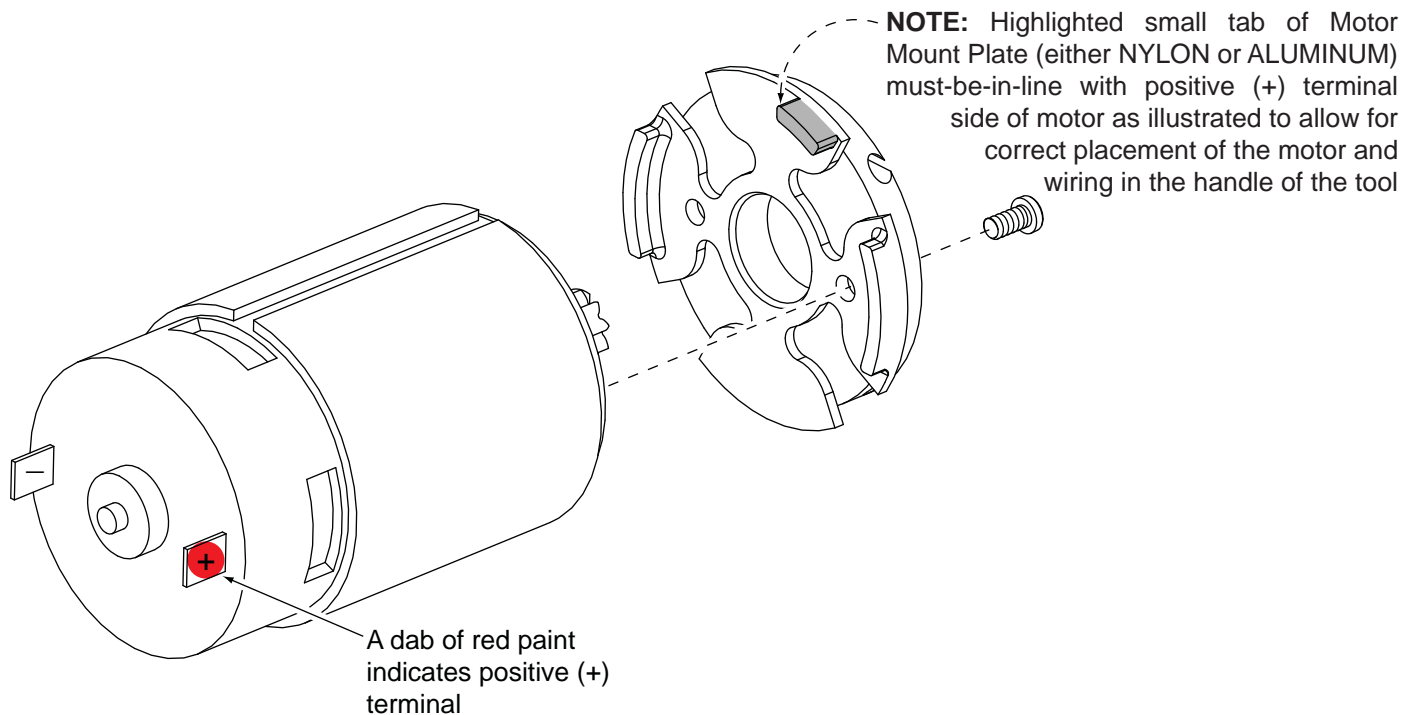

**NOTE:** Highlighted small tab of Motor Mount Plate (either NYLON or ALUMINUM) must-be-in-line with positive (+) terminal side of motor as illustrated to allow for correct placement of the motor and wiring in the handle of the tool

A dab of red paint indicates positive (+) terminal