



SERVICE PARTS LIST

BULLETIN NO.
54-40-6512

SPECIFY CATALOG NO. AND SERIAL NO. WHEN ORDERING PARTS		REVISED BULLETIN	DATE
M12™ Hackzall®		54-40-6511	Feb. 2014
CATALOG NO.	2420-20	WIRING INSTRUCTION SEE REVERSE SIDE	
	STARTING SERIAL NO.	B56C	

EXAMPLE:
Component Parts (Small #)
Are Included When Ordering
The Assembly (Large #).

★ = Part number change from
previous service parts list.



NOTE:
Clean bevel gear assembly
[29,30,31,32 & 33] with a clean,
dry cloth. **DO NOT** wash up.

Lock Pin (14) to be
coated with graphite
prior to assembly.

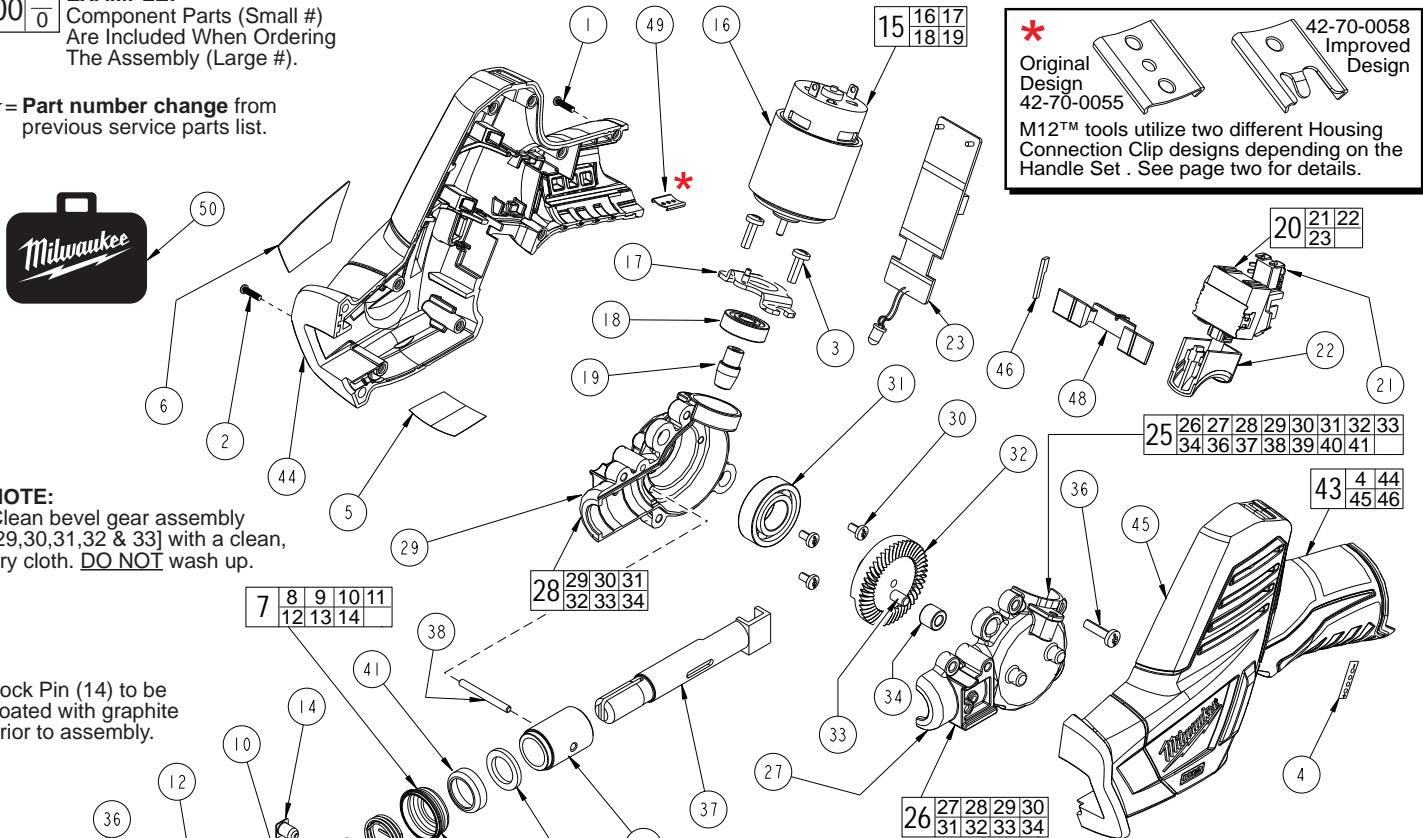

★ Original Design 42-70-0055 Improved Design 42-70-0058

M12™ tools utilize two different Housing Connection Clip designs depending on the Handle Set. See page two for details.

FIG.	PART NO.	DESCRIPTION OF PART	NO. REQ.
1	06-82-2395	M2.6 x 10 Pan Hd. T-9 Screw	(3)
2	06-82-2385	M2.6 x 14 Pan Hd. T-9 Screw	(5)
3	06-82-2380	8-32 x 1/2" Pan Hd. Tapt. T-20 Screw	(2)
4	10-20-0304	Fuel Gauge Label	(1)
5	10-15-0955	Warning Label	(1)
6	12-20-2421	Service Nameplate Kit	(1)
7	14-46-1011	Steel Quik-Lok Blade Clamp	(1)
8	31-15-0511	Spring Cover	(1)
9	42-50-0076	Front Cam	(1)
10	42-50-0077	Rear Cam	(1)
11	45-22-0081	Sleeve	(1)
12	34-60-3680	Retaining Ring	(1)
13	40-50-0161	Torsion Spring	(1)
14	44-60-0626	Lock Pin	(1)
15	23-30-0020	Motor Assembly	(1)
16	-----	Motor	(1)
17	-----	Motor Mounting Plate	(1)
18	-----	Ball Bearing	(1)
19	-----	Pinion	(1)
★ 20	23-66-0318	Switch & PCB Assembly	(1)
21	-----	Terminal Block	(1)
22	-----	Switch	(1)
23	-----	PCB Assembly	(1)
25	28-14-0030	Gearcase Assembly	(1)
26	14-30-0035	Gearcase Set	(1)
27	-----	Left Gearcase	(1)
28	14-30-0925	Right Gearcase Kit	(1)
29	-----	Right Gearcase	(1)
30	-----	6-32 x 1/4" Pan Hd. Slit. T-15 Screw	(3)

FIG.	PART NO.	DESCRIPTION OF PART	NO. REQ.
31	-----	Ball Bearing	(1)
32	-----	Bevel Gear	(1)
33	-----	Drive Pin	(1)
34	44-86-0085	Bearing Sleeve	(1)
36	06-82-5320	8-32 x 5/8" Pan Hd Slit. T-20 Screw	(6)
37	38-50-0015	Spindle	(1)
38	06-65-0070	Spindle Guide Pin	(1)
39	42-40-0120	Bushing	(1)
40	45-06-0035	Felt	(1)
41	44-86-0095	Cap	(1)
43	31-44-0115	Handle Set	(1)
44	-----	Right Handle Halve	(1)
45	-----	Left Handle Halve	(1)
46	-----	Fuel Gauge LED	(1)
47	45-16-0040	Shoe	(1)
48	45-24-0150	Shuttle	(1)
49	42-70-0055	Housing Connection Clip	(1)
50	42-55-2420	Carrying Case, Optional	(1)

★ **LUBRICATION NOTE:** When servicing the Gears (19 & 32) or the Gearcase Assembly (25), 90-95% of the old grease must be removed prior to new 'J' grease being added.

- FIG. LUBRICATION** (*See lubrication note above)
(Type 'J' Grease, No. 49-08-4220):
- 19,32 Completely coat all of the teeth of the Pinion (19) and Bevel Gear (32) with grease.
 - 27,29 Place a small amount of grease in Gearcase cavities.
 - 33,34 Lightly coat the Drive Pin (33) and I.D. and O.D. of Bearing Sleeve (34) with grease.
 - 37 Place a dab of grease in the side slot and the rear pocket of Spindle (37).
 - 37,39 Lightly coat the O.D. of Spindle (37) and I.D. of Bushing (39) with grease.
 - 40,41 Saturate Felt (40) with lightweight oil prior to assembly with Cap (41) onto Bushing (39) and Spindle (37).

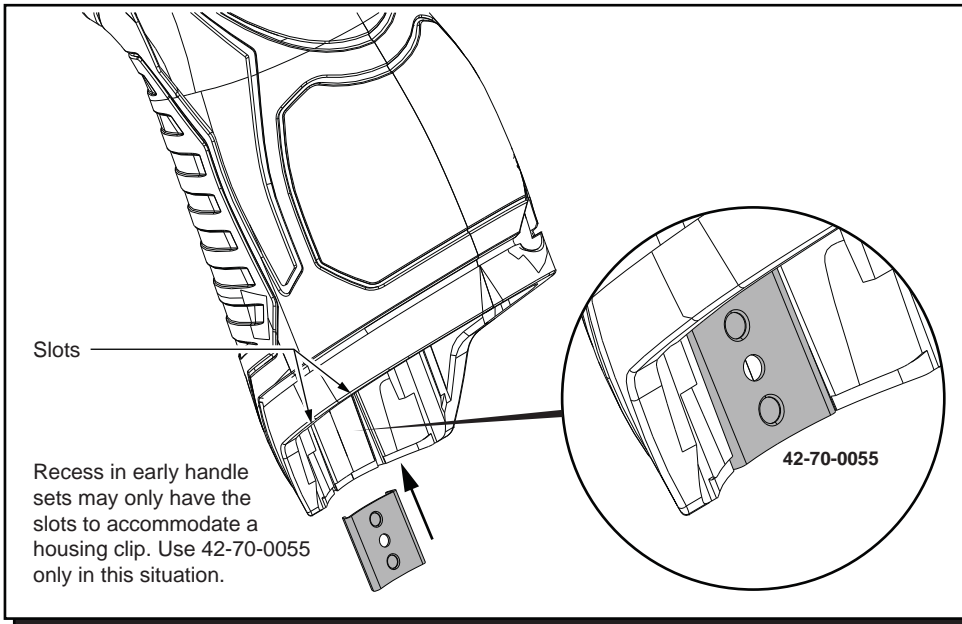

Early M12™ Handle Sets utilize **Housing Connection Clip No. 42-70-0055**. Install this clip design by aligning the side rails of the clip with the two slots in the handle set. Gently push into place with the aid of a small flat blade screwdriver or a similar instrument. Be sure that the clip is properly seated in both slots and that the clip is flush to sub-flush to the end of the handle set. To remove the clip, use the same small flat blade screwdriver or a similar instrument and push the clip out of the handle set. If the clip is loose or will not stay in place, a needle nose pliers can be used to gently bend/pinch the side rails of the clip. If the clip is damaged do not use, replace with a new 42-70-0055 housing clip.

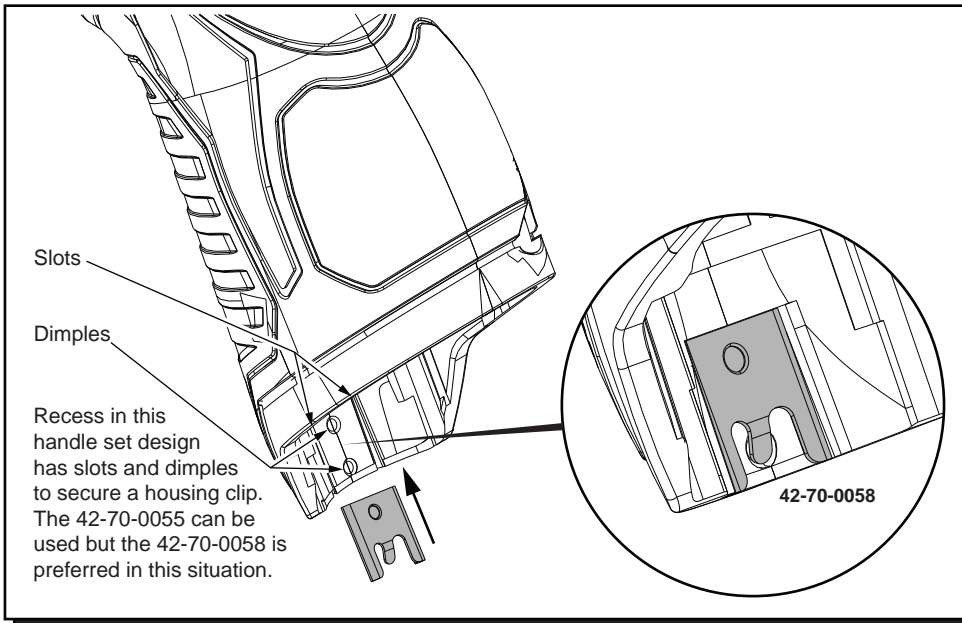

Updated M12™ Handle Sets utilize **Housing Connection Clips No. 42-70-0055 and 42-70-0058. (The 42-70-0058 is a preferred upgrade)**. Install this clip design by aligning the side rails of the clip with the two slots in the handle set. Gently push into place with the aid of a small flat blade screwdriver or a similar instrument. Be sure that the clip is properly seated in both slots and that the tab of the clip snaps down in the round dimpled cavity of the handle set. Be sure that the clip is flush to sub-flush to the end of the handle set. To remove the clip, use the same small flat blade screwdriver or a similar instrument and lift up on the clip tab while pushing the clip out of the handle set. Use a needle nose pliers to gently rebend the clip tab if necessary. If the tab on the clip is damaged during this process and is loose or will not stay in place, replace with a new 42-70-0058 clip.

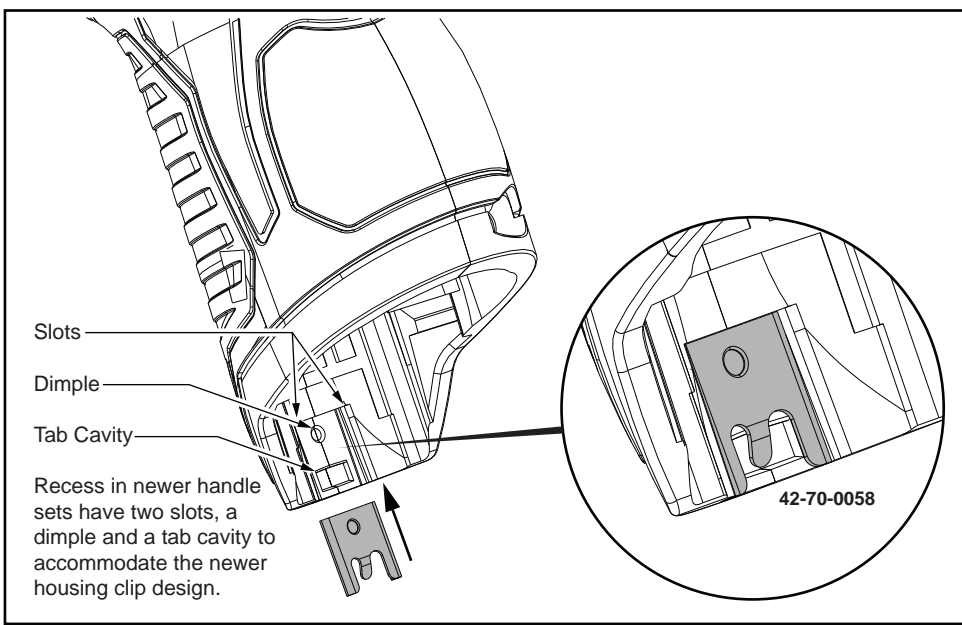

Newer M12™ Handle Sets utilize **Housing Connection Clip No. 42-70-0058**. Install this clip design by aligning the side rails of the clip with the two slots in the handle set. Gently push into place with the aid of a small flat blade screwdriver or a similar instrument. Be sure that the clip is properly seated in both slots and that the tab of the clip snaps down in the rectangular cavity of the handle set. Be sure that the clip is flush to sub-flush to the end of the handle set. To remove the clip, use the same small flat blade screwdriver or a similar instrument and lift the clip tab out of the cavity while pushing the clip out of the handle set. Use a needle nose pliers to gently rebend the clip tab if necessary. If the tab on the clip is damaged during this process and is loose or will not stay in place, replace with a new 42-70-0058 clip.

Disassembly

3-15-25-36

Motor assembly [15] can be easily removed from gearcase assembly [25] by removing screws [3] and loosening two screws [36] from the motor ball bearing [18] area of gearbox [25]

5 - 43

Before separating housing set [43] carefully cut thru the center of warning label [5] following the seam of the housing halves

Reassembly

15 - 17 -25

When reinstalling motor assembly [15] into gearcase assembly [25] make sure alignment pin side of motor mounting plate [17] faces top of Gearcase assembly [25] (Fig. A)

29 -38

Press spindle guide pin [38] flush to outside casting of right gearcase [29]

20 - 23 - 45

When reassembling switch assembly [20 / 23] into left motor housing half [45], place LED into housing first then position LED wiring into housing wire traps as shown in (Fig. B)

23 - 45 - 48

For proper back and forth movement of shuttle [48] PCB [23] must be inserted into left housing half [45] support slots as shown in (Fig. C)

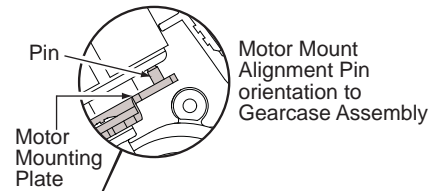

Fig. A

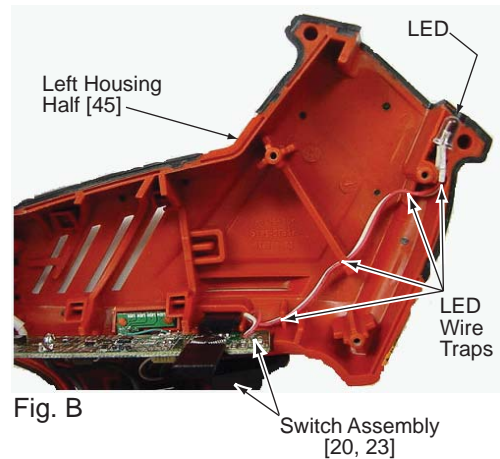

Fig. B

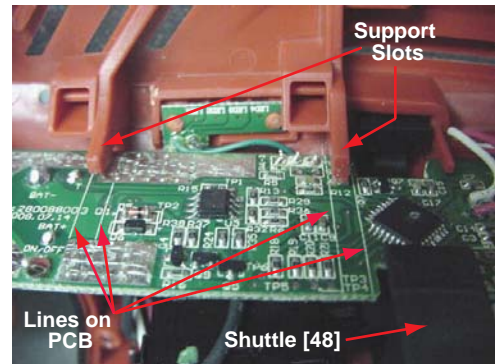
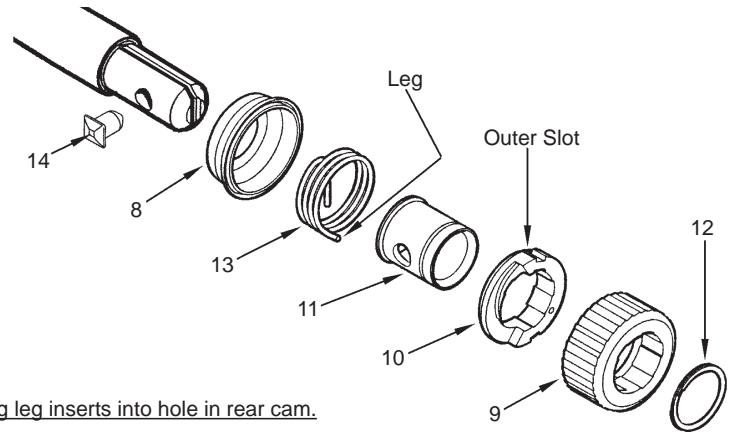

Fig. C

PCB Support slots found in Left Housing Half must align with lines on PCB for proper shuttle movement

REMOVING THE STEEL QUIK-LOK® BLADE CLAMP

- Remove external retaining ring (12) and pull front cam (9) off.
- Pull lock pin (14) out and remove remainder of parts and discard.



REASSEMBLY OF THE STEEL QUIK-LOK® BLADE CLAMP

- Coat new lock pin with powdered graphite.
- Hold tool in a vertical position.
- Place spring cover (8) onto spindle.
- Slide torsion spring (13) onto spindle with spring leg on hole side of spindle.
- Slide sleeve (11) onto spindle aligning hole on sleeve with hole in spindle.
- Slide rear cam (10) over sleeve until it bottoms on sleeve shoulder, ensure spring leg inserts into hole in rear cam.
- Rotate rear cam in the direction of the arrows located on spring cover until there is clearance for lock pin (14) to be inserted into sleeve/spindle holes. Insert lock pin.
- Align front cam (9) inner ribs with rear cam outer slots and slide front cam onto sleeve until it bottoms. Retaining ring (12) groove should be completely visible.
- Attach retaining ring by separating coils and inserting end of ring into groove, then wind remainder of ring into groove. Ensure ring is seated in groove.
- Blade clamp should rotate freely. During normal usage, debris may not allow blade clamp to rotate freely. The use of spray lubricant can help free blade clamp. In extreme conditions, follow these instructions to remove, clean and reassemble blade clamp.

AS AN AID TO REASSEMBLY, TAKE NOTICE OF WIRE ROUTING AND POSITION IN WIRE GUIDES AND TRAPS WHILE DISMANTLING TOOL.

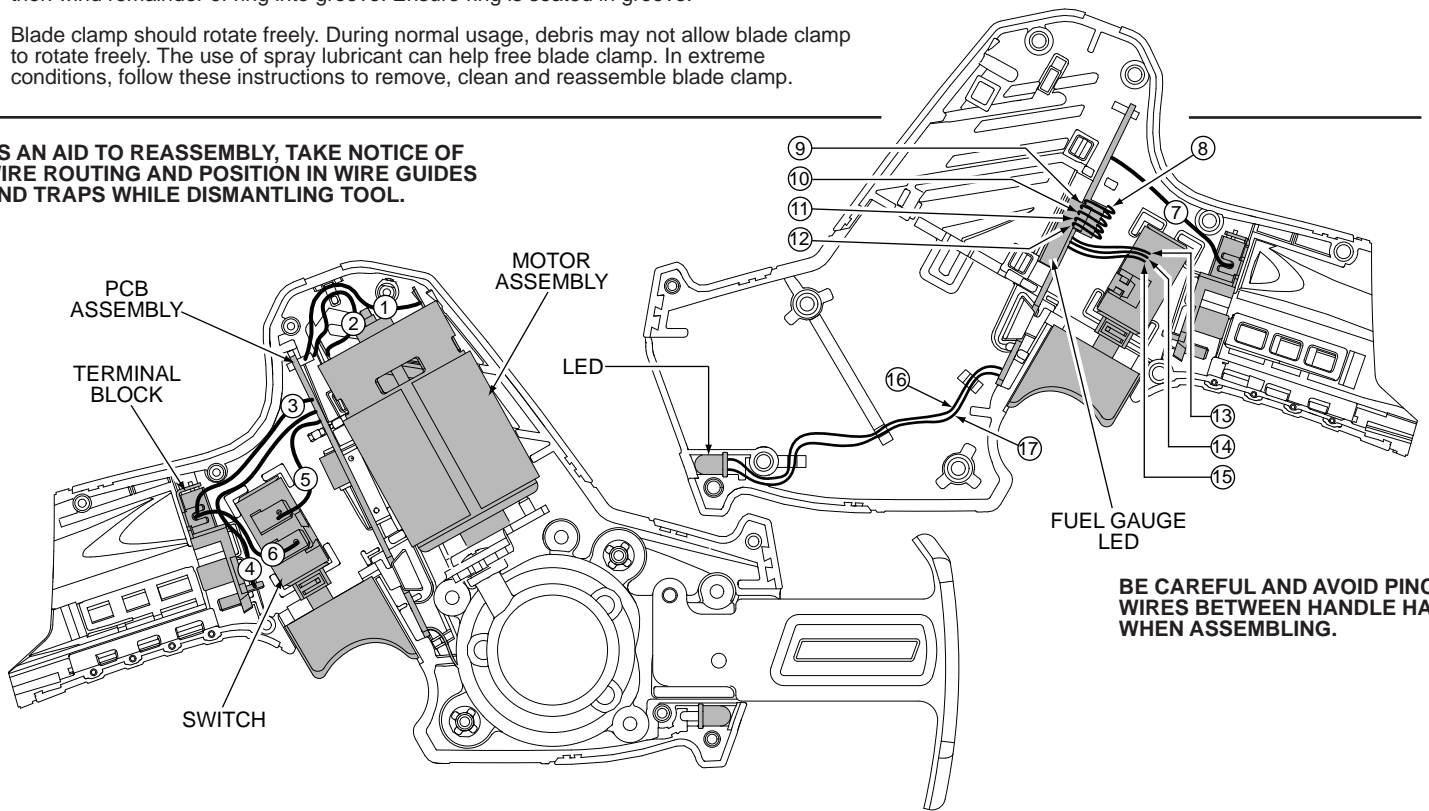

BE CAREFUL AND AVOID PINCHING WIRES BETWEEN HANDLE HALVES WHEN ASSEMBLING.

WIRING SPECIFICATIONS

Wire No.	Wire Color	Origin or Gauge	Length	Terminals, Connectors and 1 or 2 End Wire Preparation
1	Red	-----	-----	Component of the Switch & PCB Assembly.
2	White	-----	-----	Component of the Switch & PCB Assembly.
3	Red	-----	-----	Component of the Switch & PCB Assembly.
4	White	-----	-----	Component of the Switch & PCB Assembly.
5	Black	-----	-----	Component of the Switch & PCB Assembly.
6	Red	-----	-----	Component of the Switch & PCB Assembly.
7	Black	-----	-----	Component of the Switch & PCB Assembly.
8	Gray	-----	-----	Component of the Switch & PCB Assembly.
9	Green	-----	-----	Component of the Switch & PCB Assembly.
10	Red	-----	-----	Component of the Switch & PCB Assembly.
11	Black	-----	-----	Component of the Switch & PCB Assembly.
12	White	-----	-----	Component of the Switch & PCB Assembly.
13	Yellow	-----	-----	Component of the Switch & PCB Assembly.
14	Blue	-----	-----	Component of the Switch & PCB Assembly.
15	Black	-----	-----	Component of the Switch & PCB Assembly.
16	Red	-----	-----	Component of the Switch & PCB Assembly.
17	White	-----	-----	Component of the Switch & PCB Assembly.