



# SERVICE PARTS LIST

**BULLETIN NO.**  
54-26-2462

SPECIFY CATALOG NO. AND SERIAL NO. WHEN ORDERING PARTS				REVISED BULLETIN	DATE
<b>12 Volt 3/8" Square Drive Impact Wrench</b>				54-26-2461	Mar. 2013
CATALOG NO.	<b>2451-20</b>	STARTING SERIAL NO.	<b>C08C</b>	WIRING INSTRUCTION <b>SEE PAGE THREE</b>	

**EXAMPLE:**  
Component Parts (Small #)  
Are Included When Ordering  
The Assembly (Large #).



NOTE: Gear Assembly (28) must be attached to the Motor Assembly (7) prior to installing in Gearcase Assembly (36).

Service replacement Gear Assembly (28) comes with a motor mount plate that must be removed and discarded when servicing. A Motor Mount Plate (10) already exists on the Motor Assembly (7).

★ = Part number change from previous service parts list.

NOTE: Pins (13) are shorter than Pins (32).

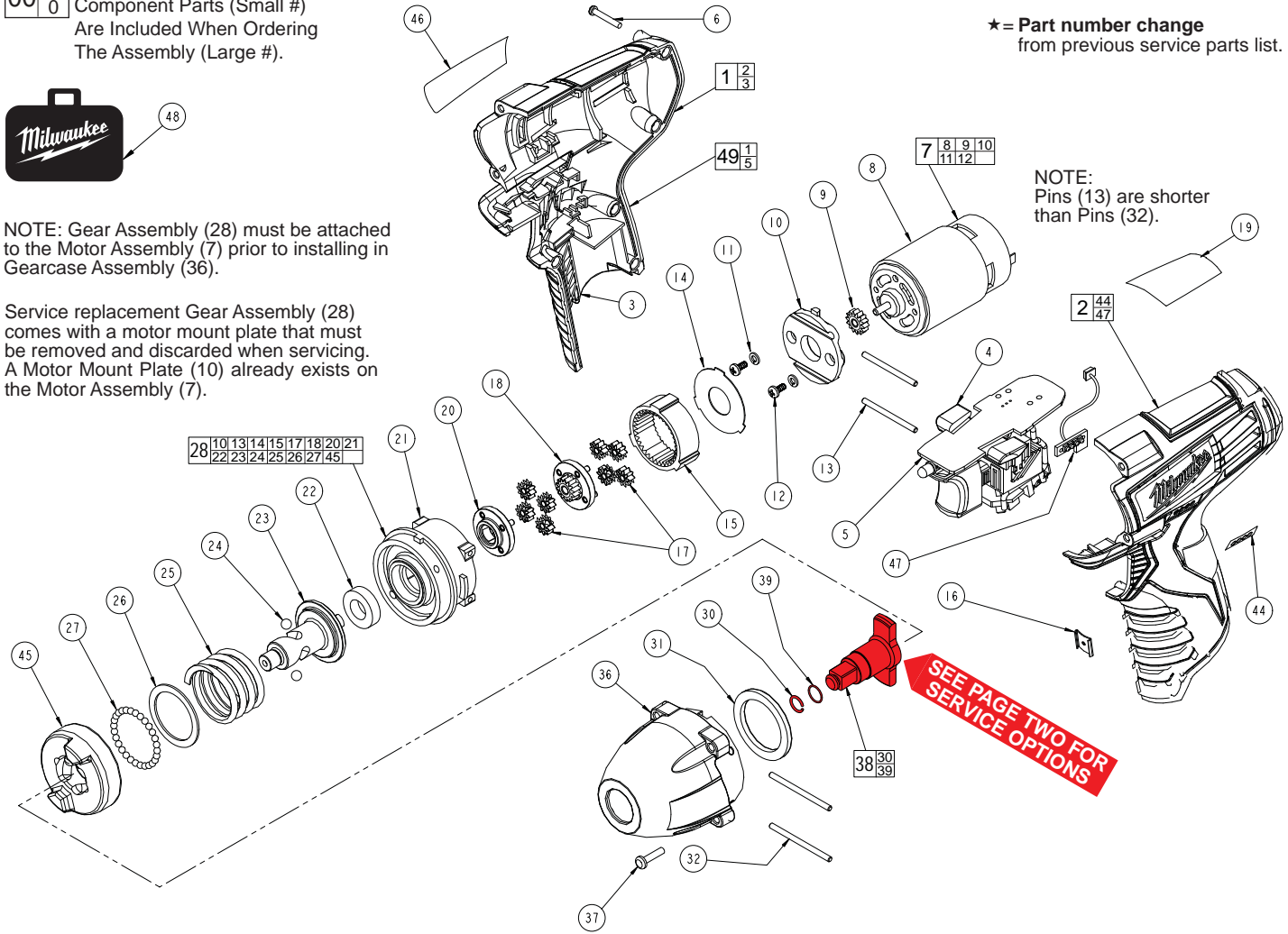

FIG.	PART NO.	DESCRIPTION OF PART	NO. REQ.	FIG.	PART NO.	DESCRIPTION OF PART	NO. REQ.
★ 1	31-50-2403	Handle Set	(1)	30	-----	Hog Ring <i>(See page two)</i>	(1)
2	-----	Left Handle Half	(1)	31	45-88-0455	Washer	(1)
3	-----	Right Handle Half	(1)	32	06-65-0085	Pin	(2)
4	45-24-0105	Fwd./Rev. Button	(1)	36	14-30-0005	Gearcase Assembly with Bushing	(1)
★ 5	23-66-1132	Electronics Module Assembly	(1)	37	06-81-0005	M3.5 x 24 Screw	(4)
6	06-82-2385	M2.6 x 14 T-9 Screw	(5)	38	-----	Anvil Assembly <i>(See page two)</i>	(1)
7	23-30-0090	Motor Service Assembly	(1)	39	-----	Rubber Ring <i>(See page two)</i>	(1)
8	-----	Motor	(1)	44	-----	LED Label	(1)
9	-----	Pinion	(1)	45	-----	Hammer	(1)
10	-----	Motor Mount	(1)	46	12-20-2452	Service Nameplate	(1)
11	-----	Washer	(2)	47	-----	Fuel Gauge LED Assembly	(1)
12	-----	M3 x 6 Screw	(2)	48	42-55-2450	Carrying Case, Optional	(1)
13	06-65-0075	Pin	(2)	★ 49	14-46-1705	Handle Set and Switch Assembly	(1)
14	-----	Washer	(1)				
15	-----	Ring Gear	(1)				
16	42-70-0055	Clip	(1)				
17	-----	Planet Gear Set	(8)				
18	-----	Sun Gear	(1)				
19	10-20-0790	Warning Label	(1)				
20	-----	Carriage	(1)				
21	-----	Rear Housing	(1)				
22	-----	Ball Bearing	(1)				
23	-----	Cam Shaft	(1)				
24	-----	3/16" Dia. Steel Ball	(2)				
25	-----	Compression Spring	(1)				
26	-----	Washer	(1)				
27	-----	3.0mm Dia. Steel Ball	(29)				
28	14-29-0190	Gear Assembly	(1)				

**FIG. LUBRICATION**  
**(Type 'J' Grease, No. 49-08-4220):**

36 Coat inside grooves of Bushing (inside gearcase) with grease.

38 Lightly coat front washer surface of Anvil (38) with grease. Place a dab of grease in the Ball holes and in the hole in the back of the Anvil.

**No. 42-06-0301 3/8" SQUARE ANVIL ASSEMBLY**  
(Original Design)

- |    |            |  |     |
|----|------------|--|-----|
| 38 | 42-06-0301 | 3/8" Square Drive Anvil Assembly with Needle Bearing | (1) |
| 30 | 44-90-1000 | Hog Ring   | (1) |
| 39 | 34-40-0475 | Rubber Ring  | (1) |

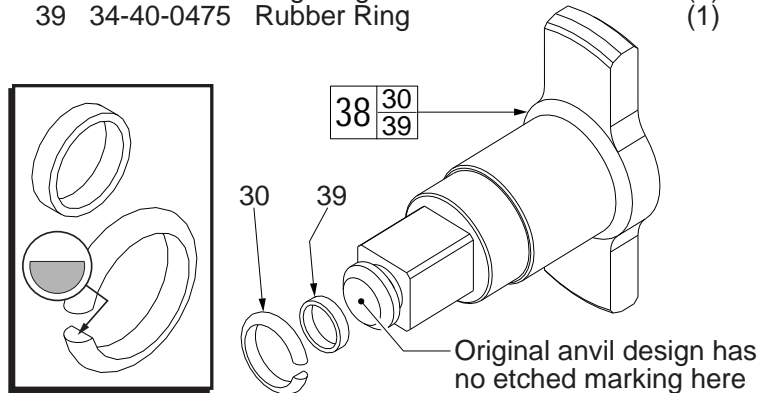

**FIG. 1**

**IMPORTANT!**  
*Hog Ring and O-Ring components of the 3/8" Square Anvil Assemblies for M12™ Impact Wrenches are unique and are NOT INTERCHANGEABLE between Anvil Assemblies*

Original Anvil Assembly 42-06-0301 (Fig. 1) uses Hog Ring 44-90-1000 and O-Ring 34-40-0475

Service Replacement Anvil Assembly 42-06-0310 (Fig. 2), identified by an etched symbol on the front face of the anvil, use Hog Ring 44-90-1050 and O-Ring 34-40-1885

If you have any questions please call  
After-Sales Service-Technical Support  
1.800.729.3878

**No. 42-06-0310 3/8" SQUARE ANVIL ASSEMBLY**  
(Service Replacement)

- |    |                   |  |     |
|----|-------------------|--|-----|
| 38 | <b>42-06-0310</b> | 3/8" Square Drive Anvil Assembly with Needle Bearing | (1) |
| 30 | 44-90-1050        | Hog Ring   | (1) |
| 39 | 34-40-1885        | Rubber Ring  | (1) |

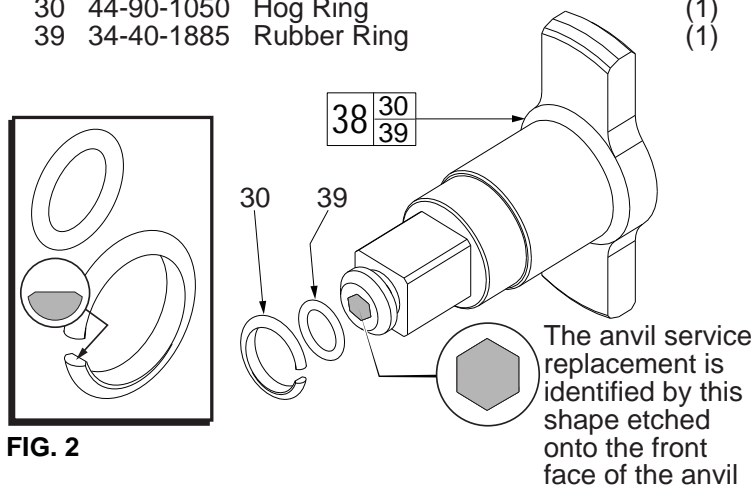

**FIG. 2**

AS AN AID TO REASSEMBLY, TAKE NOTICE OF WIRE ROUTING AND POSITION IN WIRE GUIDES AND TRAPS WHILE DISMANTLING TOOL

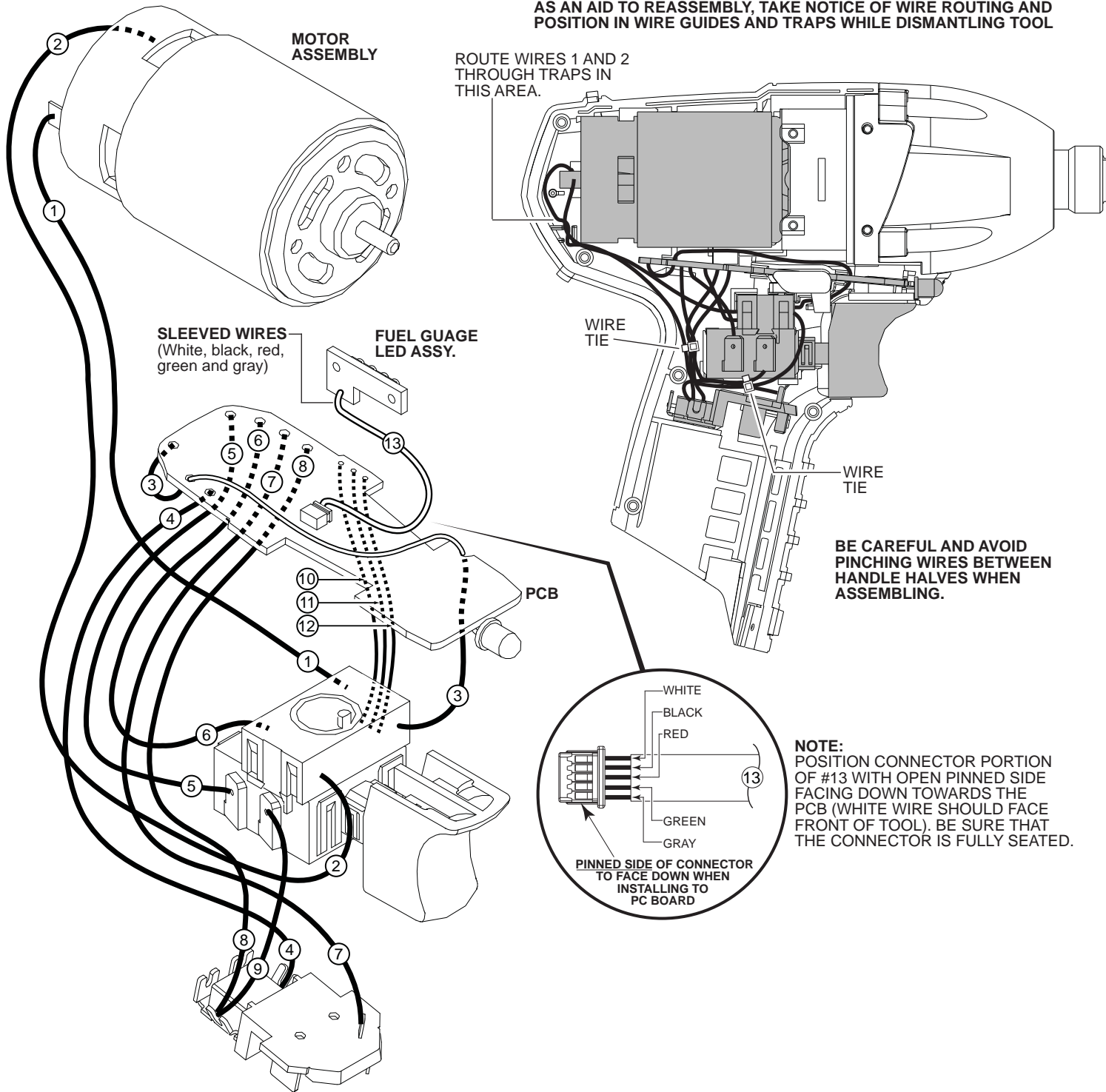

**WIRING SPECIFICATIONS**

Wire No.	Wire Color	Origin or Gauge	Length	Terminals, Connectors and 1 or 2 End Wire Preparation
1	Black	23-30-0090	-----	Component of the motor assembly.
2	Red	23-30-0090	-----	Component of the motor assembly.
3	White	23-66-1105	-----	Component of the electronics module assembly.
4	Black	23-66-1105	-----	Component of the electronics module assembly.
5	Black	23-66-1105	-----	Component of the electronics module assembly.
6	Red	23-66-1105	-----	Component of the electronics module assembly.
7	White	23-66-1105	-----	Component of the electronics module assembly.
8	Red	23-66-1105	-----	Component of the electronics module assembly.
9	Red	23-66-1105	-----	Component of the electronics module assembly.
10	Yellow	23-66-1105	-----	Component of the electronics module assembly.
11	Blue	23-66-1105	-----	Component of the electronics module assembly.
12	Black	23-66-1105	-----	Component of the electronics module assembly.
13	Sleeve	23-66-1105	-----	Component of the electronics module assy. / Fuel gauge LED.