



SERVICE PARTS LIST

BULLETIN NO.
54-26-2551

SPECIFY CATALOG NO. AND SERIAL NO. WHEN ORDERING PARTS		REVISED BULLETIN 54-26-2550	DATE June 2019
M12™ FUEL™ 1/4" Hex Impact Driver			
CATALOG NO.	2553-20	STARTING SERIAL NO.	J10B
		WIRING INSTRUCTION SEE PAGE 2	

EXAMPLE:
Component Parts (Small #)
Are Included When Ordering
The Assembly (Large #).

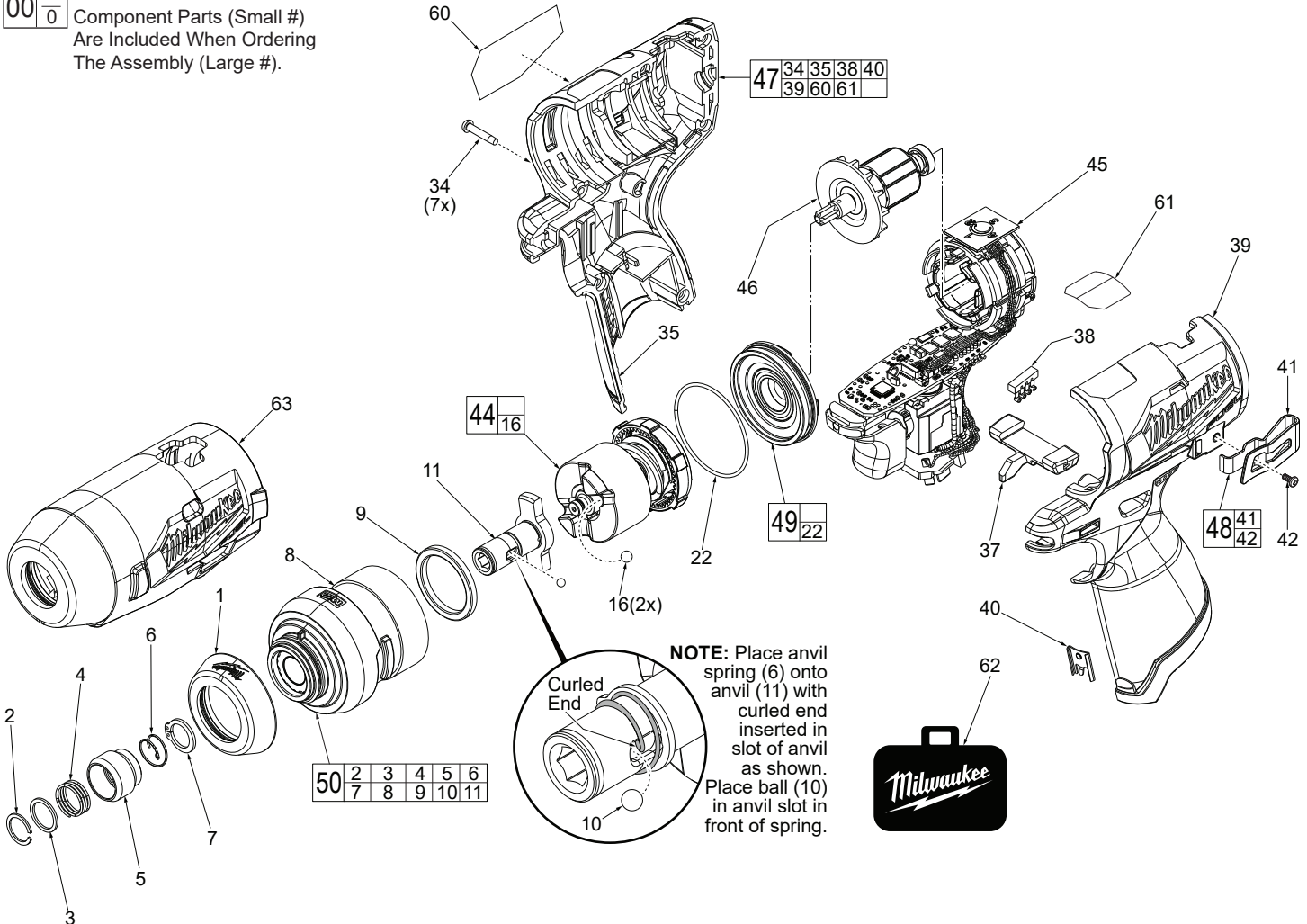
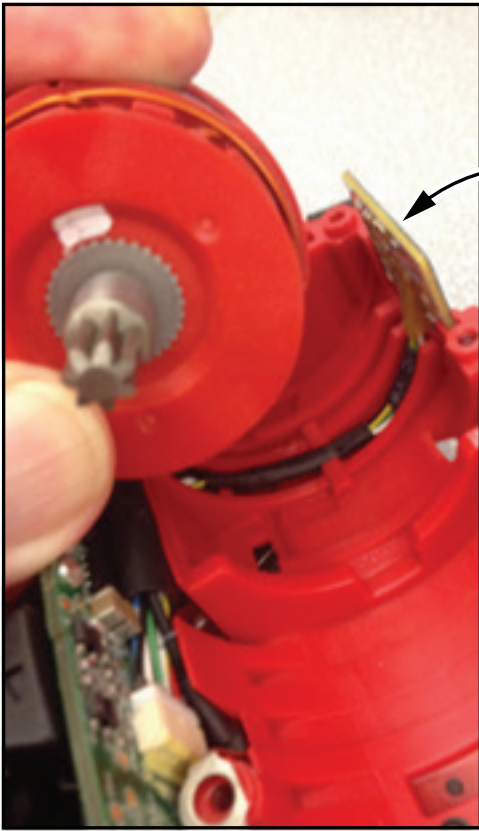

FIG.	PART NO.	DESCRIPTION OF PART	NO. REQ.
1	31-12-0053	Rubber Cap	(1)
2	34-60-0725	Retaining Ring	(1)
3	45-88-1880	Washer	(1)
4	40-50-1470	Spring	(1)
5	45-22-2643	Sleeve	(1)
6	40-50-0012	Anvil Spring	(1)
7	34-60-0002	Retaining Ring	(1)
★ 8	28-50-2554	Front Gear Case	(1)
9	45-88-2135	Nylon Ring	(1)
10	02-02-0170	3.5mm Steel Ball	(1)
11	42-06-2553	Anvil	(1)
16	02-02-0180	3/16" Steel Ball	(2)
★ 22	34-40-0303	O-Ring	(1)
34	06-82-6351	M3 x 16mm Pan Hd. ST T-10 Screw	(7)
35	-----	Housing Cover - Right Housing	(1)
37	45-24-2553	Forward/Reverse Shuttle	(1)
38	23-28-0012	Light Pipe	(1)
39	-----	Housing Support - Left Housing	(1)
40	42-70-0058	Housing Clip	(1)
41	-----	Belt Clip	(1)
42	05-88-1015	M2.5 x 6mm Pan Hd. Phillips Mach. Sc	(1)
★ 44	14-30-2554	Impacting Assembly with Ring Gear	(1)
45	14-20-2553	Electronics Assembly	(1)
46	16-01-1045	Rotor Assembly	(1)
47	31-44-2553	Housing Kit	(1)
48	42-70-0495	Belt Clip Kit	(1)
★ 49	44-66-0872	End Cap Assembly with Bearing	(1)

FIG.	PART NO.	DESCRIPTION OF PART	NO. REQ.
★ 50	14-30-2501	Gear Case Assembly	(1)
60	12-20-2553	Service Nameplate	(1)
61	10-20-2553	Spanish/French Warning Label	(1)
62	42-55-2553	Blow Molded Carrying Case	(1)
63	49-16-2553	Rubber Boot (Optional, Accessory)	(1)

When servicing, remove 90-95% of the existing grease prior to installing Type 'J'. Original grease maybe similar in color but not compatible with 'J'.

FIG.	LUBRICATION
	(Type 'J' Grease, No. 49-08-4220):
8	Coat anvil opening in the front of the gear case with grease.
10, 11	Lightly coat front washer surface of anvil (11) with grease, place a dab in the ball slot of anvil.
44, 49	Lightly coat the inside gear teeth of ring gear end cap (49) and the gear teeth of the planet gears of impacting assembly (44) with grease.
46	Coat pinion of rotor assembly (46) with grease.



Prior to installing Stator/Rotor Assemblies, place the Selector PCBA into the slotted Housing Support cavity. Press wires into channel as shown. Carefully place Stator/Rotor Assemblies into Housing Support, being sure all components are firmly and squarely seated.

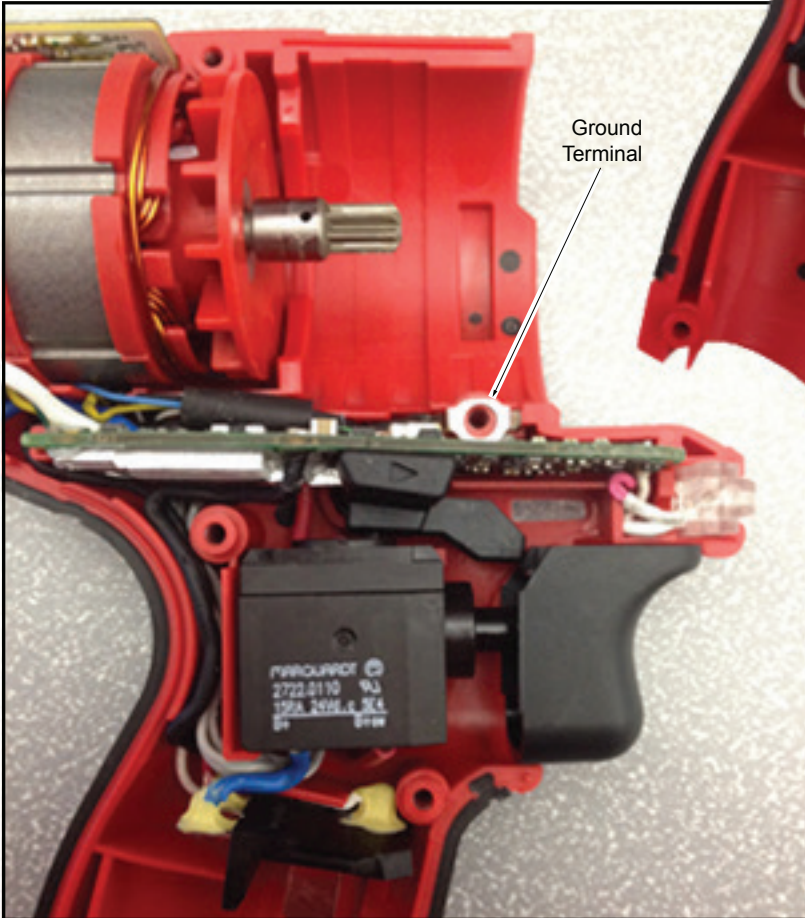
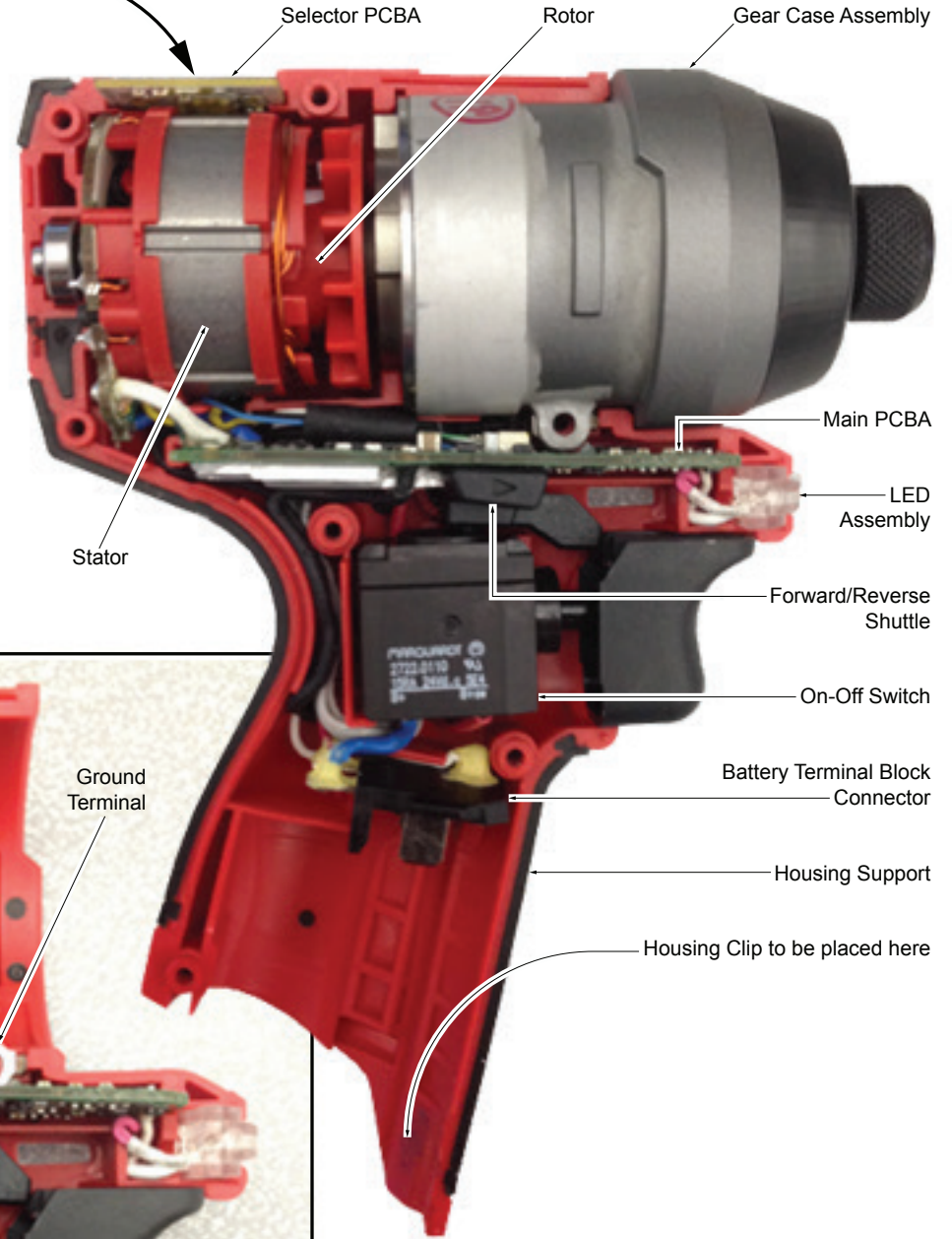

Prior to installing the Gear Case Assembly, be sure all elements of the Electronics Assembly are seated properly (Stator, Main PCBA, Selector PCBA, On-Off Switch, LED Assembly and Battery Terminal Block Connector). Be sure the Grounding Terminal is in place and that all wires are pressed down into all wire traps and channels. Check to assure that wires will not interfere with moving parts.

Prior to installing the Housing Cover, place Forward/Reverse Shuttle onto On-Off Switch and through Housing Support opening. Check to assure that wires will not be pinched.

Secure the Housing Cover to the Housing Support with seven M3 x 16mm ST T-10 Screws. Be sure to replace the Housing Clip at the bottom of the battery opening.