



SERVICE PARTS LIST

BULLETIN NO.
54-06-2663

SPECIFY CATALOG NO. AND SERIAL NO. WHEN ORDERING PARTS		REVISED BULLETIN 54-06-2662	DATE Apr. 2016
M18 FUEL™ COMPACT 1/2" DRIVER-DRILL			
CATALOG NO. 2603-20	STARTING SERIAL NO. D55D	WIRING INSTRUCTION	

EXAMPLE:
Component Parts (Small #) Are Included
When Ordering The Assembly (Large #).

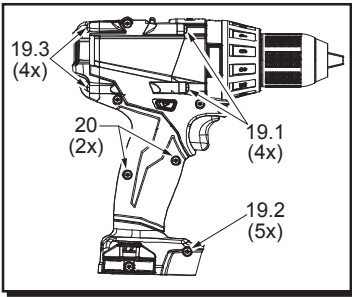

Apply Red Loctite® thread locking sealant or the equivalent to the threads of the gearcase spindle (3) before securing chuck to that spindle. Torque to 550-600in/lbs (45-50ft/lbs).

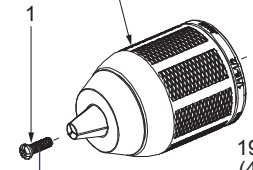

Apply Blue Loctite® thread locking sealant or the equivalent to the threads of the chuck screw (1) before securing chuck to the gearcase spindle. Torque to 90-100in/lbs (7-8ft/lbs).

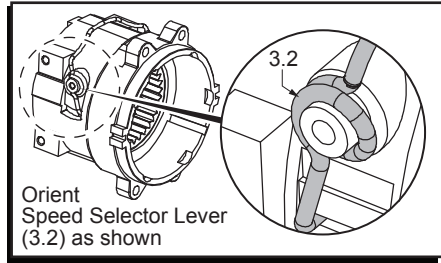
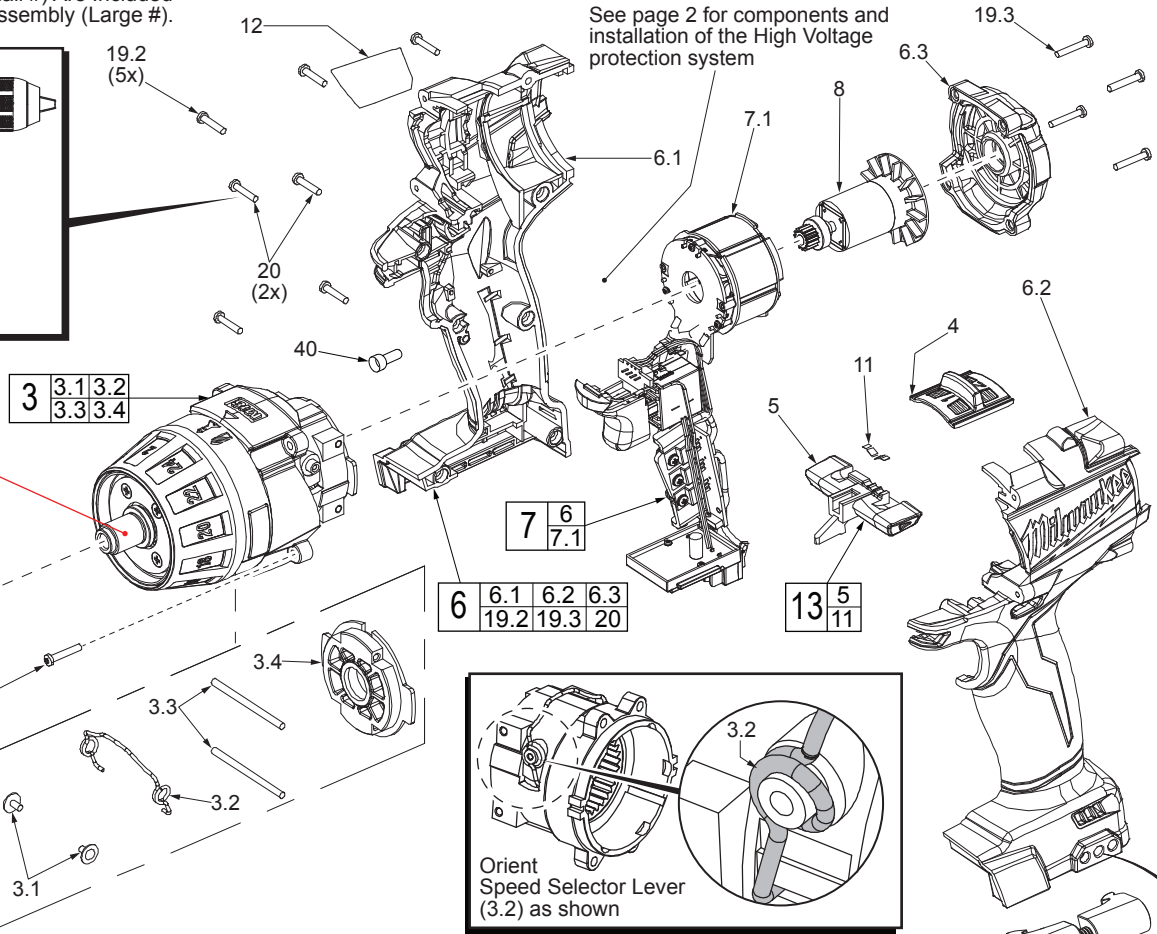
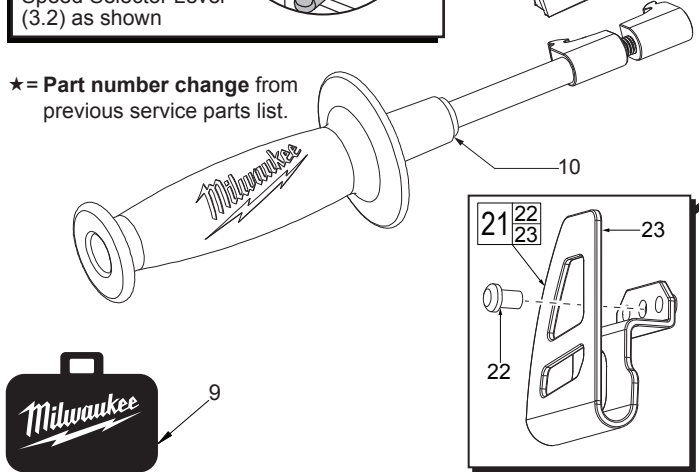

FIG.	PART NO.	DESCRIPTION OF PART	NO. REQ.
1	05-88-1500	M6 x 1.0 LH Chuck Screw w/ locking patch	(1)
2	42-66-0200	1/2" Keyless Chuck	(1)
3	14-29-2603	Gearcase Assembly	(1)
3.1	05-81-0542	M2.3 x 4.5mm ST Screw	(2)
3.2	44-10-2603	Speed Selector Lever	(1)
3.3	-----	2.3 x 34 Pin	(2)
3.4	-----	Motor Mounting Plate	(1)
4	45-24-2603	Speed Selector Button	(1)
★ 5	42-42-2803	Forward / Reverse Shuttle	(1)
★ 6	31-44-2803	Housing Kit	(1)
6.1	-----	Right Housing Halve	(1)
6.2	-----	Left Housing Halve	(1)
6.3	-----	Rear Cap	(1)
★ 7	14-20-2804	Housing / Electronics Kit	(1)
7.1	-----	Motor / Switch / PCBA Assembly	(1)
8	16-07-2603	Service Armature	(1)
9	42-55-2604	Blow Molded Carrying Case	(1)
10	42-62-0526	Auxiliary Side Handle Assembly	(1)
11	40-50-1135	Shuttle Spring	(1)
★ 12	12-20-2603	Service Nameplate	(1)
★ 13	42-42-2804	Forward / Reverse Shuttle Kit	(1)
19.1	06-82-6350	M3 x 16mm T-10 ST Screw (Gearcase)	(4)
19.2	06-82-6350	M3 x 16mm T-10 ST Screw (Handle Halves)	(5)
19.3	06-82-6350	M3 x 16mm T-10 ST Screw (Rear Cap)	(4)
20	06-82-1080	M3 x 14mm T-10 ST Screw (Handle Halves)	(2)
21	42-70-2653	Belt Clip Assembly	(1)
22	06-82-0130	6-32 x 5/16" Pan Hd. T-15 Machine Screw	(1)
23	-----	Belt Clip	(1)
30	23-94-2125	220mm Wire Assy. with Terminal (High Voltage Protection, See Page 2)	(1)
40	22-56-0150	Closed End Connector	(1)

★ = Part number change from previous service parts list.



SCREW TORQUE SPECIFICATION CHART				
FIG.	PART NO.	DESCRIPTION	SEATING TORQUE (IN-LBS) (FT-LBS)	
1	05-88-1500	Chuck Screw	90-100	7-8
2	42-66-0200	Chuck	550-600	45-50
3.1	05-81-0542	Speed Selector Lever Screw	3.5±1	
19.1	06-82-6350	Gearcase Assembly Scr	7.0±2.5	
19.2	06-82-6350	Right Housing Halve Scr (Qty. 5)	7.0±2.5	
19.3	06-82-6350	Rear Cap Screw	4.0±1	
20	06-82-1080	Right Housing Halve Scr (Qty. 2)	7.5±2.5	

MILWAUKEE ELECTRIC TOOL CORPORATION
13135 W. Lisbon Road, Brookfield, WI 53005
Drwg. 2