

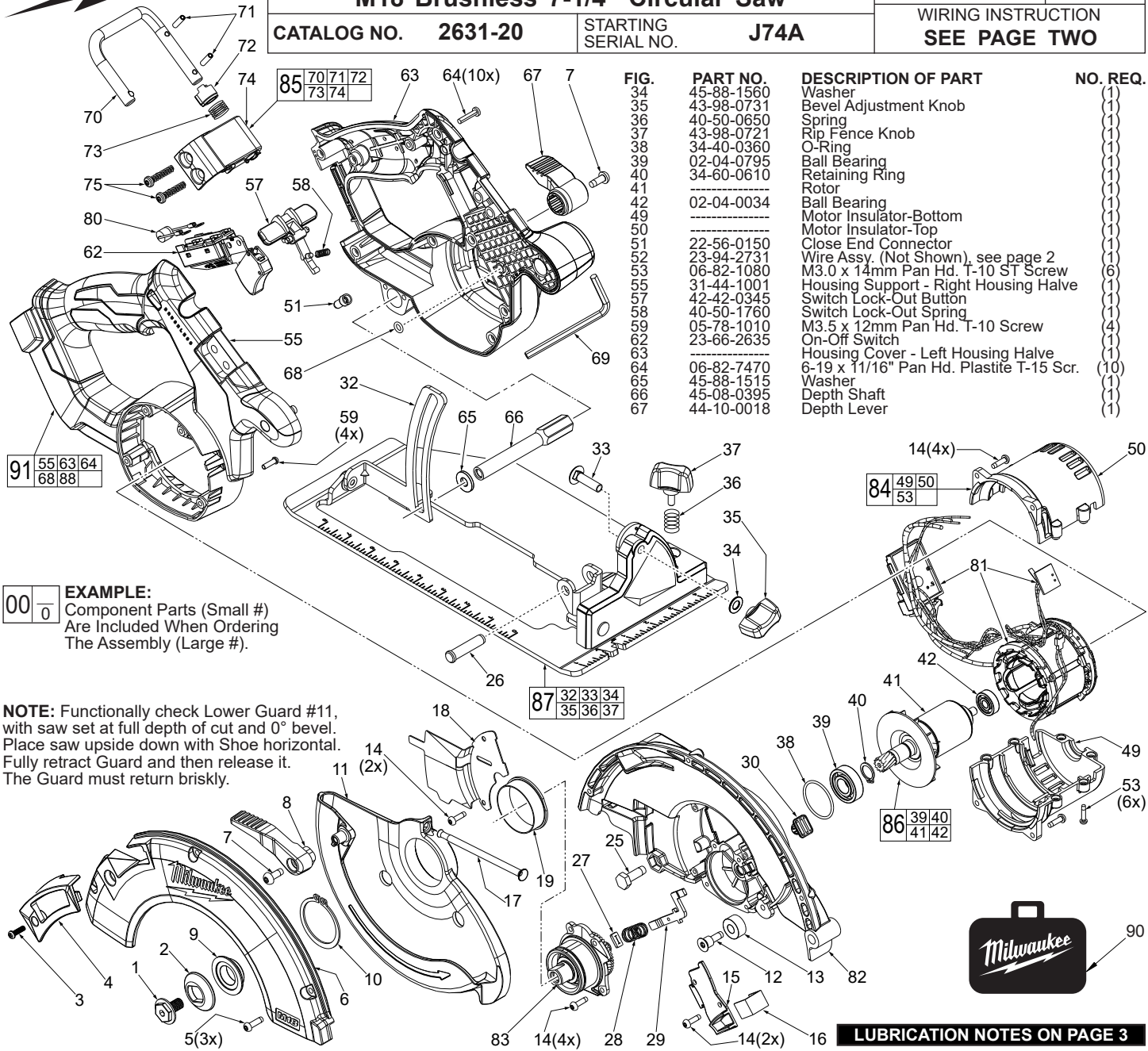

SERVICE PARTS LIST

BULLETIN NO.
54-40-2635

SPECIFY CATALOG NO. AND SERIAL NO. WHEN ORDERING PARTS		REVISED BULLETIN	DATE
M18 Brushless 7-1/4" Circular Saw			June 2018
CATALOG NO.	2631-20	STARTING SERIAL NO.	J74A
		WIRING INSTRUCTION SEE PAGE TWO	



EXAMPLE:
Component Parts (Small #)
Are Included When Ordering
The Assembly (Large #).

NOTE: Functionally check Lower Guard #11,
with saw set at full depth of cut and 0° bevel.
Place saw upside down with Shoe horizontal.
Fully retract Guard and then release it.
The Guard must return briskly.

LUBRICATION NOTES ON PAGE 3

FIG.	PART NO.	DESCRIPTION OF PART	NO. REQ.	FIG.	PART NO.	DESCRIPTION OF PART	NO. REQ.
1	06-75-1012	Left Hand Blade Screw	(1)	68	34-40-4480	O-Ring	(1)
2	43-34-0795	Outer Blade Flange	(1)	69	49-96-0600	3/16" Hex Key	(1)
3	05-78-1005	M3.5 x 12mm Pan Hd. Phillips Screw	(1)	70		Saw Hook Bar	(1)
4	49-90-4001	Dust Chute	(1)	71	44-60-0585	Coiled Spring Pin	(2)
5	05-78-5316	M4 x 14mm Pan Hd. Tapt. T-20 Screw	(3)	72	45-22-1005	Detent Sleeve	(1)
6	28-20-2001	Upper Guard Cover	(1)	73	40-50-0985	Saw Hook Spring	(1)
7	06-82-5314	10-24 x 1/2" Pan Hd. Tapt. T-25 Screw	(1)	74		Saw Hook Housing	(1)
8	44-10-1008	Lower Guard Lever	(1)	75	06-82-0052	M6 x 32mm Pan Hd. T-25 PT Screw	(2)
9	43-34-0790	Inner Blade Flange	(1)	80	23-38-2840	Diode Assembly	(1)
10	34-60-0860	Retaining Ring	(1)	81	14-20-5001	Electronic Assembly	(1)
11	28-41-1001	Lower Guard	(1)	82	28-14-9005	Upper Guard Gear Case Assy. w/ Needle Bearing	(1)
12	45-04-0485	10-32 x 13/16" Bumper Screw	(1)	83	38-50-0160	Output Shaft Assembly	(1)
13	42-38-0224	Rubber Bumper	(1)	84	23-16-9001	Motor Insulator Assembly	(1)
14	06-82-5285	6-32 x 1/2" Pan Hd. Taptite T-15 Screw	(12)	85	14-36-0001	Saw Hook Assembly	(1)
15	31-15-0265	Spindle/LED Cover	(1)	86	23-40-6001	Rotor Assembly	(1)
16	22-06-2732	LED Assembly	(1)	87	14-74-1001	Shoe Assembly	(1)
17	40-50-0045	Lower Guard Spring	(1)	88	12-20-8450	Service Nameplate (Not Shown)	(1)
18	44-66-0398	Retaining Plate	(1)	89	49-22-2731	Rip Fence (Not Shown)	(1)
19	45-14-0015	Plastic Sleeve	(1)	90	50-55-3550	Contractors Bag	(1)
25	06-75-5860	1/4-20 x 3/4" Hex Hd. Screw	(1)	91	14-38-3001	Housing Assembly	(1)
26	44-60-0741	Pivot Pin	(1)	92	10-20-0359	Warning Label (Not Shown)	(1)
27	45-06-0720	Felt Seal	(1)				
28	40-50-8046	Spindle Lock Spring	(1)				
29	44-20-0653	Spindle Lock Plate	(1)				
30	42-42-1030	Spindle Lock Button	(1)				
32		Shoe	(1)				
33	06-10-4001	M6 x 28mm Carriage Bolt	(1)				

WIRING OF THE ON-OFF SWITCH

- Orient the diode with the grey stripe to the right as shown. Place ring terminals of diode assembly onto the switch prior to installing red wires #1 and white wire #2.
- Place ring terminal of red wire #1 (from the top PCBA position) at the bottom left position of switch over diode terminal. Be sure wire is routed over the diode assembly.
- Place ring terminal of white wire #2 (from the battery connector block) at the bottom right position of the switch over diode terminal. Be sure wire is routed over the diode assembly.
- Secure diode assembly and wires #1 and #2 with switch screws.
- Route white wire #3 (from the battery connector block) between red wires #1 and #2, and under the diode assembly, to the upper right position of the switch. Secure the ring terminal with a switch screw, as shown.
- Route yellow wire #4 (from the battery connector block) between red wires #1 and #2, and under the diode assembly, to the upper left position of the switch. Secure the ring terminal with a switch screw, as shown.

● = WIRE TRAPS or GUIDES

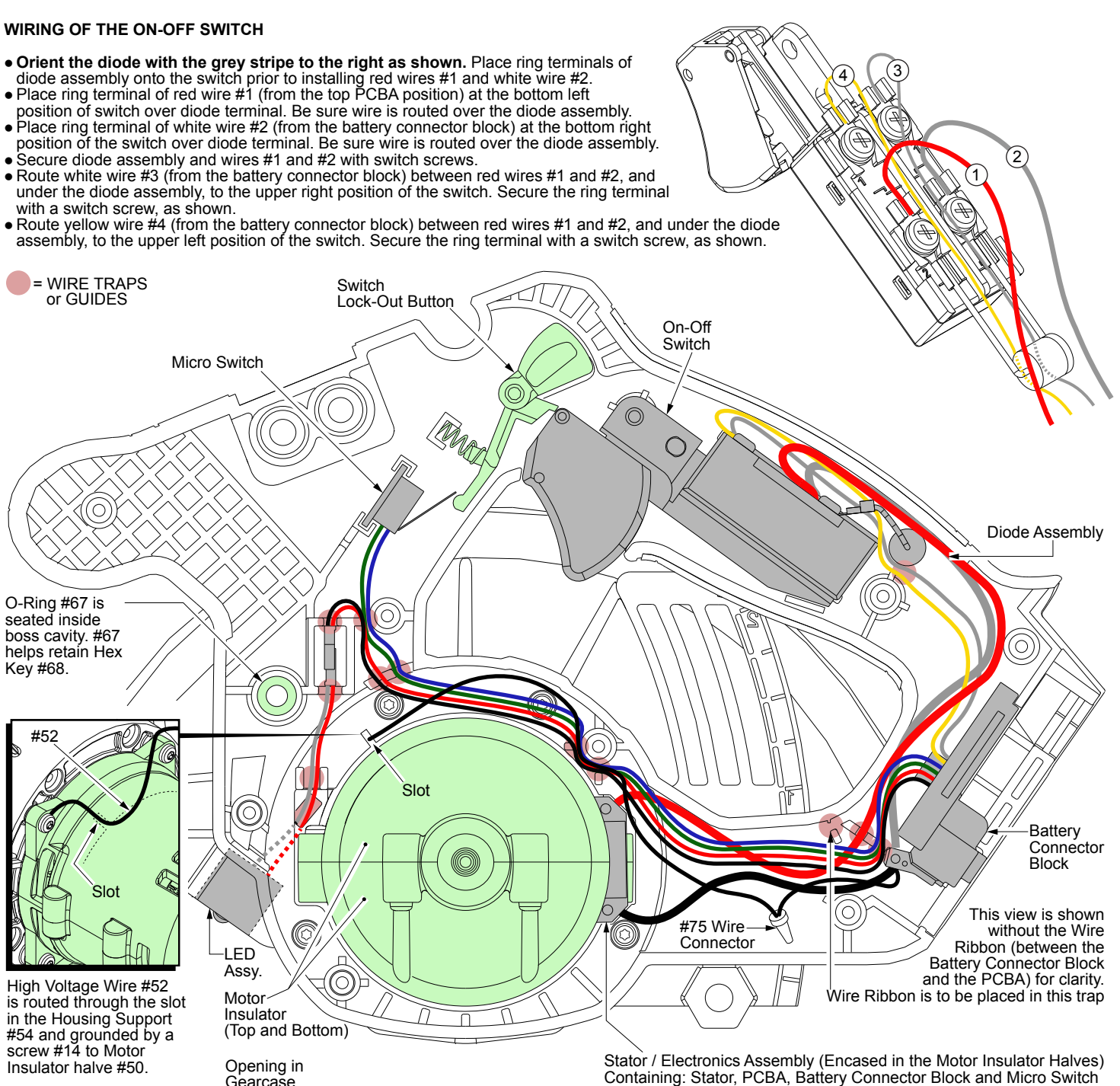

Figure 1: Shown without the Spindle Lock Assembly for clarity.

- Insert the LED Assembly into cavity of Upper Guard Gearcase as shown.
- Route male connector and wires through the openings in the Gearcase and Housing Support.
- Be sure that LED wires are in Gearcase trap and pull taut.

Figure 2:

- Connect the male connector of the LED Assembly with the Female connector from Battery Connector Block.

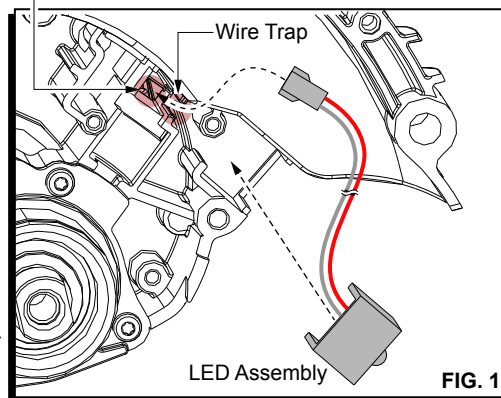

FIG. 2

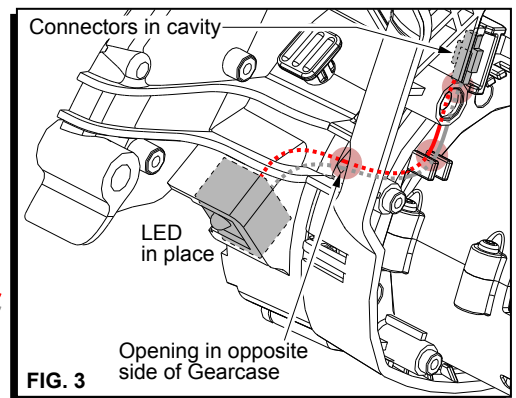
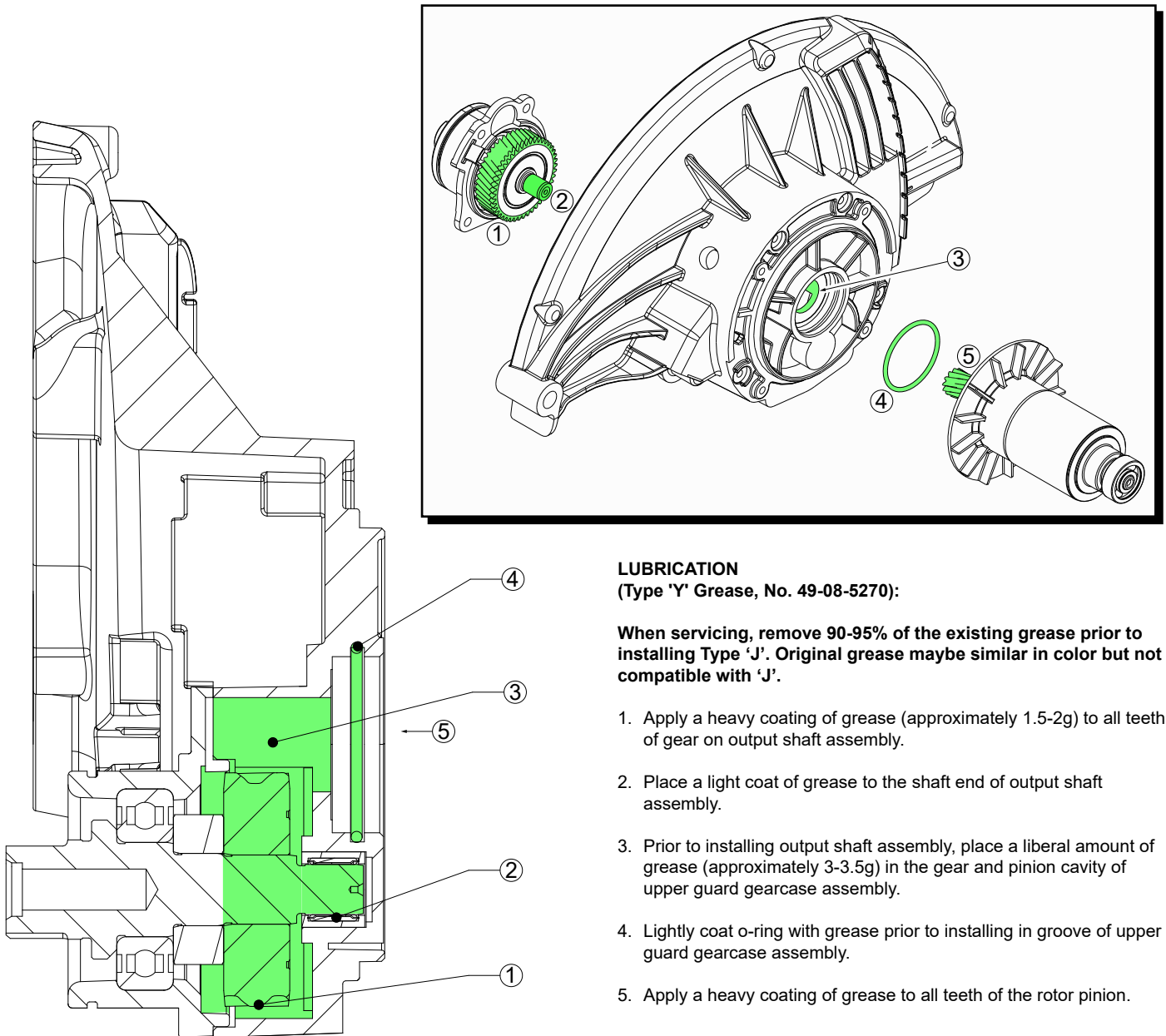

Figure 3:

- Place the joined connectors in the Housing Support cavity and route all wires in the appropriate wire traps as shown in main illustration.



LUBRICATION
(Type 'Y' Grease, No. 49-08-5270):

When servicing, remove 90-95% of the existing grease prior to installing Type 'J'. Original grease maybe similar in color but not compatible with 'J'.

1. Apply a heavy coating of grease (approximately 1.5-2g) to all teeth of gear on output shaft assembly.
2. Place a light coat of grease to the shaft end of output shaft assembly.
3. Prior to installing output shaft assembly, place a liberal amount of grease (approximately 3-3.5g) in the gear and pinion cavity of upper guard gearcase assembly.
4. Lightly coat o-ring with grease prior to installing in groove of upper guard gearcase assembly.
5. Apply a heavy coating of grease to all teeth of the rotor pinion.

