



# SERVICE PARTS LIST

**BULLETIN NO.**  
**54-26-2682**

SPECIFY CATALOG NO. AND SERIAL NO. WHEN ORDERING PARTS		REVISED BULLETIN	DATE
<b>CORDLESS 18V 3/4" SQUARE IMPACT WRENCH</b>		54-26-2681	Apr. 2019
<b>CATALOG NO.</b>	<b>2664-20</b>	<b>STARTING SERIAL NO.</b>	<b>B81C</b>
		<b>WIRING INSTRUCTION</b> <b>See Page 3</b>	

**EXAMPLE:**  
Component Parts (Small #)  
Are Included When Ordering  
The Assembly (Large #).

★ = Part number change from  
previous service parts list.

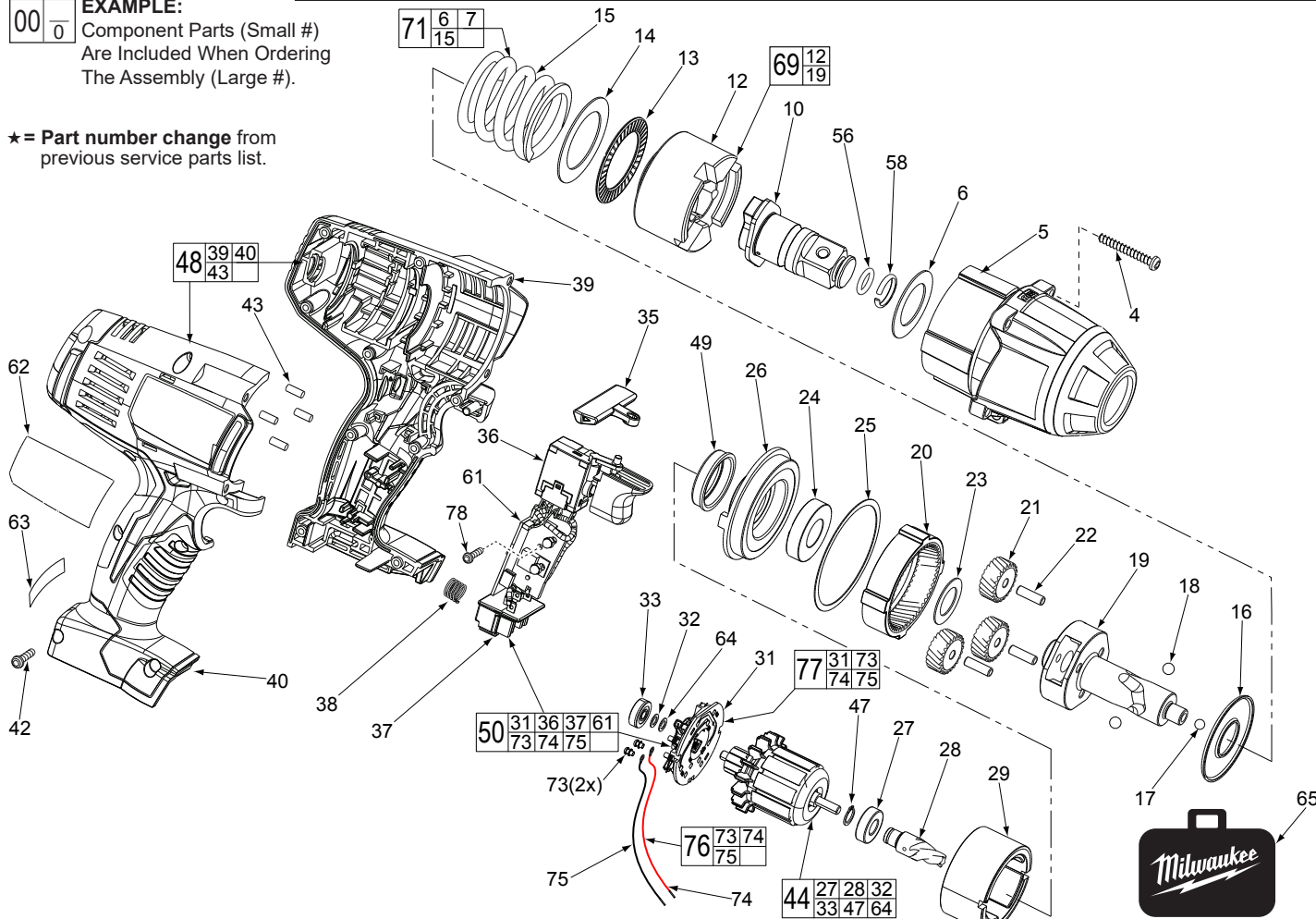

FIG.	PART NO.	DESCRIPTION OF PART	NO.REQ.
4	05-88-5988	M5 X 35mm Pan Hd. Slit. T-20 Screw	(4)
★ 5	14-30-0966	Front Housing Assy. w/ Bushing and O-Rings	(1)
★ 6	45-88-1825	Washer	(1)
★ 10	42-06-0691	3/4" Anvil	(1)
12	-----	Hammer	(1)
13	02-80-0200	Thrust Bearing	(1)
14	45-88-1006	Washer	(1)
15	40-50-0755	Compression Spring	(1)
16	45-88-1650	Washer	(1)
17	02-02-7010	7/32" Ball	(1)
18	02-02-0250	1/4" Ball	(2)
★ 19	-----	Camshaft	(1)
20	32-65-0260	Ring Gear	(1)
21	32-62-0500	Planet Gear	(3)
22	44-60-1960	Pin	(3)
23	45-88-1655	Washer	(1)
24	02-04-0375	Ball Bearing	(1)
25	34-40-0290	Seal Ring	(1)
26	44-66-0895	Motor Mount Plate	(1)
27	-----	Ball Bearing - Front	(1)
28	-----	Pinion	(1)
29	18-01-3025	Service Field Assembly	(1)
31	-----	Brush Card	(1)
32	-----	Washer	(1)
33	-----	Ball Bearing - Rear	(1)
35	45-24-0570	Forward / Reverse Shuttle	(1)
36	-----	Switch	(1)
37	-----	Connector Block	(1)
38	40-50-1090	Compression Spring	(1)
39	-----	Handle - Left	(1)
40	-----	Handle - Right	(1)
42	06-82-0995	M4 x 16mm Pan Hd. T-20 Screw	(9)
43	45-30-0255	Rubber Slug	(4)
44	16-01-3030	Armature Assembly	(1)
47	-----	Retaining Ring	(1)
48	31-44-0696	Handle Set	(1)

FIG.	PART NO.	DESCRIPTION OF PART	NO.REQ.
49	45-22-0380	Rubber Cap	(1)
50	22-56-1451	Switch/Connector Block Assembly	(1)
56	34-40-1210	O-Ring	(1)
58	44-90-4540	C-Ring	(1)
61	-----	PCBA	(1)
62	12-20-2670	Service Nameplate Kit	(1)
63	10-20-2695	Warning Label	(1)
64	-----	Washer	(1)
65	42-55-2665	Carrying Case, Optional	(1)
★ 69	14-46-2071	Camshaft/Hammer Service Kit	(1)
71	14-46-0755	Spring/Washer/Bearing Kit	(1)
★ 73	05-88-0920	M3 x 0.5 x 5mm PH T10 WasherScr.	(2)
74	-----	Leadwire Assembly - Red	(1)
75	-----	Leadwire Assembly - Black	(1)
76	14-46-2395	Leadwire/Screw/Washer Kit	(1)
77	14-46-2024	Brush Card Assembly	(1)
78	06-82-2395	M2.6 x 10 Pan Hd. T-8 Screw	(1)

**FIG. LUBRICATION**  
**(Type 'Z' Grease, No. 49-08-7655):**

20,21 Lightly coat the I.D. of the Ring Gear (20) and the center of the three Planet Gears (21) with grease.

19 Place a dab of grease in ball grooves of the Cam Shaft (19).

10 Lightly coat the front washer surface of Anvil (10) with grease, place a dab in the Ball hole on the backside of Anvil.

3 Coat outside grooves of Bushing (3) with grease.

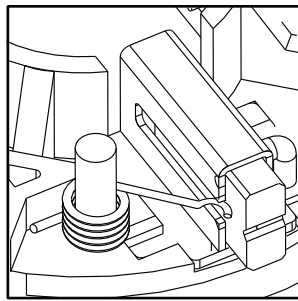
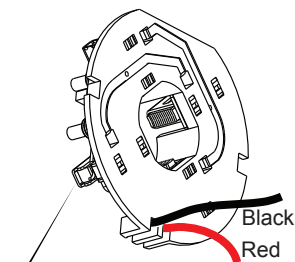

**NOTE:**

As an aid to prevent damage to the armature commutator or the brushes when removing and installing the armature assembly, it is recommended to pull the carbon brushes partially back into the brush tube. The carbon brushes will be held in place with the brush spring moving from the rear of the brush to the side of the brush.

In the unlikely event that the spring pops off follow the instructions below.

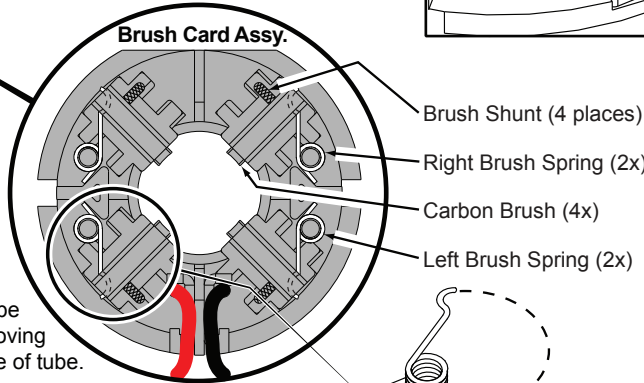

Be sure carbon brush is in brush tube with brush shunt moving freely in side groove of tube.

Place brush spring over post with short leg positioned downward as shown. Be sure spring is completely down with short leg trapped against 'Y' shaped wall on brush card.

While holding spring in place, bring the long leg of spring over the brush tube and through rear opening of tube. Position rounded hook of spring in groove on back of carbon brush. Be sure to check for free movement between carbon brush, brush shunt and brush spring.

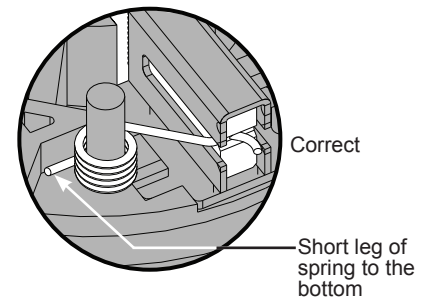
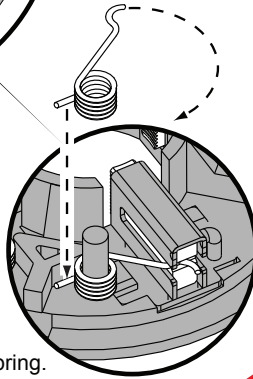

Short leg of spring to the bottom

AS AN AID TO REASSEMBLY, TAKE NOTICE OF WIRE ROUTING AND POSITION IN WIRE GUIDES AND TRAPS WHILE DISMANTLING TOOL.

BE SURE THAT ALL COMPONENTS OF THE ELECTRONICS KIT ARE SEATED FIRMLY AND SQUARELY IN THE HANDLE RECESSES.

AVOID PINCHED WIRES, BE SURE THAT ALL WIRES AND SLEEVES ARE PRESSED COMPLETELY DOWN IN WIRE GUIDES AND TRAPS.

PRIOR TO INSTALLING THE HANDLE COVER ONTO THE HANDLE SUPPORT, BE SURE THAT THERE ARE NO INTERFERENCES.

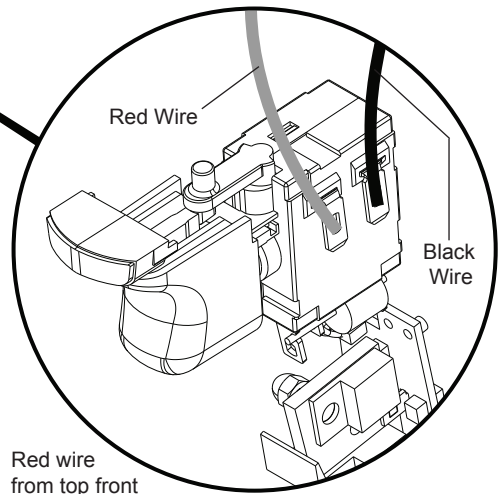
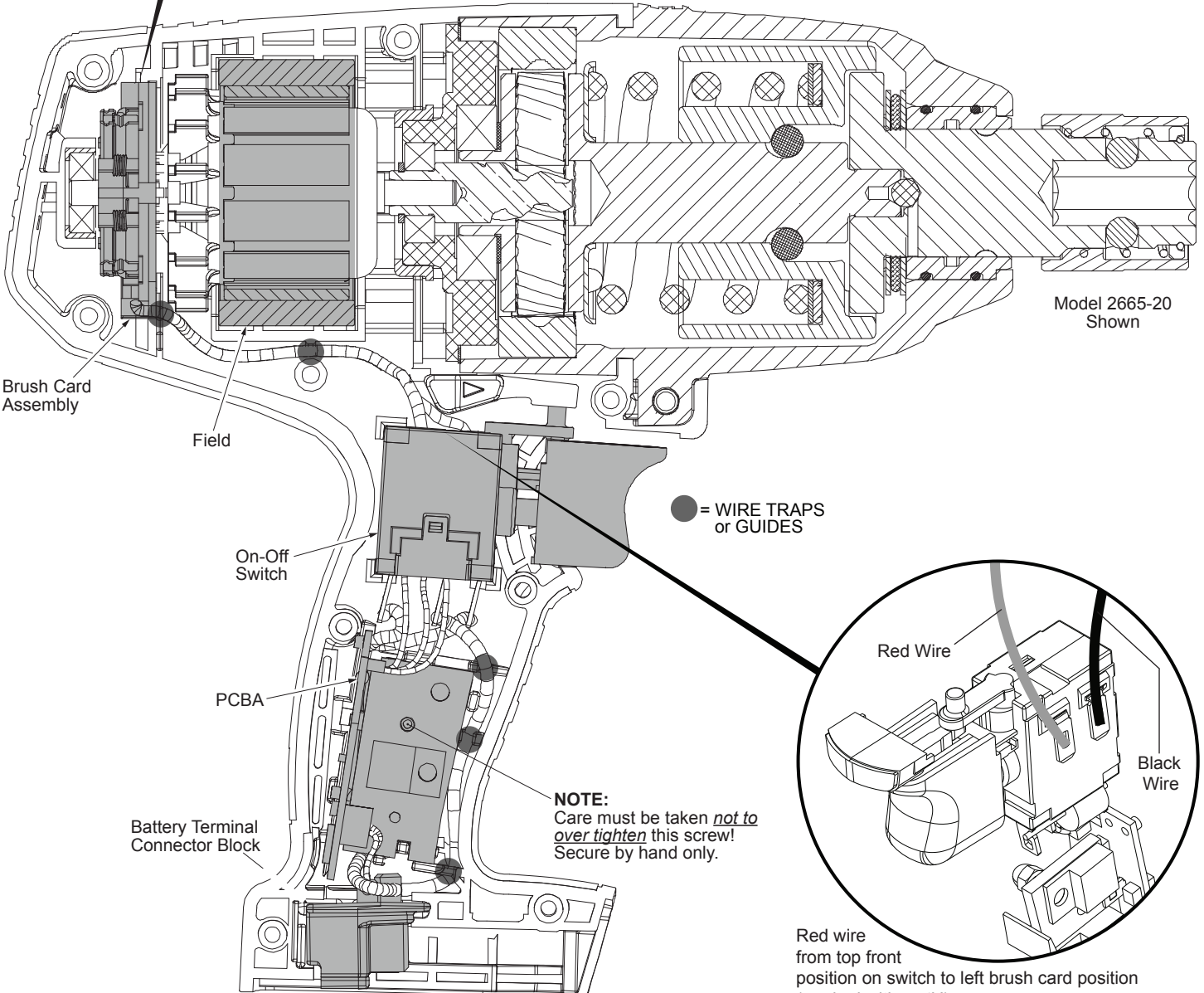
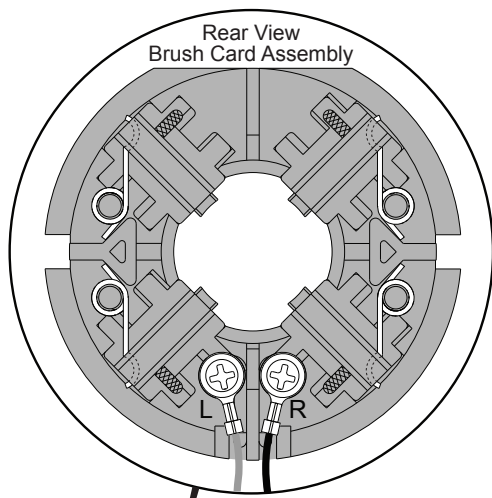

Red wire from top front position on switch to left brush card position (marked with an 'L').

Black wire from top rear position on switch to right brush card position (marked with an 'R').