



SERVICE PARTS LIST

BULLETIN NO.
54-32-0010

SPECIFY CATALOG NO. AND SERIAL NO. WHEN ORDERING PARTS		REVISED BULLETIN	DATE
M18 FUEL™ 15mm Random Orbital Polisher			Oct. 2021
CATALOG NO. 2684-20	STARTING SERIAL NO. M08A	WIRING INSTRUCTION SEE REVERSE SIDE	

EXAMPLE:
00 0 Component Parts (Small #)
Are Included When Ordering
The Assembly (Large #).

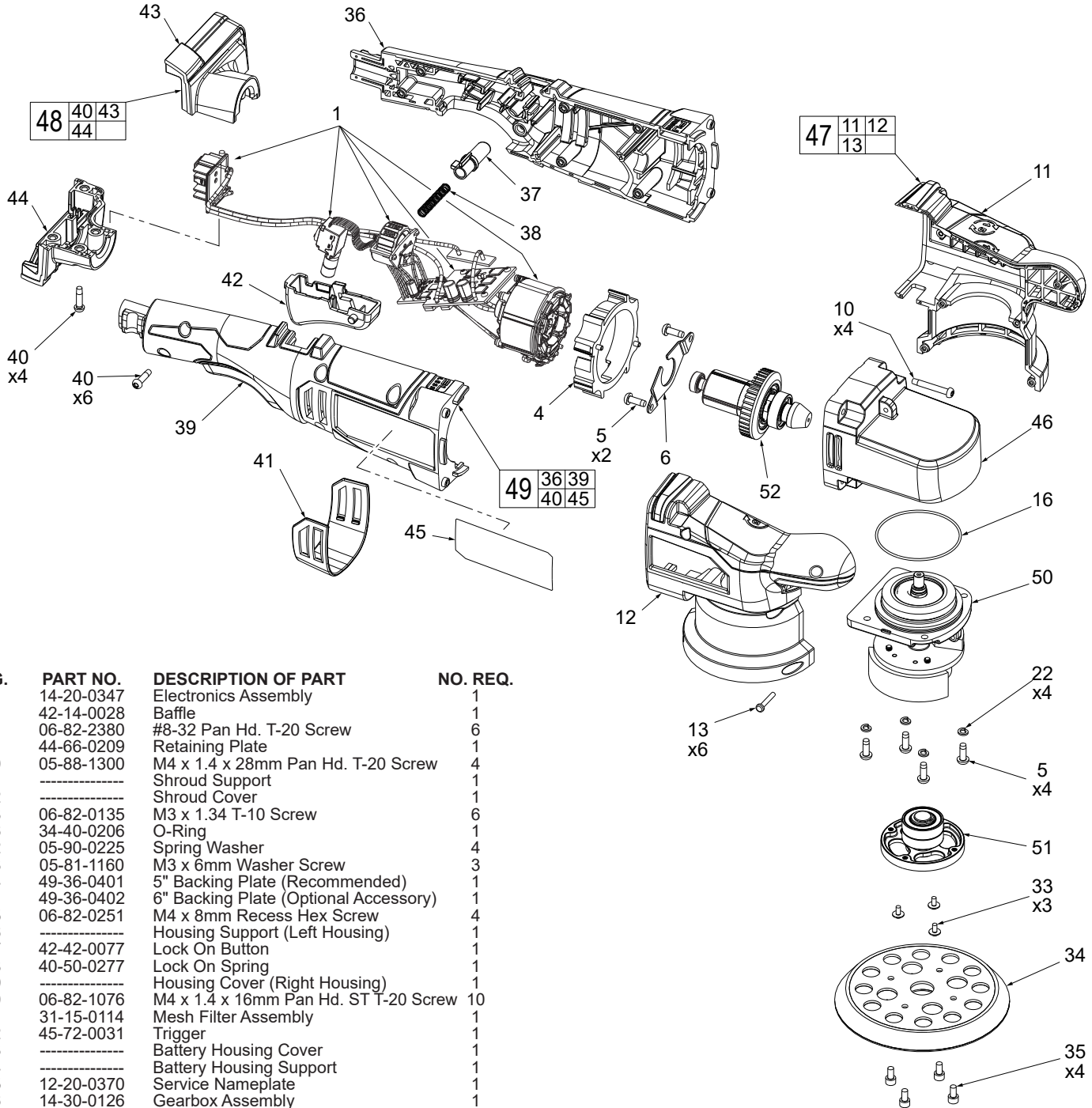
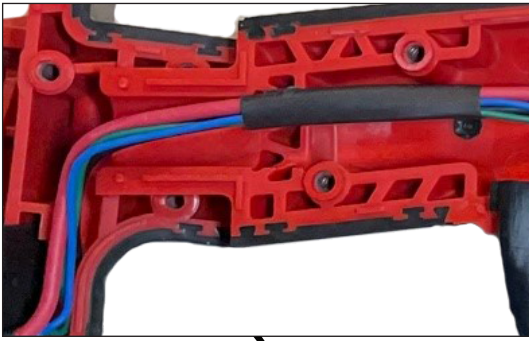

FIG.	PART NO.	DESCRIPTION OF PART	NO. REQ.
1	14-20-0347	Electronics Assembly	1
4	42-14-0028	Baffle	1
5	06-82-2380	#8-32 Pan Hd. T-20 Screw	6
6	44-66-0209	Retaining Plate	1
10	05-88-1300	M4 x 1.4 x 28mm Pan Hd. T-20 Screw	4
11	-----	Shroud Support	1
12	-----	Shroud Cover	1
13	06-82-0135	M3 x 1.34 T-10 Screw	6
16	34-40-0206	O-Ring	1
22	05-90-0225	Spring Washer	4
33	05-81-1160	M3 x 6mm Washer Screw	3
34	49-36-0401	5" Backing Plate (Recommended)	1
	49-36-0402	6" Backing Plate (Optional Accessory)	1
35	06-82-0251	M4 x 8mm Recess Hex Screw	4
36	-----	Housing Support (Left Housing)	1
37	42-42-0077	Lock On Button	1
38	40-50-0277	Lock On Spring	1
39	-----	Housing Cover (Right Housing)	1
40	06-82-1076	M4 x 1.4 x 16mm Pan Hd. ST T-20 Screw	10
41	31-15-0114	Mesh Filter Assembly	1
42	45-72-0031	Trigger	1
43	-----	Battery Housing Cover	1
44	-----	Battery Housing Support	1
45	12-20-0370	Service Nameplate	1
46	14-30-0126	Gearbox Assembly	1
47	31-44-0292	Pommel Assembly	1
48	31-44-0291	Battery Housing Assembly	1
49	31-44-0290	Housing Assembly	1
50	14-73-0233	Output Assembly	1
51	14-73-0234	Receiver Assembly	1
52	16-01-0054	Rotor Assembly	1



Carefully place/route ribbon cable in traps as shown.

Route all wires and wire groupings through wire traps as shown. Be sure to push wires, sleeved wire groupings and ribbon cables firmly below wire trap openings.

Avoid bending wires sharply from switch.

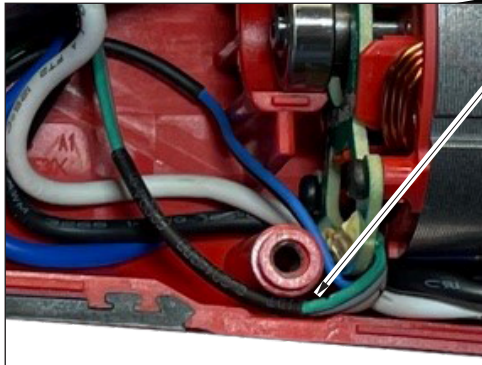
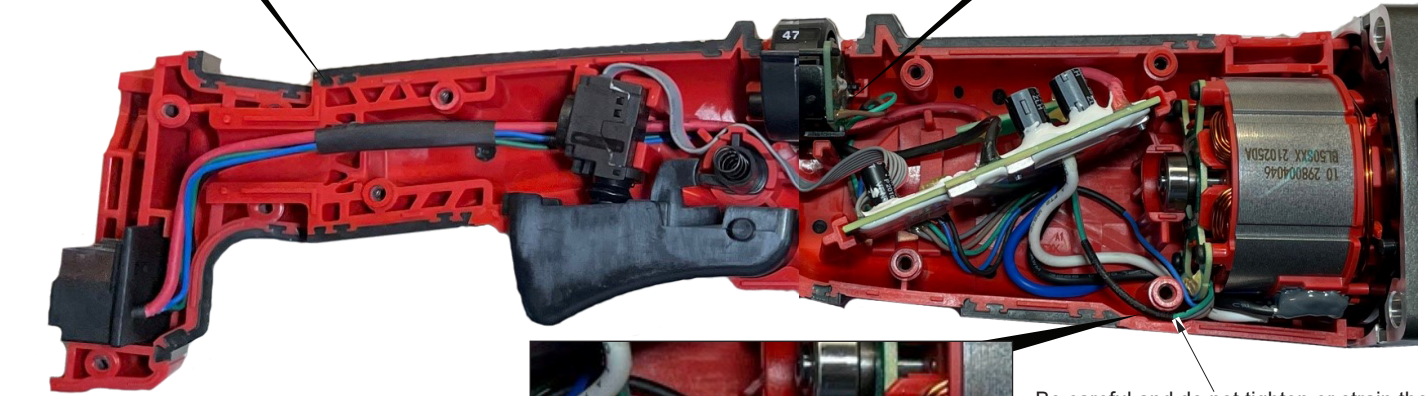
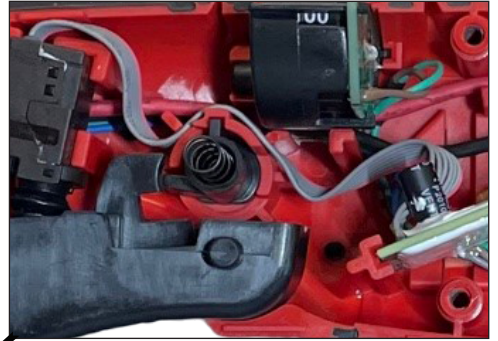

Be careful and do not tighten or strain the wires in this area.

- As an aid to reassembly, take notice of wire routing and position in wire guides and traps while dismantling tool.
- Be sure that all components of the electronics kit are seated firmly and squarely in the handle recesses.
- Avoid pinched wires, be sure that all wires and sleeves are pressed completely down in wire guides and traps.
- Prior to installing the handle cover onto the handle support, be sure that there are no interferences.

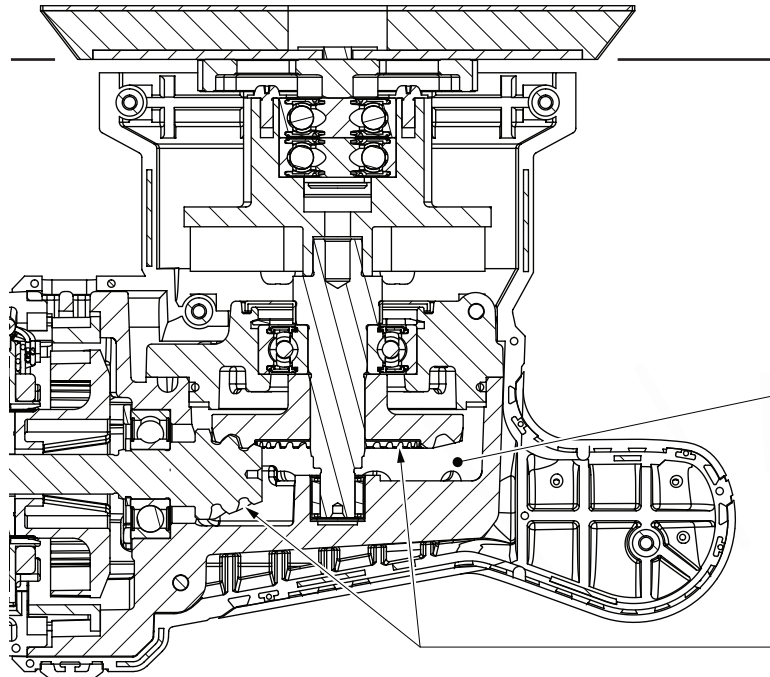

SCREW TORQUE SPECIFICATIONS

FIG.	PART NO.	WHERE USED	SEAT TORQUE	
			(KG/CM)	(IN/LBS)
5	06-82-2380	Gear Case	22±2.0	19±2.0
10	05-88-1300	Gear Case	20±2.0	17±2.0
13	06-82-0135	Shroud Cover	10.0±1.0	8.5±1.0
24	-----	Lower Counterweight	15±1.5	13±1.5
28	-----	Upper Counterweight	20±2.0	17±2.0
33	05-81-1160	Receiver Plate	10±1.0	8.5±1.0
35	06-82-0251	Backing Plate	25±2.5	21.5±2.5
40	06-82-1076	Foot Support	14±1.5	12±1.5

When servicing, remove 90-95% of the existing grease prior to installing Type 'Y'. Original grease may be similar in color but not compatible with 'Y'.

LUBRICATION NOTES:

Use Type 'Y' Grease, No. 49-06-5270 (6 ounce tube)
No. 49-06-5275 (14 ounce tub)

Place 20±2.0 grams of grease in the Gear Case cavity, around the Pinion and above and below the Bevel Gear.

Place a heavy coating of grease to the teeth of the Bevel Gear and to the teeth of the Pinion Gear on the Rotor Assembly #52.