



SERVICE PARTS LIST

BULLETIN NO.
55-26-2751

SPECIFY CATALOG NO. AND SERIAL NO. WHEN ORDERING PARTS		REVISED BULLETIN	DATE
M18 FUEL™ 7/16" QUICK CONNECT IMPACT WRENCH		55-26-2750	Nov. 2015
CATALOG NO. 2765-059	STARTING SERIAL NO. F81B	WIRING INSTRUCTION See Page 2	

EXAMPLE:
Component Parts (Small #) Are Included
When Ordering The Assembly (Large #).

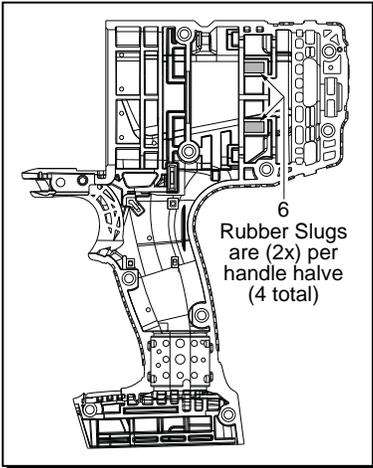

**14-46-0475
Tool Hanger
Assy.**

NOTE:
DO NOT substitute screws #34 here.

★ = Part number change from previous service parts list.

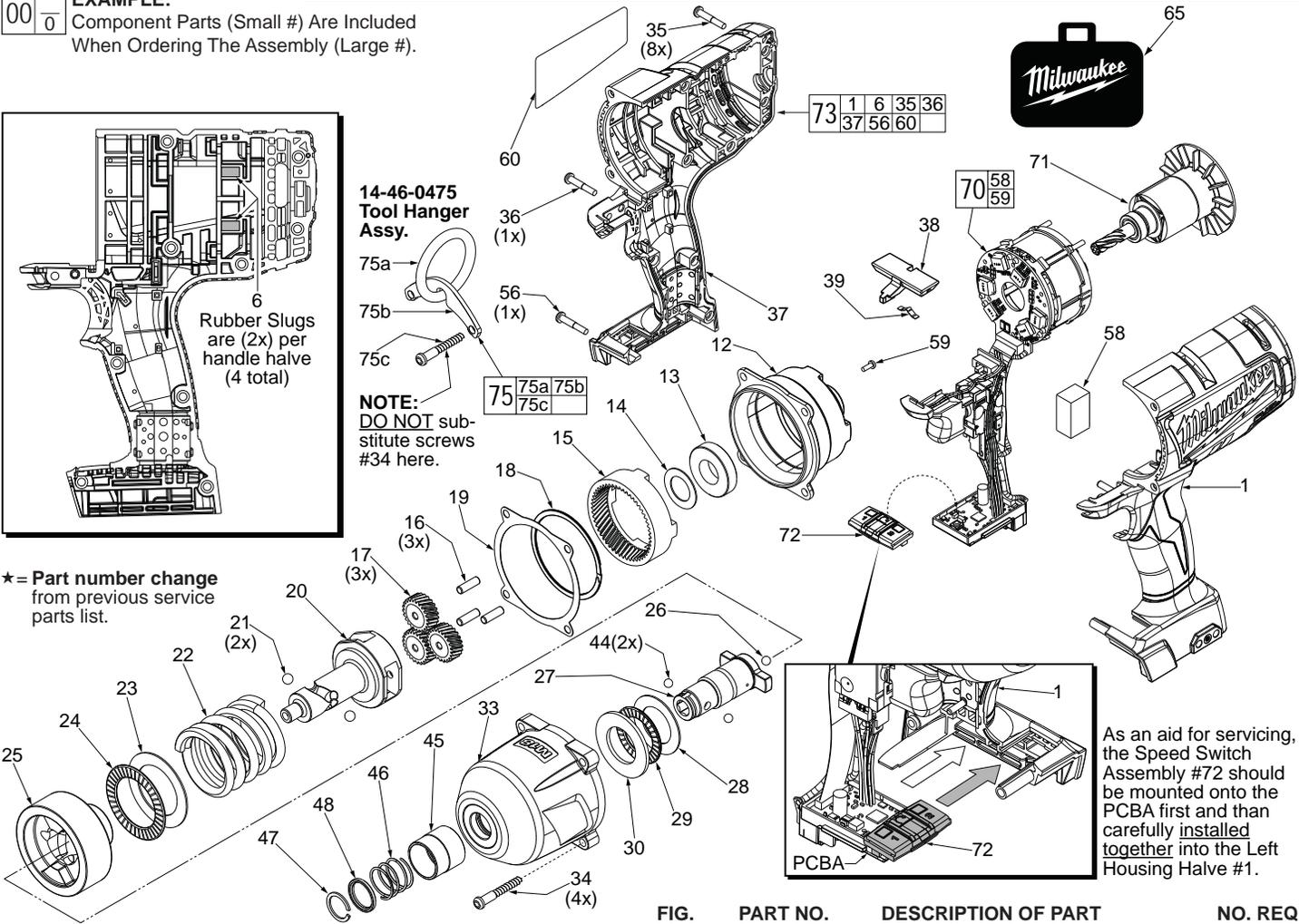
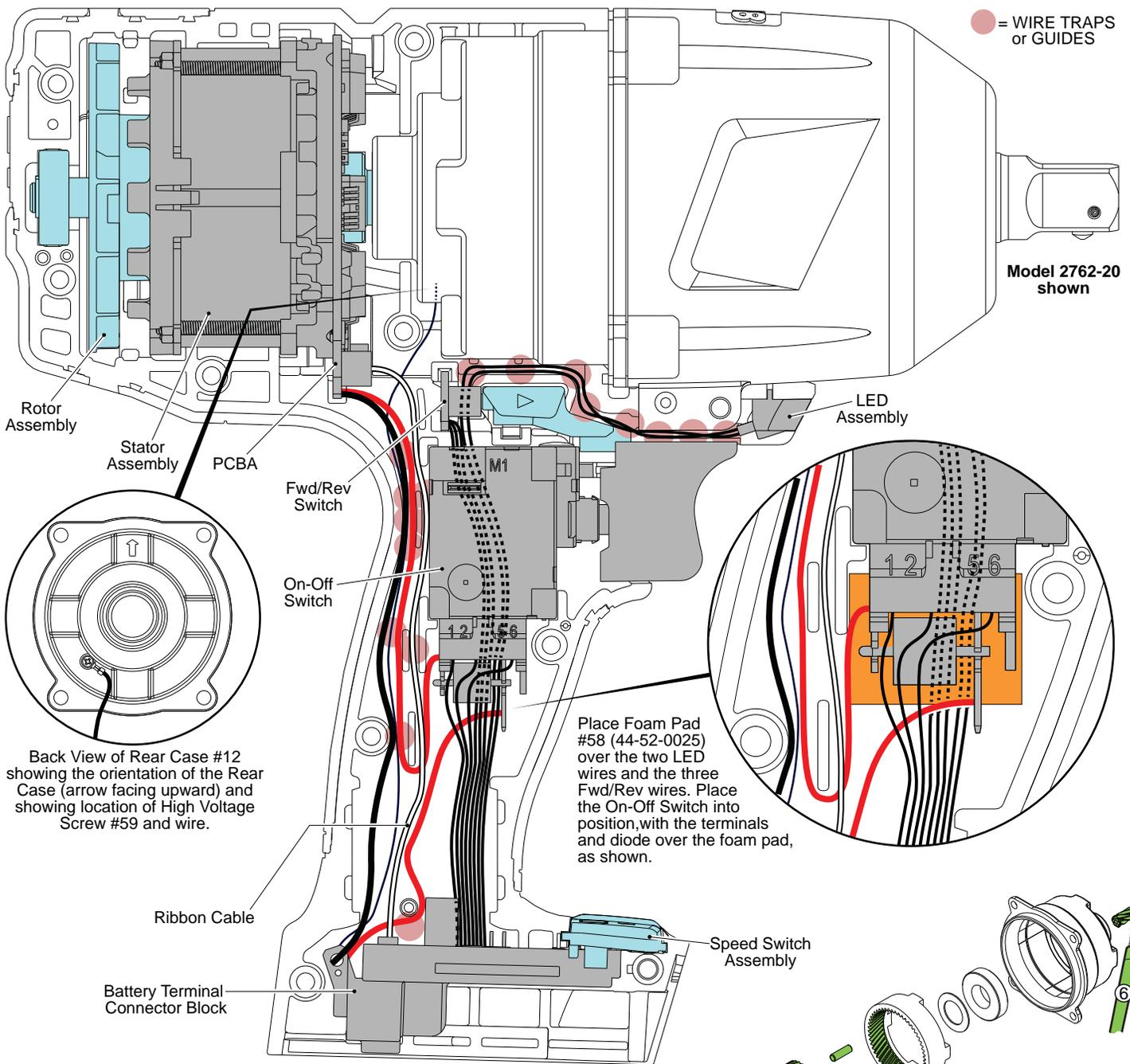

FIG.	PART NO.	DESCRIPTION OF PART	NO. REQ.
1	-----	Handle Support (Housing Halve-Left) w/ metal pin	1
6	45-30-0255	Rubber Slug	4
12	44-66-0417	Rear Case	1
13	02-04-0375	Ball Bearing	1
14	45-88-1655	Thrust Washer	1
15	32-65-0025	Ring Gear	1
16	44-60-1960	Planet Pin	3
17	32-62-0500	Planet Gear	3
18	30-40-0052	Retaining Ring	1
19	43-44-0065	Gasket	1
20	36-10-0020	Camshaft	1
21	02-02-0250	1/4" Steel Ball	2
22	40-50-0955	Hammer Spring	1
23	45-88-1006	Thrust Washer	1
24	02-80-0200	Hammer Thrust Bearing	1
25	43-81-0110	Hammer	1
26	02-02-7010	7/32" Steel Ball	1
27	42-06-0065	7/16" Hex Anvil	1
28	45-88-1875	Thrust Washer	1
29	02-80-3256	Thrust Bearing	1
30	45-88-1620	Thrust Washer	1
33	14-30-0120	Front Housing Assembly with Bushing	1
34	06-82-2210	50 x 40mm Pan Hd. PT T-20 Screw	4
35	06-82-0995	M4 x 16mm Pan Hd. Plastite T-20 Screw	8
36	06-82-2230	M4 x 22mm Pan Hd. Plastite T-20 Screw	1
37	-----	Handle Cover (Housing Halve Right)	1
38	45-24-0130	Forward / Reverse Shuttle	1
39	40-50-0027	Shuttle Spring	1

FIG.	PART NO.	DESCRIPTION OF PART	NO. REQ.
44	02-02-0250	Steel Ball	2
45	42-76-0185	Sleeve	1
46	40-50-0365	Sleeve Spring	1
47	34-60-0050	Retaining Ring	1
48	44-90-0020	Washer	1
56	06-81-5383	M4 x 35mm Pan Hd. Plastite T-20 Screw	1
58	44-52-0025	Foam Pad	1
59	06-82-0165	High Voltage Screw	1
60	-----	Service Nameplate	1
65	48-55-3560	Contractor Bag	1
★70	14-20-0093	Electronics Assembly Consisting of On-Off Switch, Stator, PCBA, Forward/Reverse Switch, LED, Battery Terminal Connector Block, Foam Pad and High Voltage Screw	1
71	16-01-0105	Rotor Assembly	1
72	45-24-0110	Speed Switch Assembly	1
73	31-44-0868	Housing Assembly	1

SCREW TORQUE SPECIFICATIONS				
FIG.	PART NO.	WHERE USED	SEAT TORQUE	
			(KG/CM)	(IN/LBS)
34	06-82-2210	Front Housing Assy.	36	31
35	06-82-0995	Housing Assembly	12.5	11
36	06-82-2230	Housing Assembly	8.5	7
56	06-82-2240	Housing Assembly	12.5	11
59	06-82-0165	High Voltage Screw		



● LUBRICATION NOTES:

Type 'J' Grease

No. 49-08-4220, 1 lb. can

A total of approx. 11 grams (.4 oz) will be used.

Prior to reinstalling, clean gear assemblies with a clean, dry cloth. Lightly coat all parts highlighted here with 'J' grease. Apply a greater amount of grease to all internal and external gear teeth.

