



SERVICE PARTS LIST

BULLETIN NO.
54-00-2871

SPECIFY CATALOG NO. AND SERIAL NO. WHEN ORDERING PARTS		REVISED BULLETIN	DATE
M18™ FUEL™ Sectional Sewer Machine			Feb. 2020
CAT. NO.	2871-20	STARTING SERIAL	K89A
		WIRING INSTRUCTION	

SEWER MACHINE FRAME

PAGE 2

SEWER MACHINE EXTERNALS

PAGE 3

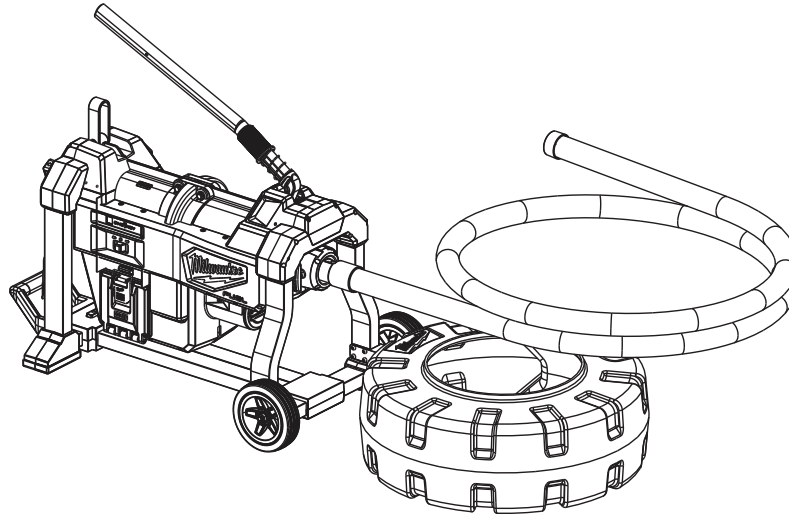

**Due to the electronics in this tool,
service can only be performed at Milwaukee Authorized Repair Centers:**

MILWAUKEE TOOL Central Repair

1401 Sycamore Avenue • Greenwood, MS 38930-7277

Please send your tool directly to this location for service.

Or

Via e-Service at: www.milwaukeetool.com/e-service
questions, please call 1.800.SAWDUST (1.800.729.3878)

Or

Visit www.milwaukeetool.com to find your closest
Milwaukee authorized Hydraulic repair center

Or

Return it to a MILWAUKEE *factory* Service Center location, freight prepaid and insured.
A copy of the proof of purchase should be included with the return product.

If you have questions please contact Milwaukee Product Service at:

Product Technical Support via phone at: 262.783.8642

Or

Via email at: METProductSupport@milwaukeetool.com

Disassembly is not recommended and could void the warranty.

SEWER MACHINE FRAME

EXAMPLE:
Component Parts (Small #)
Are Included When Ordering
The Assembly (Large #).



Service Videos are available to aid in repair and maintenance of M18™ FUEL™ Sectional Sewer Machine Tools.

Note: Cowlings and Housings need to be removed to access parts.

● = Items shaded in grey are included in 42-38-0027 kit with hardware.

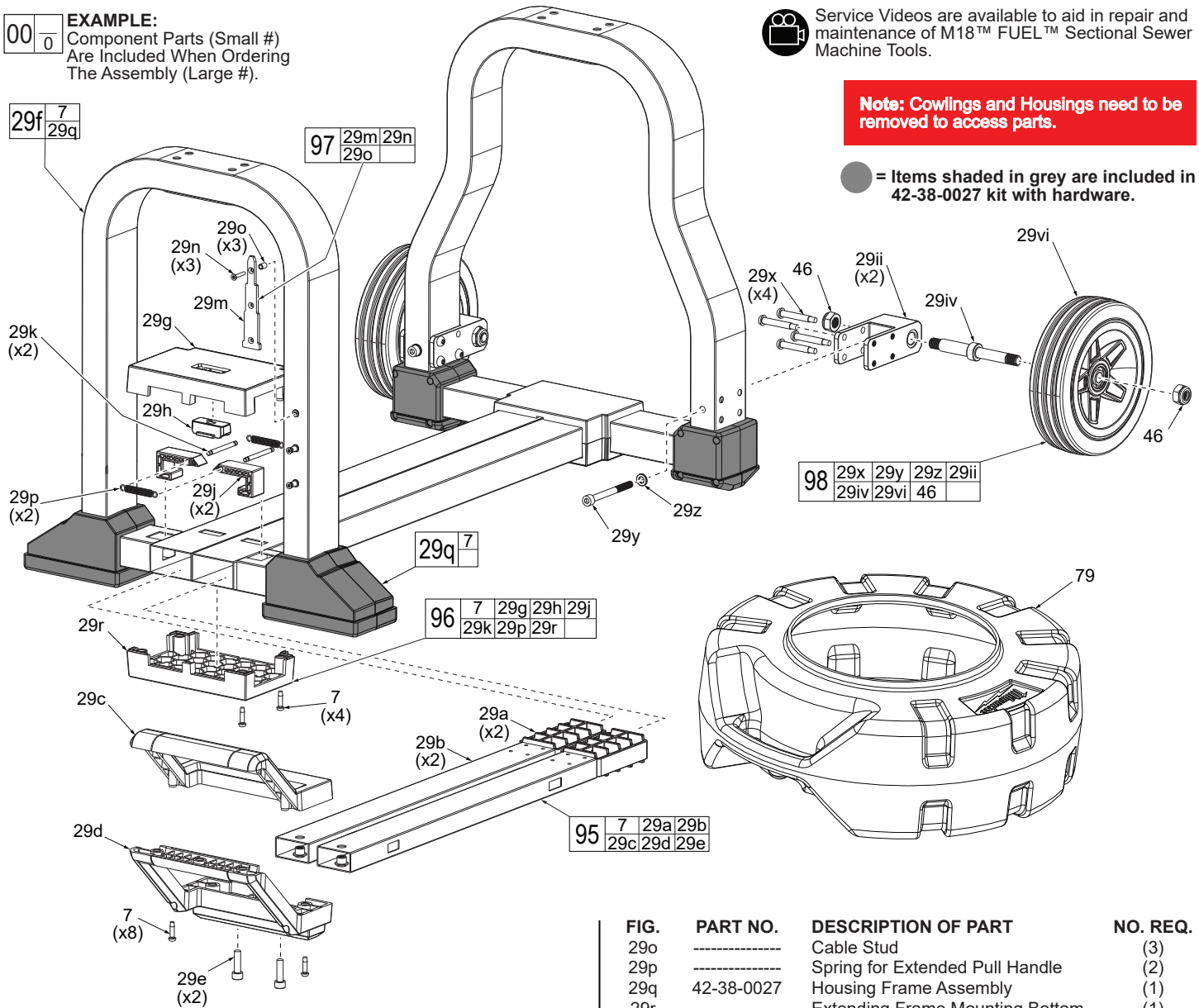

FIG.	PART NO.	DESCRIPTION OF PART	NO. REQ.
7	06-82-4003	M4 x 18mm St. T-20 Screw	(16)
29a	-----	Extending Frame Pilot Block	(2)
29b	-----	Extending Frame Tube	(2)
29c	-----	Extending Frame Handle Cover	(1)
29d	-----	Extending Frame Handle Support	(1)
29e	05-74-0015	M6 x 1mm T-30 Mach. Screw	(2)
29f	43-40-0037	Welded Frame Assembly	(1)
29g	-----	Extending Frame Mounting Top	(1)
29h	-----	Extending Frame Lock Button	(1)
29j	-----	Extending Frame Lever	(2)
29k	-----	Pin for Extended Frame Lever	(2)
29m	-----	Cable Hook	(1)
29n	-----	M3 x 0.5 T-10 Mach. Screw	(3)

FIG.	PART NO.	DESCRIPTION OF PART	NO. REQ.
29o	-----	Cable Stud	(3)
29p	-----	Spring for Extended Pull Handle	(2)
29q	42-38-0027	Housing Frame Assembly	(1)
29r	-----	Extending Frame Mounting Bottom	(1)
29x	05-78-0101	M5 x 40mm T-25 Mach. Screw	(8)
29y	05-74-0058	M6 x 65mm CH Hex Recess Mach. Screw	(1)
29z	-----	Flat Washer	(2)
29ii	-----	Wheel Mounting	(2)
29iv	-----	Wheel Shaft	(2)
29vi	-----	Wheel w/ Bearings	(2)
29vii	-----	M3 x 11mm ST Screw	(8)
46	-----	Lock Nut	(4)
79	47-53-2871	Cable Drum Assembly (Accessory)	(1)
95	14-46-0156	Extending Handle Kit	(1)
96	43-74-0022	Extending Handle Lock Kit	(1)
97	44-20-0047	Cable Hook Kit	(1)
98	45-94-0019	Wheel Mounting Kit	(2)

SEWER MACHINE EXTERNALS

EXAMPLE:
 Component Parts (Small #)
 Are Included When Ordering
 The Assembly (Large #).

- = Items shaded in grey are included in 42-92-0084 kit with hardware.
- = Items shaded in grey are included in 42-92-0082 kit with hardware.

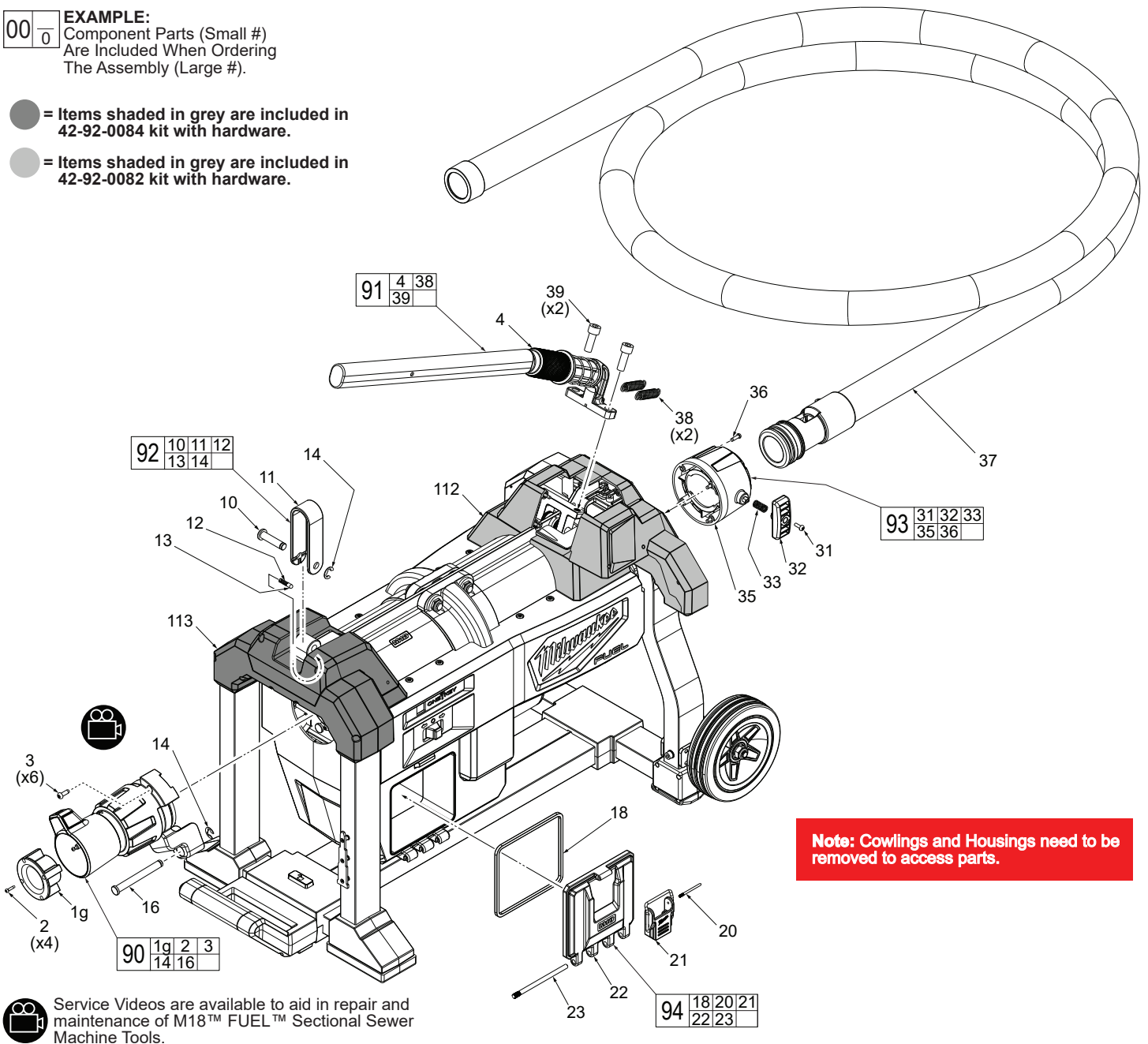

Note: Cowlings and Housings need to be removed to access parts.

Service Videos are available to aid in repair and maintenance of M18™ FUEL™ Sectional Sewer Machine Tools.

FIG.	PART NO.	DESCRIPTION OF PART	NO. REQ.	FIG.	PART NO.	DESCRIPTION OF PART	NO. REQ.
1g	-----	Clutch Shifting End Tube	(1)	31	05-81-1070	M4 x 12mm Pan Hd. T-20 Mach. Screw	(1)
2	06-82-0190	M3 x 14mm St. T-10 Screw	(4)	32	-----	Pilot Tube Release Handle	(1)
3	05-74-0190	M5 x 15mm PH T-25 Taptite Screw	(6)	33	-----	Pilot Tube Release Pin	(1)
4	-----	Lever Arm Assembly	(1)	35	-----	Pilot Tube Mounting	(1)
10	-----	Rod for Carry Loop	(1)	36	05-75-2407	M4 x 17mm CH T-20 Taptite Screw	(4)
11	-----	Carry Loop	(1)	37	47-53-2872	Guide Hose Assembly (Accessory)	(1)
12	-----	Carry Loop Spring	(1)	38	40-50-0226	Spring	(2)
13	-----	Carry Loop Detent	(1)	39	06-10-0665	M10 x 1.5 x 28mm Hex Hd. Bolt	(2)
14	42-70-0625	E-Clip	(2)	90	47-42-0058	Mode Selector Kit	(1)
16	-----	Shifting Rod	(1)	91	14-34-0031	Lever Arm Assembly	(1)
18	43-44-0033	Gasket for Battery Door	(1)	92	31-44-0227	Carry Loop Kit	(1)
20	-----	Pin	(1)	93	31-12-0036	Pilot Tube Mounting Kit	(1)
21	-----	Battery Door Latch	(1)	94	31-12-0032	Battery Door Kit	(1)
22	-----	Battery Door	(1)	112	42-92-0082	Top Rear Covers Kit	(1)
23	-----	Pin	(1)	113	42-92-0084	Top Front Covers Kit	(1)
28	12-20-0327	Service Nameplate (not Shown)	(1)				