



Model no.:	Stock no.:
Serial no.:	
Purchased from:	
Date purchased:	Date in service:

Operating Instructions and Parts Manual

JLP-A Series Manual Lever Hoists/Pullers

1/4- to 6-Ton

JLP-025A
1/4-ton



JLP-150A
1-1/2-ton



(models shown are representative of the series)

JET
427 New Sanford Road
LaVergne, Tennessee 37086
Ph.: 800-274-6848
www.jettools.com

Part No. M-187505
Revision D2 07/2018
Copyright © 2018 JET

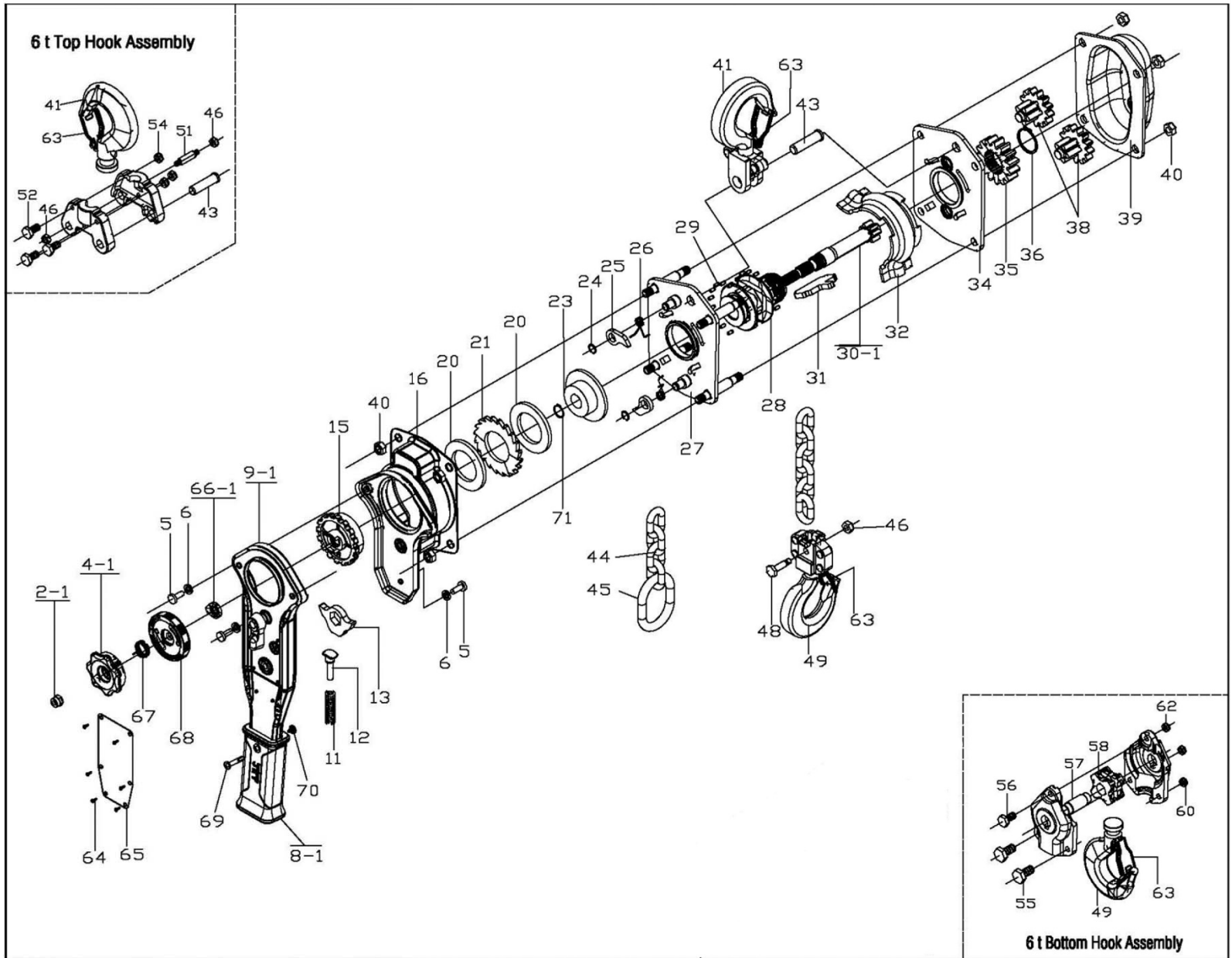

15.2.3 JLP-150A – Parts List

Index No.	Part No.	Description	Size	Qty
2-1	JLP150A-02-1	Lock Nut (1.5T, 3T, 6T)	M10	1
4-1	JLP150A-04-1	Hand Wheel Assembly (1.5T, 3T, 6T)		1
		Hand Wheel		1
		Steel Ball Spring		2
		Steel Ball		2
5	JLP150A-05G	Hex Head Screw (1.5T, 3T, 6T)	M8	3
6	JLP150A-06G	Spring Washer (1.5T, 3T, 6T)	Ø8 mm	3
8-1	JLP150A-08-1	Rubber Grip (1.5T, 3T, 6T)		1
9-1	JLP150A-09-1	Lever Handle Assembly (1.5T, 3T, 6T)		1
		Lever Handle		1
		Selector Lever		1
		Thread Housing		1
		Change Over Shaft		1
		Bushing		1
		Spring Seat		1
		Rivet		2
11	JLP150A-11	Change Over Spring (1.5T, 3T, 6T)		1
12	JLP150A-12	Spring Shaft (1.5T, 3T, 6T)		1
13	JLP150A-13	Change Over Pawl (1.5T, 3T, 6T)		1
15	JLP150A-15	Change Over Gear (1.5T, 3T, 6T)		1
16	JLP150A-16G	Brake Cover Assembly		1
		Brake Cover		1
		Handle Case		1
		Bushing		1
		Screw Nut		2
20	JLP150A-20	Friction Disc (1.5T, 3T, 6T)		2
21	JLP150A-21	Ratchet Disc (1.5T, 3T, 6T)		1
23	JLP150A-23	Brake Seat (1.5T, 3T, 6T)		1
24	JLP150A-24	Snap Ring	Ø9 mm	2
25	JLP150A-25	Pawl		2
26	JLP150A-26	Pawl Spring		2
27	JLP150A-27	Lever Side Plate Assembly		1
		Lever Side Plate		1
		Stay Bolt		4
		Pawl Pin		2
		Bearing Race		1
28	JLP150A-28	Load Sprocket		1
	JLP150A-28A	Load Sprocket (s/n 120606750 and higher)		1
29	JLP150A-29	Roller Set (Right and Left)	Ø3x6 mm	74
30-1	JLP150A-30-1	Driving Pinion		1
31	JLP150A-31	Stripper		1
32	JLP150A-32	Chain Guide Plate		1
34	JLP150A-34	Gear Side Plate Assembly		1
		Gear Side Plate		1
		Bearing Race		1
		Bushing		2
35	JLP150A-35	Load Gear		1
	JLP150A-35A	Load Gear (s/n 120606750 and higher)		1
36	JLP150A-36	Snap Ring	Ø30 mm	1
38	JLP150A-38	Spur Gear Assembly		2
39	JLP150A-39G	Gear Cover Assembly		1
		Gear Cover		1
		Bushing		2
		Gear Cover Plate		1
40	JLP150A-40G	Lock Nut (1.5T)	M10	8

Index No.	Part No.	Description	Size	Qty
41	JLP150A-41G	Top Hook Assembly (standard hook)		1
	JLP150A-41PHG	Top Hook Assembly (ship yard hook)		1
		Top Hook		1
		Top Hook Holder		2
		Safety Latch Kit		1
		Top Hook Shaft		1
43	JLP150A-43	Top Hook Shaft		1
44	JLP150A-44	Load Chain – <i>specify length</i>	Ø8x24 mm	1
45	JLP75A-45	Chain Stop (0.75T, 1.5T, 3T, 6T)		1
46	F001754	Load Pin Nut	M8	1
48	JLP150A-48	Load Pin		1
49	JLP150A-49G	Bottom Hook Assembly (standard hook)		1
	JLP150A-49PHG	Bottom Hook Assembly (ship yard hook)		1
		Bottom Hook		1
		Bottom Hook Holder		2
		Safety Latch Kit		1
		Rivet		4
		Load Pin		1
		Load Pin Nut	M8	1
63	JLP150A-63-1	Safety Latch Kit		2
		Safety Latch		2
		Double Spring		2
		Socket Cap Screw	M5x30	2
		Lock Nut	M5	2
64	JLP75A-64	Name Plate Rivet (0.75T, 1.5T, 3T, 6T)	Ø3x6 mm	4
65	LM000051	Name Plate JLP-150A		1
66-1	JLP150A-66-1	Stop Knob (1.5T, 3T, 6T)		1
67	JLP75A-67	Twisting Spring (0.75T, 1.5T, 3T, 6T)		1
68	JLP150A-68	Hand Wheel Base Assembly (1.5T, 3T, 6T)		1
		Hand Wheel Base		1
		Bushing		2
69	JLP75A-69	Rubber Grip Fastening (0.75T,1.5T,3T,6T)		1
70	JLP75A-70	Fastening Screw (0.75T,1.5T,3T,6T)		1
71	JLP150A-71	Snap Ring (1.5T, 3T, 6T)		1

Note: All parts mentioned as assembly are sold as an assembly only.

When ordering replacement chain (#44), specify length.