



Operating Instructions and Parts Manual Variable Speed Mill-Drill Machines

Models: JMD-45VSPF, JMD-45VSPFT



JMD-45VSPFT (tapping model) shown

JET
427 New Sanford Road
LaVergne, Tennessee 37086
Ph.: 800-274-6848
www.jettools.com

Part No. M-351050
Edition 2 11/2017
ECR 171106155622
Copyright © 2017 JET

12.1.1 JMD-45VSPF, -45VSPFT Table and Base Assembly – Exploded View

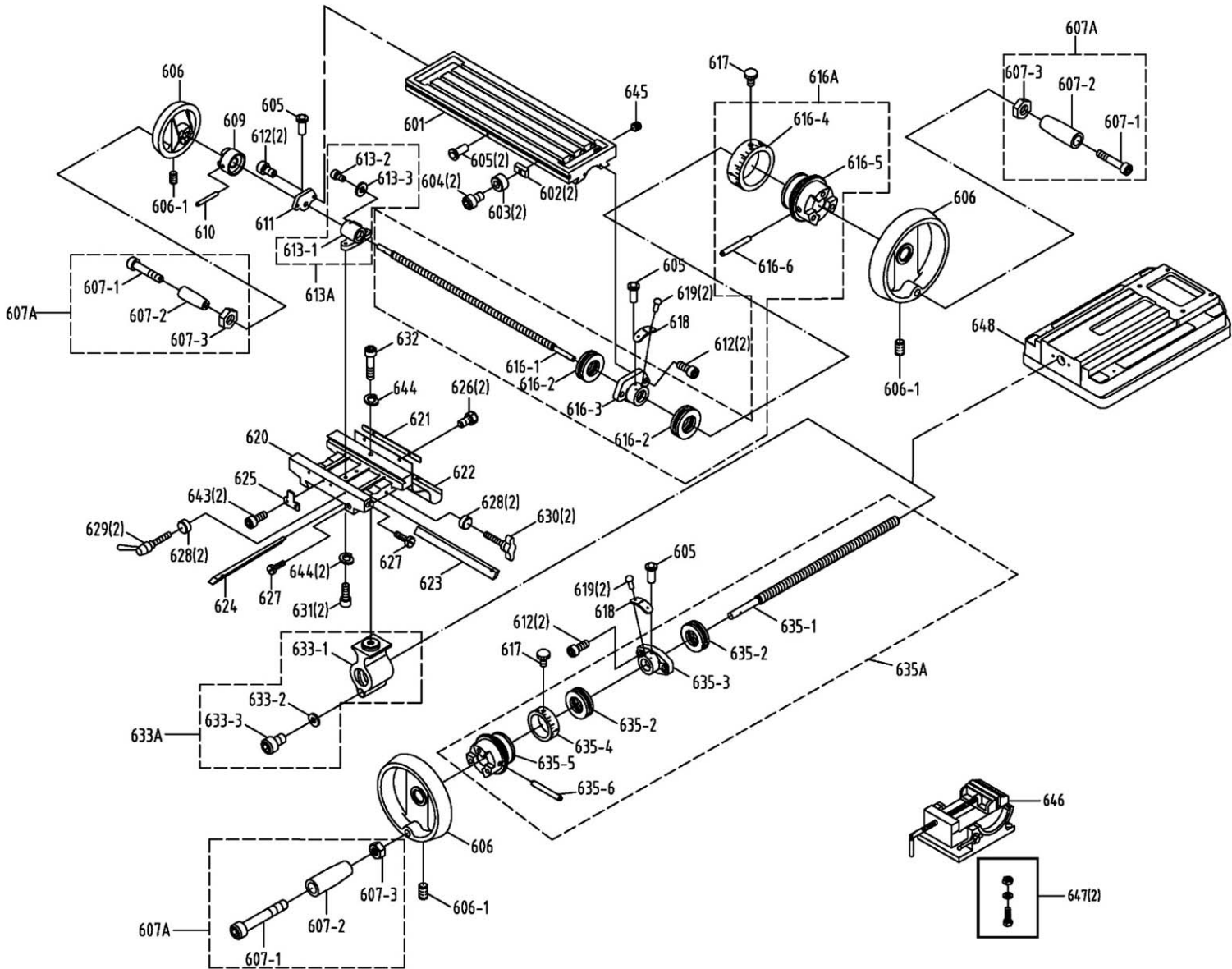

12.1.2 JMD-45VSPF, -45VSPFT Table and Base Assembly – Parts List

Index No.	Part No.	Description	Size	Qty
601	JMD18-228G	Table	31L	1
602	JMD18-229	Fixed T-Block		2
603	JMD18-230	Stop Ring		2
604	TS-0207021	Hex Socket Head Cap Screw	1/4"-20x1/2"	2
605	JMD18-368	Ball Oiler	1/4"	5
606	JMD18-201	Table Handwheel		3
606-1	TS-0267041	Set Screw	1/4"-20x3/8"	3
607A	JMD18-201A	Handle Assembly (#607-1 thru 607-3)		3
607-1	JMD18-201-1	Hex Socket Head Cap Screw (RE: JMD18-201-2)	3/8"-16x16	3
607-2	JMD18-201-2	Handle		3
607-3	TS-0561031	Hex Nut	3/8"-16	3
609	JMD18-220	Table Clutch		1
610	JMD18-366	Spring Pin	5x38L mm	1
611	JMD18-222	Left Flange		1
612	TS-0208061	Hex Socket Head Cap Screw	5/16"-18x1"	6
613A	JMD18-223A	Table Nut Set (#613-1 thru 616-3)		1
613-1	JMD18-223	Table Nut	TM23.7-10	1
613-2	TS-1502041	Hex Socket Head Cap Screw	M5-0.8x16	1
613-3	TS-1550031	Flat Washer	M5	1
616A	JMD18-224A	Table Screw Assembly (#616-1 thru 616-6)		1
616-1	JMD18-224	Table Lead Screw		1
616-2	BB-51103	Thrust Bearing	51103	2
616-3	JMD18-226	Right Flange		1
616-4	JMD18-202-1	Graduated Dial		1
616-5	JMD18-202	Dial Clutch		1
616-6	JMD18-366	Spring Pin	5x38L mm	1
617	JMD18N-617	Link Screw		2
618	JMD18-121	Indicator Plate		2
619	JMD18-204-2	Rivet	2mm	4
620	JMD18-216G	Center Base	31L	1
621	JMD18-219	Anti-Dust Plate		1
622	JMD18-217	Anti-Dust Plate Assembly		1
623	JMD18-227	Gib Strip	31L	1
624	JMD18-207	Gib Strip	31L	1
625	JMD18-214	Fixed Block		1
626	TS-0051011	Hex Cap Screw	5/16"-18x1/2"	4
627	JMD18-212	Gib Strip Bolt		2
628	JMD18N-628	Bushing		4
629	JMD18-213-1	Locking Handle		2
630	JMD18-213	Leaf Screw		2
631	TS-0208061	Hex Socket Head Cap Screw	5/16"-18x1"	2
632	TS-0051101	Hex Socket Head Cap Screw	5/16"-18x2-1/4"	1
633A	JMD18-215A	ACME Nut Assembly (#633-1 thru 633-3)		1
635A	JMD18-205A	ACME Nut Assembly (#635-1 thru 635-6)		1
635-1	JMD18-205	Cross Lead Screw	TM23	1
635-2	BB-51103	Thrust Bearing	51103	2
635-3	JMD18-204	Square Flange		1
635-4	JMD18-202-1	Graduated Dial		1
635-5	JMD18-202	Dial Clutch		1
635-6	JMD18-366	Spring Pin	5x38 mm	1
643	TS-0208022	Hex Socket Head Cap Screw	5/16"-24x1/2"	2
644	JMD18N-644	Lock Washer	5/16"	3
645	JMD18N-645	Plug	PT1/4"x3/8"	1
646	365534	Angle Vise		1
647	365534-01	Hardware Package (2 Bolts, 2 Nuts, 2 Washers)		1
648	JMD45GH-648	Base		1
	JMD40GH-AP	Accessory Package (not shown) *		1

* Contents of JMD40GH-AP Accessory Package:

.....JMD18-020.....	Cutter Arbor	1
.....JMD18-022.....	Handle	4
.....JMD18-039.....	Handle Rod.....	3
.....JMD18-040.....	Knob	3
.....JMD18-050.....	Lock Handle.....	1
.....561704	Drill Chuck w/Chuck Key	JT6, 1/2" (13mm) 1
.....JMD18-086.....	Face Mill Cutter Assembly.....	3" (74mm) 1
.....JMD18-086A	Cutter Insert (Installed)	4
.....JMD18-021.....	Chuck Arbor (Installed).....	1
.....365534	Angle Vise	1
.....JMD18-058.....	Handle Crank.....	1
.....JMD18-201.....	Wheel.....	3
.....TS-152704	Hex Wrench.....	3mm..... 1
.....TS-152705	Hex Wrench.....	4mm..... 1
.....TS-152706	Hex Wrench.....	5mm..... 1
.....TS-0209051	Hex Socket Cap Screw.....	3/8"-16x1" 1
.....TS-0680041	Flat Washer	3/8"..... 1
.....365534-01	Hardware Package (2 Bolts, 2 Nuts, 2 Washers)	1
.....JMD40GH-PW	Plum Wrench	1

12.2.1 JMD-45VSPF, -45VSPFT Column Assembly – Exploded View

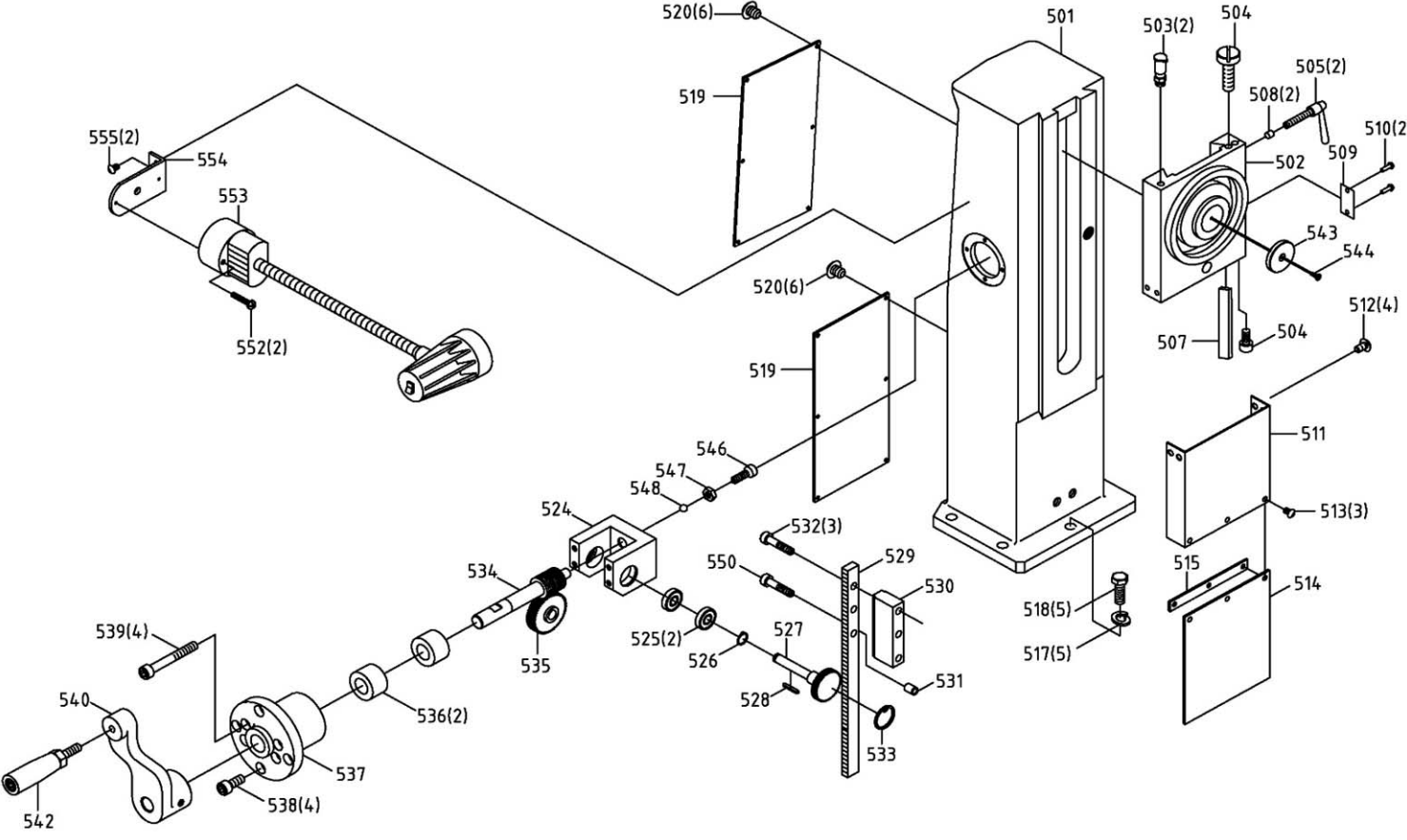

12.2.2 JMD-45VSPF, -45VSPFT Column Assembly – Parts List

Index No.	Part No.	Description	Size	Qty
501	JMD45GH-501	Vertical Square Column		1
502	JMD45GH-502	Headstock Swivel Base		1
503	JMD45GH-503	Oil Cup	PT1/8"	2
504	JMD45GH-504	Adjustable Screw		2
505	JMD45GH-505	Handle		2
507	JMD45GH-507	Gib		1
508	JMD45GH-508	Bushing		2
509	JMD45GH-509	Index		1
510	JMD45GH-510	Rivet	φ2-5L	2
511	JMD45GH-511	Anti-Dust Plate		1
512	F001216	Phillips Pan Hd Machine Screw BO	M5x10L	4
513	F001175	Phillips Pan Hd Machine Screw BO	M4x8L	3
514	JMD45GH-514	Anti-Dust Plate		1
515	JMD45GH-515	Press Board		1
517	TS-0720131	Lock Washer	5/8"	5
518	TS-0071051	Hex Cap Screw	5/8"-11x2-1/2"L	5
519	JMD45GH-519	Steel Plate		2
520	F001216	Phillips Pan Hd Machine Screw BO	M5x10L	12
524	JMD45GH-524	Bracket		1
525	BB-6003ZZ	Ball Bearing	6003ZZ	2
526	F006045	C-Retainer Ring, External	S17	1
527	JMD45GH-527	Gear Shaft		1
528	JMD45GH-528	Key, Double Rd. Head	5x5x28L mm	1
529	JMD45GH-529	Rack		1
530	JMD45GH-530	Block		1
531	JMD45GH-531	Bushing		1
532	F005671	Hex Socket Head Cap Screw	M12x85L	4
533	F006033	C-Retainer Ring, Internal	R35	1
534	JMD45GH-534	Worm Shaft		1
535	JMD45GH-535	Worm Gear		1
536	JMD45GH-536	Bearing		2
537	JMD45GH-537	Support Flange		1
538	TS-1504051	Hex Socket Head Cap Screw	M8x25L	4
539	TS-1504121	Hex Socket Head Cap Screw	M8x60L	4
540	JMD40GH-59-1	Crank		1
542	JMD18-201A	Handle Assembly		1
543	JMD45GH-543	Swivel Base Flange		1
544	JMD45GH-544	Hex Socket Flat Head Screw		1
546	TS-1504041	Hex Socket Head Cap Screw	M8x20L	1
547	TS-1540061	Hex Nut	M8	1
548	SB-6MM	Steel Ball	Ø6mm	1
550	F005461	Hex Socket Head Cap Screw	M12-1.75x75	1
552	TS-2284352	Pan Head Screw	M4x35L	2
553	JMD40GH-124	Lamp Assembly	110V	1
554	GHD20-126	Lamp Base		1
555	TS-1503031	Hex Socket Cap Screw	M6x12L	2

12.3.1 JMD-45VSPF, -45VSPFT Gear Head Assembly – Exploded View

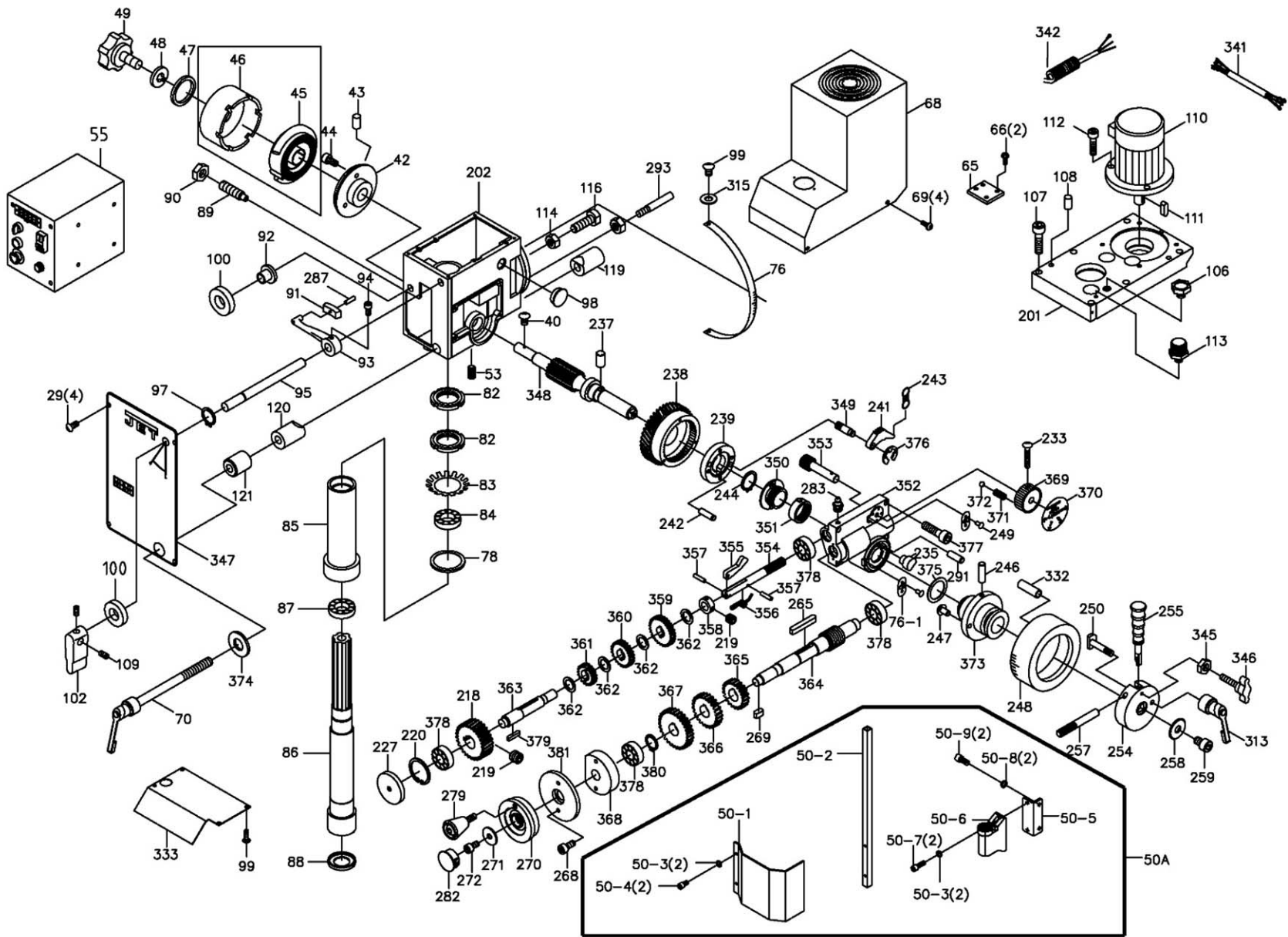

12.3.2 JMD-45VSPF, -45VSPFT Gear Head Assembly – Parts List

Index No.	Part No.	Description	Size	Qty
29	TS-081C022	Phillips Pan Hd Machine Screw	3/16"-24UNCx3/8"L	4
40	GHD20PF-40	Screw	3/16" x 3/8"	1
42	61105	Spring Base		1
43	GHD20PF-43	Spring Pin	3 x 12 mm	2
44	GHD20PF-44	Screw	3/16" x 3/4"	3
45	61103S	Spring and Cover (includes #46)		1
46	61103	Spring Cover (RE:61103S)		1
47	TS-0680021	Flat Washer	1/4"	1
48	TS-0720071	Lock Washer	1/4"	1
49	6185	Lock Knob		1
50A	GHD20-50-A	Chuck Guard Assembly (#50-1 thru 50-9)		1
50-1	JMD18-125-1	Chuck Guard and Support Rod		1
50-2	JMD18-125-2	Support Rod (RE:JMD18-125-1)		1
50-3	TS-2361051	Lock Washer	M5	4
50-4	TS-1502021	Hex Socket Head Cap Screw	M5 x 10	2
50-5	GHD20-50-5	Chuck Guard Bracket		1
50-6	JMD18-125-5	Rotary Support Base		1
50-7	JMD18-125-6	Hex Socket Head Cap Screw	M5 x 15L	2
50-8	TS-1551041	Lock Washer	M6	2
50-9	6286490	Hex Socket Head Cap Screw	M6 x 15L	2
52	TS-0071141	Hex Cap Screw	5/8"-11 x 5-1/2"	2
53	GHD20-53	Oil Plug	1/4"PT	1
55	JMD45VSPF-55	Electric Box Complete (JMD-45VSPF)		1
	JMD45VSPFT-55	Electric Box Complete (JMD-45VSPFT)		1
65	JMD45VSPF-65	Sensor Bracket		1
66	TS-1531012	Phillips Pan Hd Machine Screw	M3X5L	2
68	JMD45VSPF-68	Top Cover		1
69	F009884	Socket Head Button Screw	M5X8L	4
70	2421003	Handle Rod Assembly		1
76	2401076	Scale		1
76-1	2450060	Pointer		3
78	6112	Rubber Gasket		1
82	6114	Lock Nut		1
83	GHD20PF-83	Star Washer, External Tooth	M30	1
84	BB-30206	Taper Roller Bearing	30206	1
85	6116-R8	Quill	R8	1
86	6117-R8	Spindle Shaft	R8	1
87	BB-30207	Taper Roller Bearing	30207	1
88	6119	Bearing Cap		1
89	6127	Screw Key		1
90	TS-0561031	Hex Nut	3/8"-16	1
91	2401066	Gear Lever Bracket		1
92	JMD45VSPF-92	Plug		1
93	2401068	Gear Lever (Right)		1
94	TS-0207021	Hex Socket Head Cap Screw	1/4"-20 x 1/2"	1
95	2401070	Lever Shaft (Right)		1
96	2401071	Lever Shaft (Left)		1
97	GHD20PF-97	C-Ring, External	S12	1
98	GHD20PF-98	Oil Sight Glass		1
99	GHD20PF-99	Screw	3/16" x 3/8"	8
100	GHD20PF-100	Oil Seal	G12	2
102	2401075	Speed Lever		1
106	GHD20PF-106	Oil Plug		1
107	TS-0209081	Hex Socket Head Cap Screw	3/8"-16 x 3/4"	6
108	GHD20PF-108	Miter Pin		2
109	TS-0267021	Set Screw	1/4"-20 x 1/4"	2
110	JMD45VSPF-110	Motor	1.5HP 3PH 230V	1
111	GHD20PF-111	Double Rd. Hd. Key	6 x 6 x 30mm	1
112	TS-0209031	Hex Socket Head Cap Screw	3/8"-16 x 3/4"	6

Index No.	Part No.	Description	Size	Qty
113	GHD20-89	Brass Fitting		1
114	TS-0561071	Hex Nut	5/8"-11	3
116	F008242	Hex Cap Screw	5/8"-11 x 2-1/4"	3
119	6126-1	Collar (threaded)		1
120	6125-1	Collar Nut		1
121	6125-2	Collar		1
124	JMD40GH-124	Lamp Assembly	110V	1
125	TS-2284352	Phillips Pan Head Machine Screw	M4-0.7x35L	2
126	GHD20-126	Lamp Base		1
127	TS-1503031	Hex Socket Head Cap Screw	M6x12L	2
150	TS-0561071	Hex Nut	5/8"-11	2
151	TS-0680081	Flat Washer	5/8"	2
201	2450001G	Head Body Cover		1
202	2450002G	Head Body Casting		1
218	2450008	Worm Gear		1
219	TS-1523011	Set Screw	M6 x 6	4
220	F006033	C-Ring, Internal	R35	4
227	2450014	Cover		1
233	GHD20PF-233	Screw	M4 x 25	1
235	2450020	Release Block		1
236	2450021	Small Pinion Shaft		1
237	2450022A	Cylindrical Key	M8x12	2
238	2450023	Worm Gear		1
239	2450024	Clutch Key Base		1
241	2450026	Clutch Key		2
242	2450027	Spring Pin	Ø5x18L	2
243	2450028	Spring		2
244	GHD20PF-244	C-Ring, External	S25	1
246	2450030	Bushing Pin		1
247	2450031	Bushing Stop		1
248	2450032	Scale Base		1
249	GHD20PF-249	Rivet	Ø2x4L	8
250	2450033	Scale Base Set Screw		1
254	2450037	Handle Hub		1
255	2450038N	Handle Rod		2
257	2450039	Handle Rod Pin		2
258	2450040	Washer		1
259	TS-1504021	Hex Socket Head Cap Screw	M8-1.25 x 12	1
265	GHD20PF-265	Double Rd. Hd. Key	5 x 5 x 32mm	1
266	2450045	Cover		1
268	TS-1502031	Hex Socket Head Cap Screw	M5-0.8 x 12	2
269	GHD20PF-269	Key	4 x 4 x 10mm	1
270	24500470	Handwheel		1
271	GHD20PF-271	Washer		1
272	TS-1503031	Hex Socket Head Cap Screw	M6-1.0 x 12	1
279	JMD40GH-279	Handle Assembly	5/16"	1
282	GHD20PF-282	Plug	7/8"	1
283	GHD20PF-283	Oil Seal		1
287	GHD20PF-287	Spring Pin	4x16mm	1
291	2450051	Pin		1
293	HP309	Taper Pin	M6xØ7 (1:48)	1
313	2450063	Handle		1
315	TS-0680011	Flat Washer	3/16"	2
332	GHD20PF-332	Pin	Ø5x15L	1
333	2450069	Dust Plate		1
341	JMD45VSPF-341	Motor Cord	14AWGX4C	1
342	JMD45VSPF-342	Power Cord		1
345	TS-0640081	Hex Nut	5/16"-18	1
346	GHD20PF-346	Manual Feed Knob		1
347	JMD45VSPF-347	Name Plate for JMD-45VSPF		1
	JET-92	JET Logo (not shown)	92x38MM	1
348	2450086A	Pinion Shaft		1

Index No.	Part No.	Description	Size	Qty
349	2450097	Clutch Key Pin	Ø7x23L mm	2
350	2450096	Clutch Screw		1
351	2450095	Clutch Nut		1
352	2450068G	Gear Box		1
353	2450081A	Gear Shaft		1
354	2450082A	Speed Change Lever		1
355	2450083A	Stop		1
356	2450084A	Spring Leaf		1
357	GHD20PF-357	Pin	Ø3x10L mm	2
358	2450089A	Fixed Bushing		1
359	2450072A	Gear		1
360	2450071A	Gear		1
361	2450070A	Gear		1
362	2450074A	Washer		4
363	2450073A	Shaft		1
364	2450078A	Transmission Worm		1
365	2450075A	Gear		1
366	2450076A	Gear		1
367	2450077A	Gear		1
368	2450085A	Spacer Ring		1
369	2450079	Speed Lever		1
370	GHD20PF-370	Speed Scale		1
371	290089	Spring		1
372	SB-8MM	Steel Ball	8mm	1
373	2450087A	Clutch Bushing		1
374	GHD20-374	Flat Washer	1/2" x 7/8" x 2"	1
375	2450100	Washer		1
376	GHD20PF-376	E-Retainer Ring	E5	2
377	TS-0208071	Hex Socket Head Cap Screw	5/16"-18 x 1-1/4"L	4
378	CA6003ZZ	Ball Bearing		4
379	GHD20PF-379	Double Rd. Hd. Key	5 x 5 x 28L mm	1
380	GHD20PF-380	C-Ring		1
381	2450088A	Graduated Bottom Plate		1
	LM000292	ID/Warning Label, JMD-45VSPF (not shown)		1
	LM000293	ID/Warning Label, JMD-45VSPFT (not shown)		1

12.5.1 JMD-45VSPF, -45VSPFT Gears Assembly – Exploded View

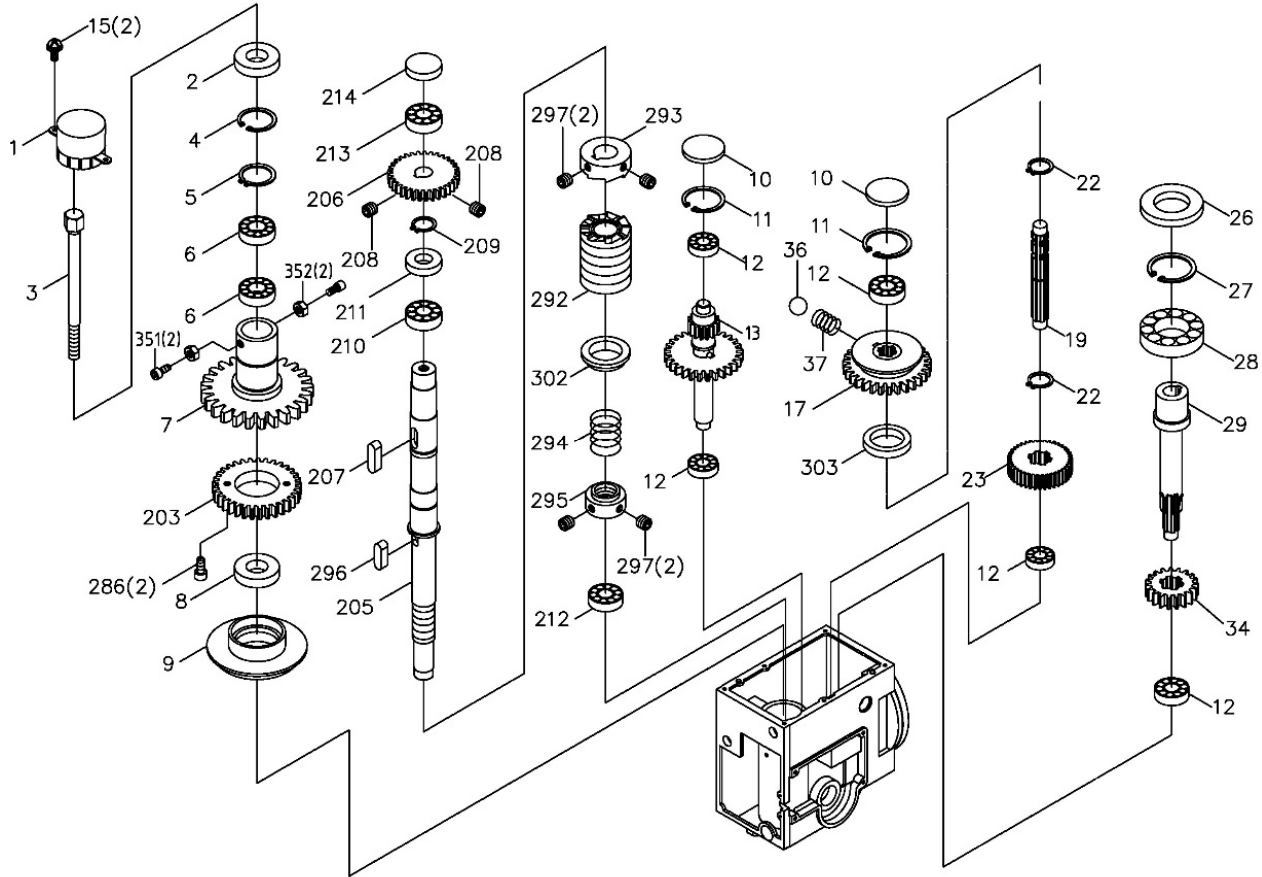

12.5.2 JMD-45VSPF, -45VSPFT Gears Assembly – Exploded View

Index No.	Part No.	Description	Size	Qty
1	JMD45VSPF-100	Main Shaft Cover		1
2	GHD20-28	Oil Seal		1
3	JMD45GH-03	Draw Bar	7/16"	1
4	GHD20-4	Retainer Ring, Internal	R68	1
5	GHD20PF-5	Retainer Ring, External	S40	1
6	BB-6008ZZ	Ball Bearing	6008ZZ	2
7	2401006	Idle Gear	53T	1
8	GHD20-7	Oil Seal		1
9	2401008	Oil Seal Ring		1
10	GHD20-9	Dust Cover		2
11	GHD20-10	C-Ring		2
12	BB-6002ZZ	Ball Bearing	6002ZZ	5
13	2401020A	Gear Shaft Assembly	15/41T	1
15	TS-1532032	Phillips Pan Hd Machine Screw	M4-0.7x10L	2
17	2401029N	Idle Gear	42T/16T	1
19	2401031	Pinion Shaft		1
22	GHD20-33	C-Ring, Ext	S18	2
23	241004A	Idle Gear	31T	1
26	GHD20-50	Oil Seal		1
27	GHD20-42	C-Ring, Internal	R62	1
28	BB-6007ZZ	Ball Bearing	6007ZZ	1
29	2401043	Pinion Shaft		1
34	241003B	Idle Gear	28T	1
36/37	GHD20-30	Steel Ball w/ Spring	5/16"	1
203	2450003	Idle Gear	33T	1
205	2450004	Transmission Worm		1
206	2450005	Idle Gear	33T	1
207	GHD20PF-207	Double Rd. Hd. Key	5x5x16	1
208	TS-1523011	Set Screw	M6x6	2
209	GHD20PF-209	C-Ring, External	S17	2
210	BB-6003ZZ	Ball Bearing	6003ZZ	1
211	GHD20PF-211	Oil Seal		1
212	BB-6001ZZ	Ball Bearing	6001ZZ	1
213	BB-6202ZZ	Ball Bearing	6202ZZ	1
214	GHD20-214	Oil Seal Cover		1
286	TS-1502031	Hex Socket Head Cap Screw	M5x12	2
292	2450052	Worm Shaft		1
293	2450053	Clutch Block		1
294	2450054	Spring		1
295	2450055	Adjustable Bolt		1
296	GHD20PF-296	Key	5x5x10	1
297	GHD20PF-297	Set Screw	M5x5	4
302	2450057	Washer		1
303	2401192	Bushing		1
351	TS-1503011	Hex Socket Head Cap Screw	M6x8L	2
352	TS-1540041	Hex Nut	M6	2

12.6.1 JMD-45VSPF Electric Box Assembly – Exploded View

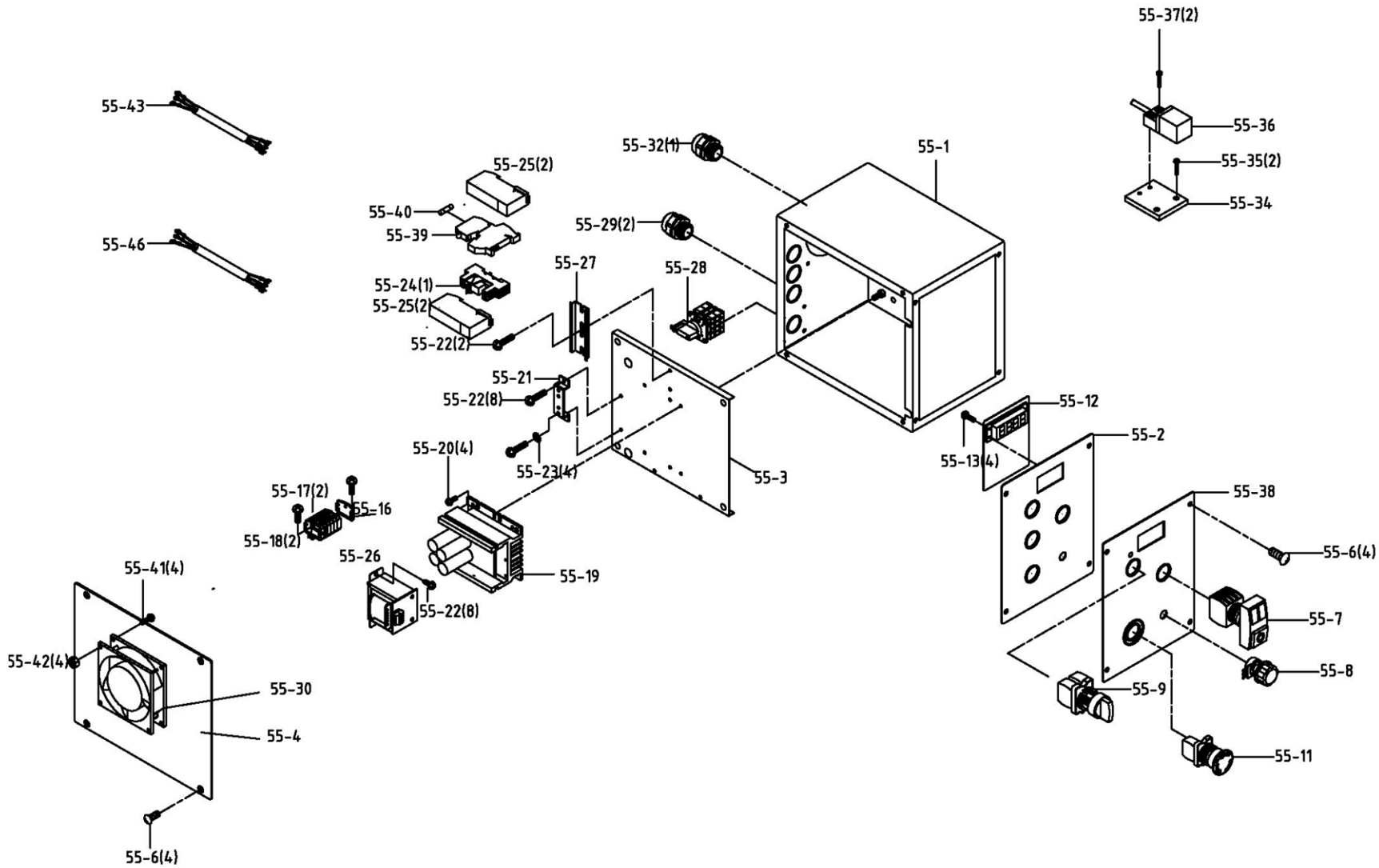

12.6.2 JMD-45VSPF Electric Box Assembly – Parts List

Index No.	Part No.	Description	Size	Qty
	JMD45VSPF-55	Electric Box Complete (JMD-45VSPF)		1
55-1	JMD45VSPF-55-1	Electric Box		1
55-2	JMD45VSPF-55-2	Front Cover		1
55-3	JMD45VSPF-55-3	Back Plate		1
55-4	JMD45VSPF-55-4	Side Cover		1
55-5	JMD45VSPF-55-5	DRO PC Board (not shown)		1
55-6	TS-2245102	Socket Hd Button Screw	M5X10L	8
55-7	JMD45VSPF-55-7	Double Switch w/ Light		1
55-8	JMD45VSPF-55-8	VR Switch		1
55-9	JMD45VSPF-55-9	Turn Switch	NSS-22S3	1
55-11	JMD45VSPF-55-11	Emergency Switch		1
55-12	JMD45VSPF-55-12	Digital Read Out		1
55-13	TS-2283102	Phillips Pan Head Machine Screw	M3x10L	4
55-16	JMD45VSPF-55-16	Side Plate		1
55-17	JMD45VSPF-55-17	Terminal		2
55-18	TS-2171012	Phillips Pan Head Machine Screw	M4x6	2
55-19	JMD45VSPF-55-19	Inverter	RFVF-26D	1
55-20	TS-1532032	Phillips Pan Head Machine Screw	M4x10L	4
55-21	JMD45VSPF-55-21	Copper Grounding Plate		1
55-22	TS-2284082	Phillips Pan Head Machine Screw	M4x8L	8
55-23	TS-0733031	Lock Washer, Ext Tooth	#10 (M5)	4
55-24	JMD45VSPF-55-24	Relay	24V	1
55-25	JMD45VSPF-55-25	Fixed Plate		2
55-26	JMD45VSPF-55-26	Transformer		1
55-27	JMD45VSPF-55-27	Switch bracket		1
55-28	JMD45VSPF-55-28	Main Power w/ Lock Key	48x48	1
55-29	SR-PG11	Strain Relief	PG11	2
55-30	JMD45VSPF-55-30	Fan	110V	1
55-32	SR-PG8	Strain Relief	PG8	1
55-34	JMD45VSPF-55-34	Bracket		1
55-35	TS-2283102	Phillips Pan Head Machine Screw	M3x10L	2
55-36	JMD45VSPF-55-36	Sensor		1
55-37	JSH275-43-1	Phillips Pan Head Machine Screw	M3x16L	2
55-38	JMD45VSPF-55-38	Control Panel for JMD-45VSPF		1
55-39	JMD45VSPF-55-39	Fuse Bracket		1
55-40	JMD45VSPF-55-40	Fuse	0.5A 2CM	1
55-41	2SS-3C-01701	Phillips Pan Head Machine Screw	M4x40L	4
55-42	TS-1540021	Hex Nut	M4	4
55-43	JMD45VSPF-55-43	Motor Cord		1
55-46	JMD45VSPF-55-46	Power Cord	SJT 14x3C	1