



# SERVICE PARTS LIST

**BULLETIN NO.**  
**55-16-7050**

SPECIFY CATALOG NO. AND SERIAL NO. WHEN ORDERING PARTS		REVISED BULLETIN	DATE
<b>DYMODRILL with INTERNAL CLUTCH</b>			Feb. '97
CATALOG NO. <b>4096-55</b>	STARTING SERIAL NO. <b>798A</b>	WIRING INSTRUCTION <b>58-03-0021</b>	

**EXAMPLE:**



Component Parts (Small #)  
Are Included When Ordering  
The Assembly (Large #).

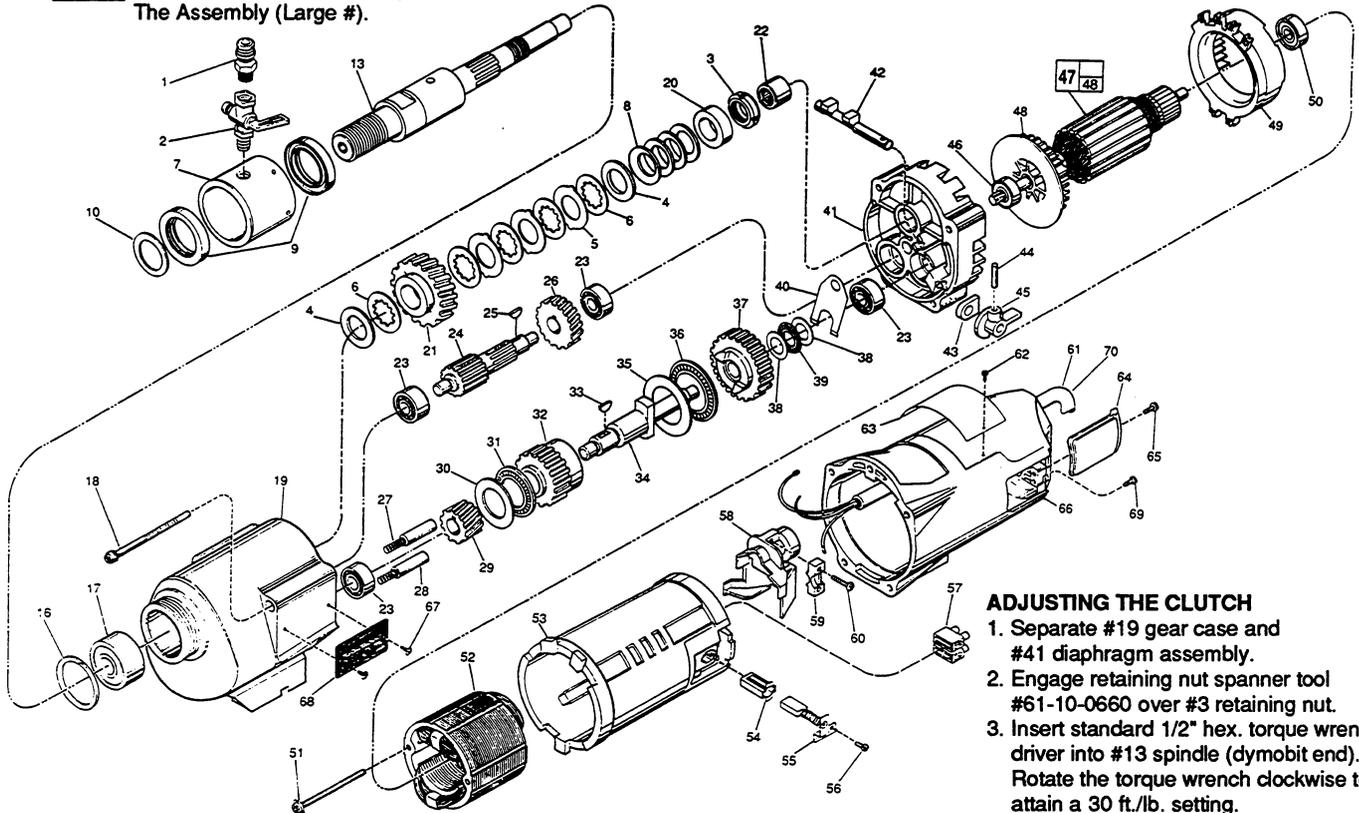

**ADJUSTING THE CLUTCH**

1. Separate #19 gear case and #41 diaphragm assembly.
2. Engage retaining nut spanner tool #61-10-0660 over #3 retaining nut.
3. Insert standard 1/2" hex. torque wrench driver into #13 spindle (dymobit end). Rotate the torque wrench clockwise to attain a 30 ft./lb. setting.

FIG.	PART NO.	DESCRIPTION OF PART	NO. REQ.	FIG.	PART NO.	DESCRIPTION OF PART	NO. REQ.
1	42-90-0210	Water Hose Fitting	(1)	45	25-60-0056	Shifting Knob	(1)
2	45-80-0060	Shut Off Valve	(1)	46	02-04-1229	Ball Bearing	(1)
3	06-57-1050	Retaining Nut	(1)	47	16-70-0320	Armature	(1)
4	45-88-1140	Thrust Washer	(2)	48	22-84-0790	Fan	(1)
5	43-06-0160	Clutch Disc-Outer	(3)	49	42-14-0291	Baffle	(1)
6	43-06-0150	Clutch Disc-Inner	(5)	50	02-04-1041	Ball Bearing	(1)
7	43-76-0051	Water Swivel Hsg. (With 06-83-2430 Scr.)	(1)	51	06-82-9152	10-24 x 2-3/4" Pan Hd. Sem. T-25	(2)
8	40-50-2150	Disc Spring	(4)	52	18-70-0290	Field	(1)
9	45-06-0635	Seal	(2)	53	23-16-1410	Motor Insulator	(1)
10	45-88-8565	Washer (Bag of 2)	(1)	54	22-20-0680	Brush Tube	(2)
13	38-50-6020	Spindle	(1)	55	22-18-0702	Carbon Brush Assembly	(2)
16	34-80-3800	Retaining Ring	(1)	56	06-82-8835	8-32 x 5/16" Pan Hd. Sem.T-20	(2)
17	02-20-2515	Ball Bearing	(1)	57	22-56-0470	Terminal Block	(1)
18	06-82-9202	1/4-20 x 4-1/4" Taptite T-30	(4)	58	22-38-0140	Wire Trap	(1)
19	28-14-1870	Gear Case Assy.(Inc. 06-65-1535 Pin)	(1)	59	31-17-0200	Cord Clamp	(1)
20	45-36-1520	Spindle Spacer	(1)	60	06-82-7326	8-16 x 1" Pan Hd. Plastite T-20	(2)
21	32-75-3420	Spindle Gear	(1)	61	23-37-0155	Control Assy. (See Bull. 58-03-0021)	(1)
22	02-50-4830	Needle Bearing	(1)	62	06-72-1720	Service Rivet	(2)
23	02-04-1205	Ball Bearing	(4)	63	12-99-2155	Service Nameplate	(1)
24	36-66-3751	Pinion Shaft Assy.	(1)	64	22-32-0350	Brush Cover	(2)
25	06-42-1600	Woodruff Key	(1)	65	06-82-5316	8-32 x 1/2" Pan Hd. Slit. Taptite T-20	(2)
26	32-40-1581	Intermediate Gear	(1)	66	28-50-6363	Motor Housing	(1)
27	40-50-6300	Shifting Spring	(2)	67	06-82-5266	4-40 x 1/4" Pan Hd. Taptite T-10	(2)
28	44-70-0100	Shifting Plunger	(2)	68	12-98-3060	Instruction Plate	(1)
29	32-60-1041	Pinion Gear	(1)	69	05-81-0470	M5 x 8mm Sems	(1)
30	45-88-0520	Thrust Bearing Washer	(1)	70	22-36-0160	PRCD (See Bulletin No. 58-03-0021)	(1)
31	02-80-1800	Thrust Bearing	(1)		49-96-4700	1-3/8" Open End Wrench	(1)
32	32-10-0061	Clutch Gear Assembly	(1)		49-96-0050	3/32" Hex Socket Wrench	(1)
33	06-42-2000	Woodruff Key	(1)		49-96-0085	3/16" Hex Socket Wrench	(1)
34	36-14-0061	Clutch Shaft	(1)		45-56-0210	Strap And Buckle	(1)
35	45-88-0530	Thrust Bearing Washer	(1)		61-10-0660	Retaining Nut Spanner Tool	(1)
36	02-80-5000	Thrust Bearing	(1)				
37	32-10-0051	Clutch Gear Assembly	(1)				
38	45-88-0510	Thrust Bearing Washer	(2)				
39	02-80-1200	Thrust Bearing	(1)				
40	45-98-0090	Shifting Yoke	(1)				
41	14-13-0210	Diaphragm Assy.(Inc. 06-65-1155 Pin)	(1)				
42	30-15-0272	Shift Cam	(1)				
43	43-44-0580	Foam Gasket	(2)				
44	06-65-0840	1/8 x 3/4" Groove Pin	(1)				

**FOR MOUNTING DRILL MOTOR USE:**  
06-75-3090 1/4-20 x 7/8" Socket Hd. Screw (4)  
06-97-4050 1/4" Split Ring Lock Washer (4)

**FIG. LUBRICATION**  
19 18 Oz. Type "J" Grease, No. 49-08-4220.

**MILWAUKEE ELECTRIC TOOL CORPORATION**  
13135 W. LISBON RD., BROOKFIELD, WI 53005