



# SERVICE PARTS LIST

BUL. 54-14-2001

3/4" ELECTRIC DRILL

REVISED BUL  
6299-2

DATE  
FEB. '68

Catalog No. 4260-1

Starting  
Serial No. 299-1199

WIRING INSTR.

Both Model and Serial No. must be furnished to obtain correct parts.

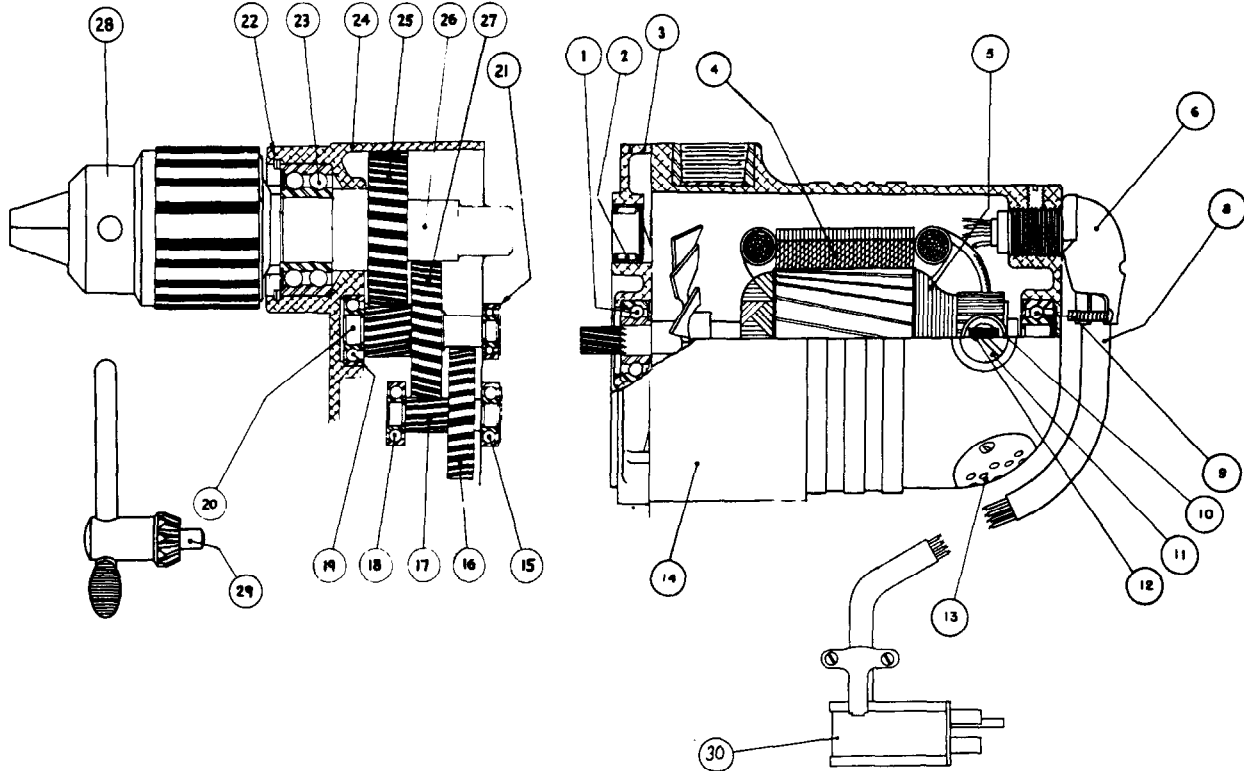

230V Motor  
16-86-1071 Armature  
18-86-1050 Field

### ILLUSTRATED PARTS

FIG.	PART NO.	DESCRIPTION OF PART
1	02-04-1140	Ball Bearing (Pinion End)
2	02-50-4820	Needle Bearing
3	28-28-0301	Diaphragm
4	18-82-1060	Field Assembly
5	16-82-1091	Armature Assembly
6	22-56-0060	Right Angle Connector
8	22-60-2200	Cord (Wire-4)
9	02-04-1070	Ball Bearing
10	22-22-0015	Brush Holder Assembly
11	23-44-0030	Brush Retaining Screw
12	22-18-0055	Carbon Brush Assembly
13	44-66-0180	Air Intake Cover Plate
14	28-50-4121	Motor Housing
15	02-04-0910	Ball Bearing

FIG.	PART NO.	DESCRIPTION OF PART
16	32-42-1201	Intermediate Gear
17	36-66-1251	Pinion Shaft
18	02-04-0910	Ball Bearing
19	02-04-1210	Ball Bearing
20	36-66-1301	Pinion Shaft
21	02-04-0820	Ball Bearing
22	34-80-3800	Retaining Ring
23	02-20-2520	Ball Bearing
(2)	24	28-14-0091 Gear Case
(2)	25	32-75-1261 Spindle Gear
(2)	26	38-50-4251 Spindle
27	32-44-1141	Intermediate Gear
28	48-66-2080	Chuck
29	48-66-3160	Chuck Key
30	22-56-0210	Cinch Plug

### MISCELLANEOUS PARTS NOT SHOWN

PART NO.	DESCRIPTION OF PART	PART NO.	DESCRIPTION OF PART
12-98-0900	Name Plate	06-38-0060	1/4-20x3/8 Helicoil (4)
06-85-0200	6x1/4 P.K. Air Intake Plate Screws (2)	06-81-2100	1/4-20x3-1/4 Fil. Hd. Gear Case Scrs. (2)
45-30-0070	Ball Bearing Retainer Slug	06-42-1200	No. 212 Woodruff Key
06-77-0450	No. 4x1/4 Driv-In Name Plate Screws (2)	06-42-2000	No. 3 Woodruff Key
06-81-1975	1/4-20x2-1/4 Fil. Hd. Gear Case Screws (2)	06-42-2400	No. 61 Woodruff Key
06-83-2650	1/4-20x3/8 Hd'less Brush Holder Set Scrs. (2)	44-66-0050	Body Cover Plate
06-83-2645	1/4-20x3/8 Hd'less Set Screws (3)	06-81-4700	1/4-20x1/2 Rd. Hd. Screws (4)
06-38-0059	1/4-20x1/4 Helicoil (4)	06-81-9225	10-24x2-3/4 Lg. Rd. Hd. Field Screws (2)
		45-36-0080	Spindle Spacer