



# SERVICE PARTS LIST

BULLETIN NO.  
55-04-0125

SPECIFY CATALOG NO. AND SERIAL NO. WHEN ORDERING PARTS		REVISED BULLETIN	DATE
<b>CHARGER</b>			Sept. '93
CATALOG NO. 48-59-0035	STARTING SERIAL NO. EGJC	WIRING INSTRUCTION <b>SEE REVERSE SIDE</b>	

**EXAMPLE:**

00 0 Component Parts (Small #) Are Included  
When Ordering The Assembly (Large #).

FIG.	PART NO.	DESCRIPTION OF PART	NO. REQ.
1	22-64-3300	Cord Set (See Note)	(1)
2	31-50-0821	Top Housing	(1)
3	31-50-0831	Bottom Housing	(1)
4	06-82-7236	4-20 x 5/8" Pan Hd. Plast. Torx	(5)
5	-----	Transformer	(1)
6	-----	Circuit Board	(1)
7	44-76-0220	Strain Relief	(1)
8	23-74-0890	Terminal	(2)
9	44-52-0490	Foam Pad	(1)

**NOTE**

Cord Set requires terminals  
No. 23-74-0890 --- sold separately.  
Transformer requires foam  
pad No. 44-52-0490 ---  
sold separately.

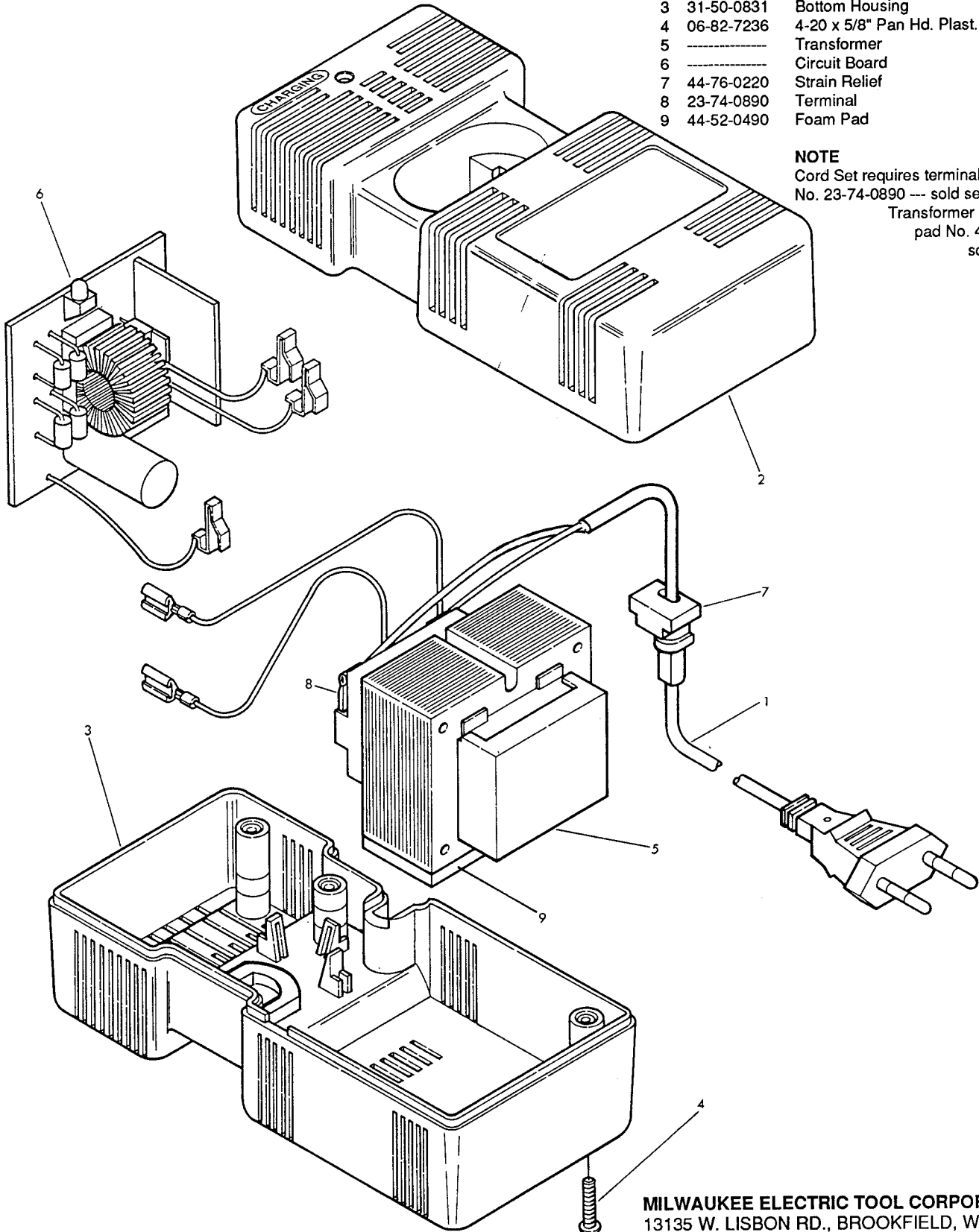

**MILWAUKEE ELECTRIC TOOL CORPORATION**  
13135 W. LISBON RD., BROOKFIELD, WI 53005 USA

**NOTE:**

INSULATED TERMINAL T2 MAY BE USED ON BOTH THE INSIDE AND OUTSIDE TABS BUT MUST BE USED ON THE INSIDE POSITION AS SHOWN.

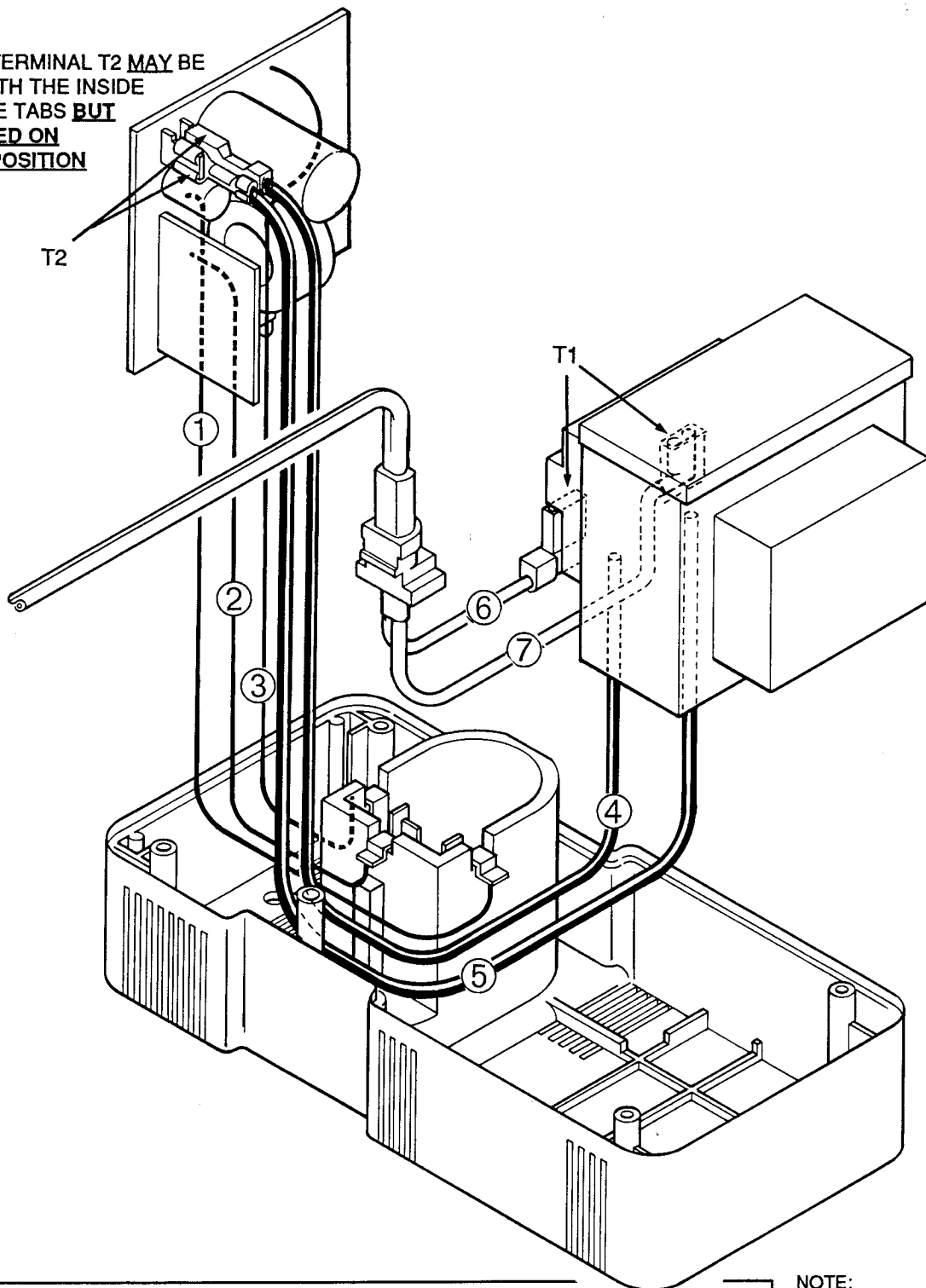

**WIRING SPECIFICATIONS**

Wire No.	Wire Color	Origin or Gauge	Length	Terminals, Connectors and 1 or 2 End Wire Preparation
1	Red	22 Ga.	4-1/2"	Component of circuit board assembly.
2	Red	22 Ga.	3-3/4"	Component of circuit board assembly.
3	Red	22 Ga.	2-1/4"	Component of circuit board assembly.
4	Yellow	20 Ga.	6"	Strip 1/4" for T2.
5	Yellow	20 Ga.	6"	Strip 1/4" for T2.
6	Black	18 Ga.	1-1/2"	Strip 3/16" for T1.
7	Black	18 Ga.	3"	Strip 3/16" for T1.

**NOTE:**

All leads must be held to  $\pm 1/8"$ .  
All field leads to be measured from and perpendicular to laminations.  
All lead lengths are before stripping.

**TERMINAL DESCRIPTION**

Code	Part No.	Qty.
T1	23-74-0890	2
T2	23-74-0440	2

**CONNECTOR DESCRIPTION**

Code	Part No.	Qty.