



SERVICE PARTS LIST

BULLETIN NO.
54-04-0220

SPECIFY CATALOG NO. AND SERIAL NO. WHEN ORDERING PARTS		REVISED BULLETIN	DATE
POWER PLUS FAST CHARGER			Apr. '97
CATALOG NO. 48-59-0225	SERIAL NUMBER 914A	WIRING INSTRUCTION	

00/0

EXAMPLE:
Component Parts (Small #) Are Included
When Ordering The Assembly (Large #).

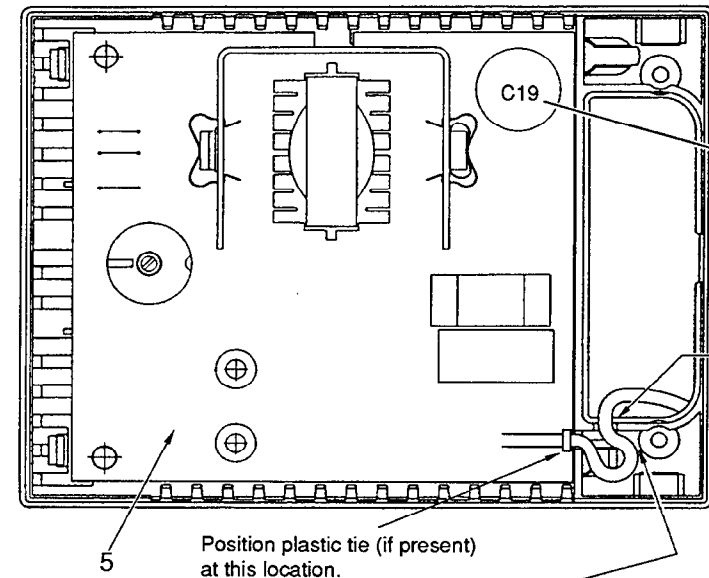
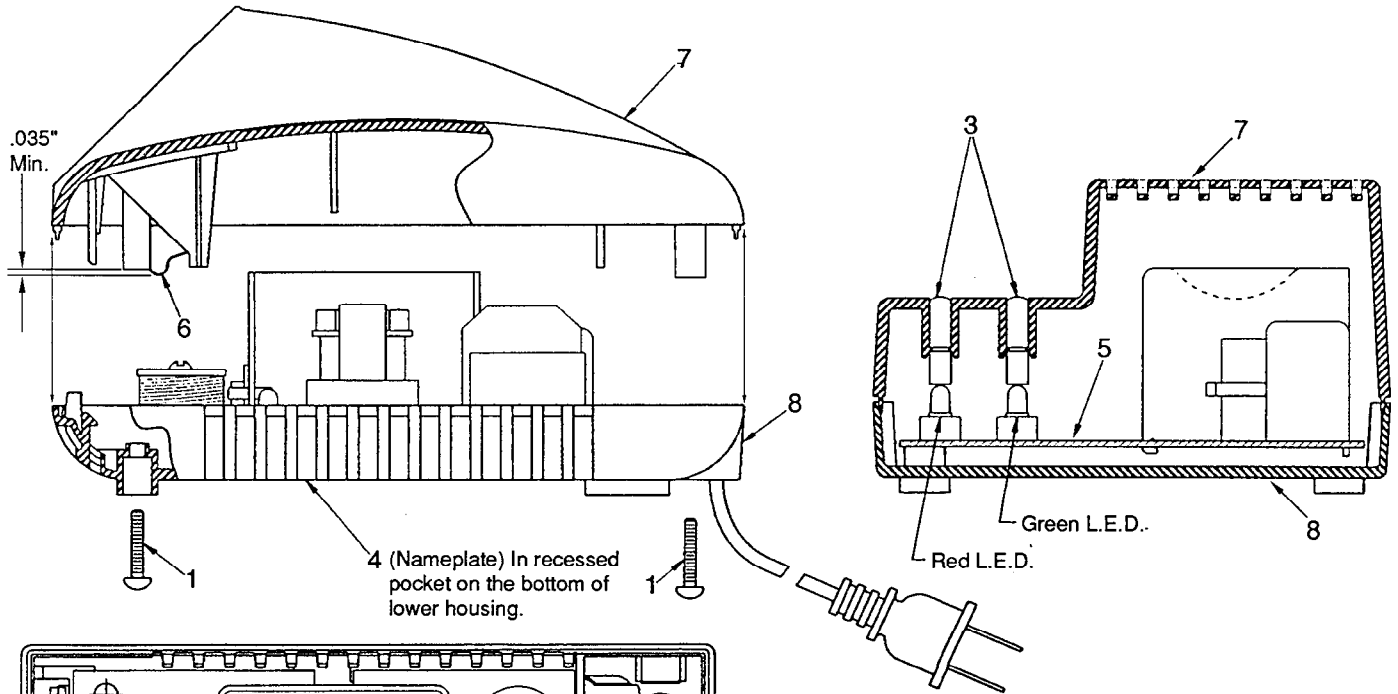

WARNING
Handle circuit board with care. High voltage, 191 VDC, may be present at C19 and could result in a shock.

Cordset to be positioned through lower housing slot to allow for .50"-.25" of slack.

Cordset to be positioned around the strain relief post in the lower housing to allow for a .06" gap between the cordset and the screw boss pad.

FIG.	PART NO.	DESCRIPTION OF PART	NO. REQ.
1	06-82-9207	6-32 x 11/16" Pan Hd. Slit. PT T-10	(4)
2	22-64-1041	Cordset	(1)
3	-----	Light Pipe	(2)
4	12-20-0825	Service Nameplate Kit	(1)
5	-----	Circuit Board Assembly	(1)
6	-----	Battery Contact	(3)
7	31-50-1352	Upper Housing	(1)
8	31-50-1355	Lower Housing	(1)

- FIG. NOTES**
- 5 Circuit board assembly to be fully seated on the lower housing screw bosses so that the top of the boss is flush with the top of the circuit board assembly.
 - 2 Cordset terminals to be fully seated on their mating terminals and separated from one another by a minimum of .125".
 - 7, 8 Verify that the top housing is fully seated on the lower housing prior to installing the screws.

MILWAUKEE ELECTRIC TOOL CORPORATION
13135 W. LISBON RD., BROOKFIELD, WI 53005