



SERVICE PARTS LIST

BUL. 54-22-0122

1/3 H.P. BENCH GRINDER

REVISED BUL DATE
Dec. '76

Catalog No. **4920**

MODEL REF. NO. **40000-U**

WIRING INSTR.

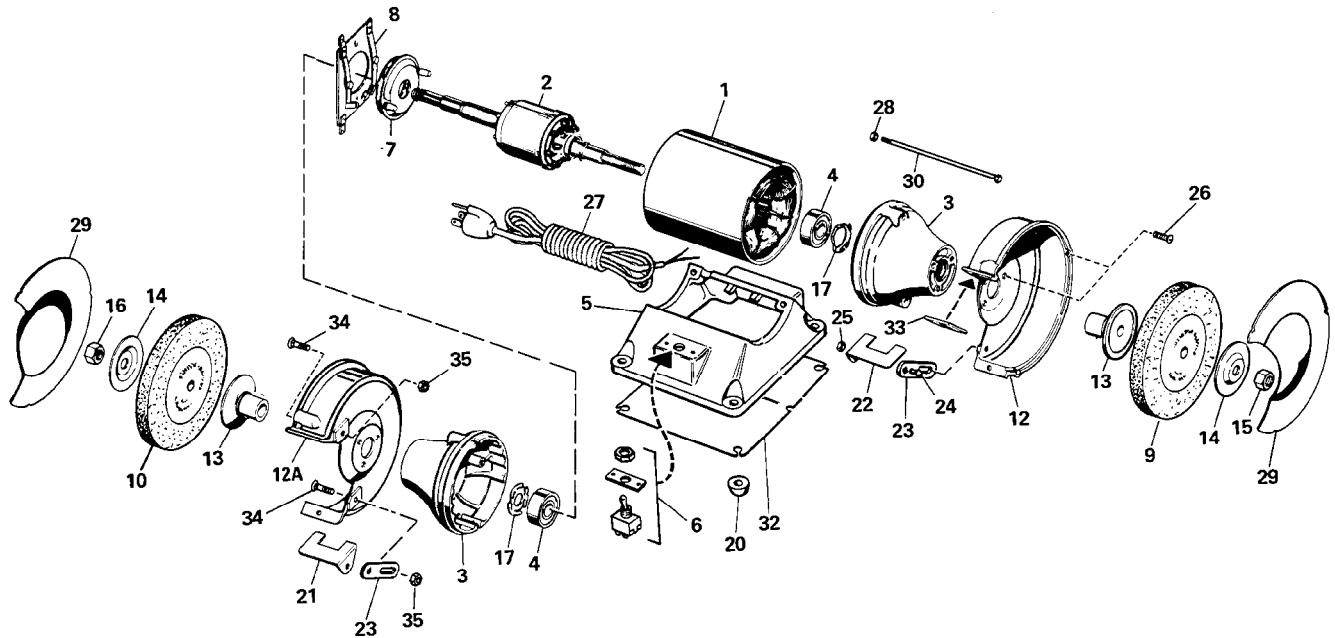

PARTS ORDERS MUST INCLUDE:
 CATALOG NO. _____
 MODEL REF. NO. _____ (FROM NAMEPLATE)
 PART NO. _____
 DESCRIPTION _____
 QUANTITY REQUIRED _____

FIG.	PART NO.	DESCRIPTION OF PART	NO. REQ.	FIG.	PART NO.	DESCRIPTION OF PART	NO. REQ.
1	23-58-0431	Wound Stator with Frame	(1)	17	40-50-7675	Finger Spring	(2)
2	23-40-0361	Rotor and Shaft Assembly	(1)	20	42-38-0106	Rubber Base Bumper	(4)
3	42-25-0261	End Shield	(2)	21	44-85-0141	L.H. Tool Rest	(1)
4	02-04-1720	Bearing	(2)	22	44-85-0151	R.H. Tool Rest	(1)
5	42-20-0135	Base	(1)	23	42-36-0025	Tool Rest Support	(2)
6	23-66-0100	On-Off Switch	(1)	24	06-10-0450	1/4-20x5/8 Carriage Bolt	(2)
7	23-66-0057	Rotary Switch	(1)	25	06-55-1500	1/4-20 Hex. Nut	(2)
8	23-66-0391	Stationary Switch	(1)	26	06-81-4650	10-32x3/8 Rd. Hd. Screw	(12)
9	-	Grinding Wheel (See Catalog)	(1)	27	22-64-0225	Cord with Plug	(1)
10	-	Grinding Wheel (See Catalog)	(1)	28	06-57-6060	10-32 Whiz Nut	(2)
12	43-54-0181	R.H. Wheel Guard	(1)	29	42-92-0115	Wheel Guard Cover	(2)
12A	43-54-0191	L.H. Wheel Guard	(1)	30	06-75-0066	10-32x8-1/2 Long thru Bolt	(2)
13	43-34-0027	Inner Wheel Flange	(2)	32	42-92-0045	Base Cover	(1)
14	43-34-0101	Outer Wheel Flange	(2)	33	45-12-0125	Spark Guard	(2)
15	06-55-3150	R.H. 1/2-20 Hex. Nut	(1)	34	06-10-1050	5/16-18x 1-1/8 Carriage Bolt	(4)
16	06-55-3175	L.H. 1/2-20 Hex. Nut	(1)	35	06-55-1985	5/16-18 Hex. Nut	(4)